

RG Series

High Rigidity Roller Type

2-9 RG Series – High Rigidity Roller Type Linear Guideway

2-9-1 Advantages and features

The new RG series from Hiwin features a roller as the rolling element instead of steel balls. The roller series offers super high rigidity and very high load capacities. The RG series is designed with a 45-degree angle of contact. Elastic deformation of the linear contact surface, during load, is greatly reduced thereby offering greater rigidity and higher load capacities in all 4 load directions. The RG series linear guideway offers high performance for high-precision manufacturing and achieving longer service life.

(1) Optimal design

FEM analysis was performed to determine the optimal structure of the block and the rail. The unique design of the circulation path allows the RG series linear guideway to offer smoother linear motion.

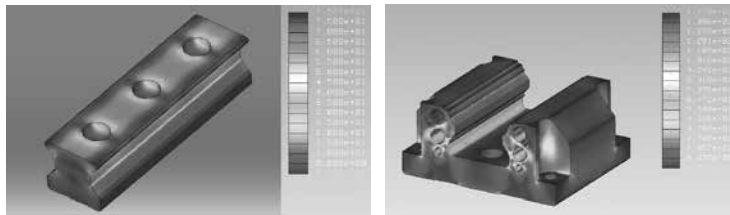

(2) Super high rigidity

The RG series is a type of linear guideway that uses rollers as the rolling elements. Rollers have a greater contact area than balls so that the roller guideway features higher load capacity and greater rigidity. The figure shows the rigidity of a roller and a ball with equal volume.

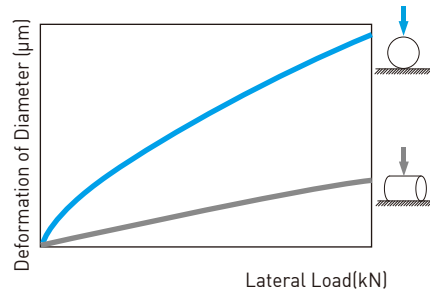

(3) Super high load capacity

With the four rows of rollers arranged at a contact angle of 45-degrees, the RG series linear guideway has equal load ratings in the radial, reverse radial and lateral directions. The RG series has a higher load capacity in a smaller size than conventional, ball-type linear guideways.

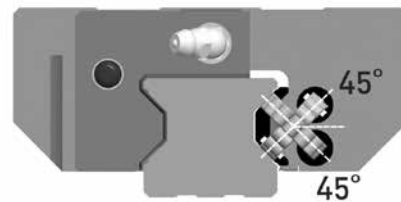

(4) Operating life increased

Compare with the ball element, the contact pressure of rolling element is distributed on the line region. Therefore, stress concentration was reduced significantly and the RG series offers longer running life. The nominal life of RG series can be calculated by using Eq.

The acting load will affect the nominal life of a linear guideway. Based on the selected basic dynamic rated load and the actual load. The nominal life of ball type and roller type linear guideway can be calculated by Eq.2.5 respectively.

$$L = \left(\frac{C}{P}\right)^{\frac{10}{3}} \cdot 100\text{km} = \left(\frac{C}{P}\right)^{\frac{10}{3}} \cdot 62\text{mile} \dots\dots\dots \text{Eq. 2.5}$$

If the environmental factors are taken into consideration, the nominal life is influenced greatly by the motion conditions, the hardness of the raceway, and the temperature of the linear guideway. The relationship between these factors is expressed in Eq.2.6.

$$L = \left(\frac{f_h \cdot f_t \cdot C}{f_w \cdot P}\right)^{\frac{10}{3}} \cdot 100\text{km} = \left(\frac{f_h \cdot f_t \cdot C}{f_w \cdot P}\right)^{\frac{10}{3}} \cdot 62\text{mile} \dots\dots\dots \text{Eq. 2.6}$$

- L : Nominal life
- C : Basic dynamic load rating
- P : Actual load
- f_h : Hardness factor
- f_t : Temperature factor
- f_w : Load factor

(5) Test Data
1. Nominal life test

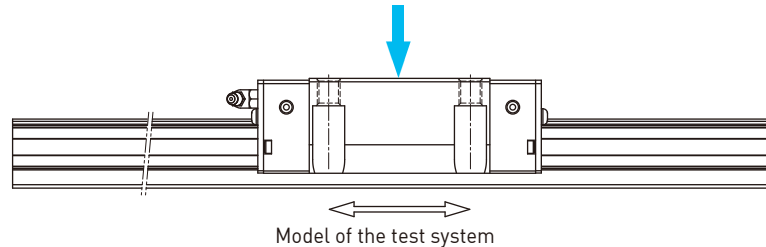



Table 2-9-1

<p>Tested model 1: RGH35CA Preload: ZA class Max. Speed: 60m/min Acceleration: 1G Stroke: 0.55m Lubrication: grease held every 100km External load: 15kN Traveling distance: 1135km</p>	<p>Test results: The nominal life of RGH35CA is 1000km. After traveling 1135km, fatigue flaking did not appear on the surface of the raceway or rollers.</p> 
---	---

2. Durability Test

<p>Tested model 2: RGW35CC Preload: ZA class Max. Speed: 120m/min Acceleration: 1G Stroke: 2m Lubrication: oil feed rate: 0.3cm³/hr External load: 0kN Traveling distance: 15000km</p>	<p>Test results: Fatigue flaking did not appear on the surface of the raceway or rollers after traveling 15000km.</p> 
---	--

Note: The data listed are from samples.

2-9-2 Construction of RG Series

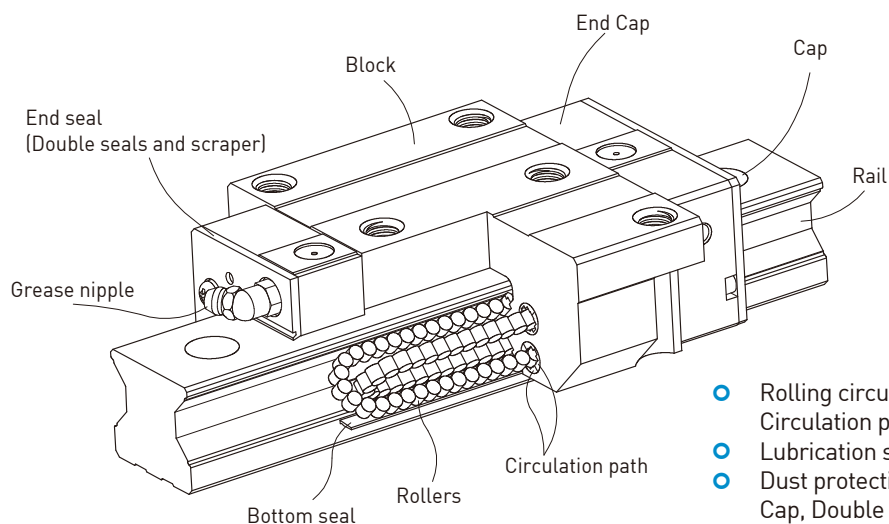

- Rolling circulation system: Block, Rail, End cap, Circulation path, rollers
- Lubrication system: Grease nipple and piping joint
- Dust protection system: End seal, Bottom seal, Cap, Double seals and Scraper

RG Series

High Rigidity Roller Type

2-9-3 Model Number of RG series

RG series linear guideways are classified into non-interchangeable and interchangeable types. The sizes of these two types are the same as one another. The main difference is that the interchangeable type of blocks and rails can be freely exchanged and they can maintain P-class accuracy. Because of strict dimensional control, the interchangeable type linear guideways are a wise choice for customers when rails do not need to be matched for an axis. The model number of the RG series identifies the size, type, accuracy class, preload class, etc.

(1) Non-interchangeable type

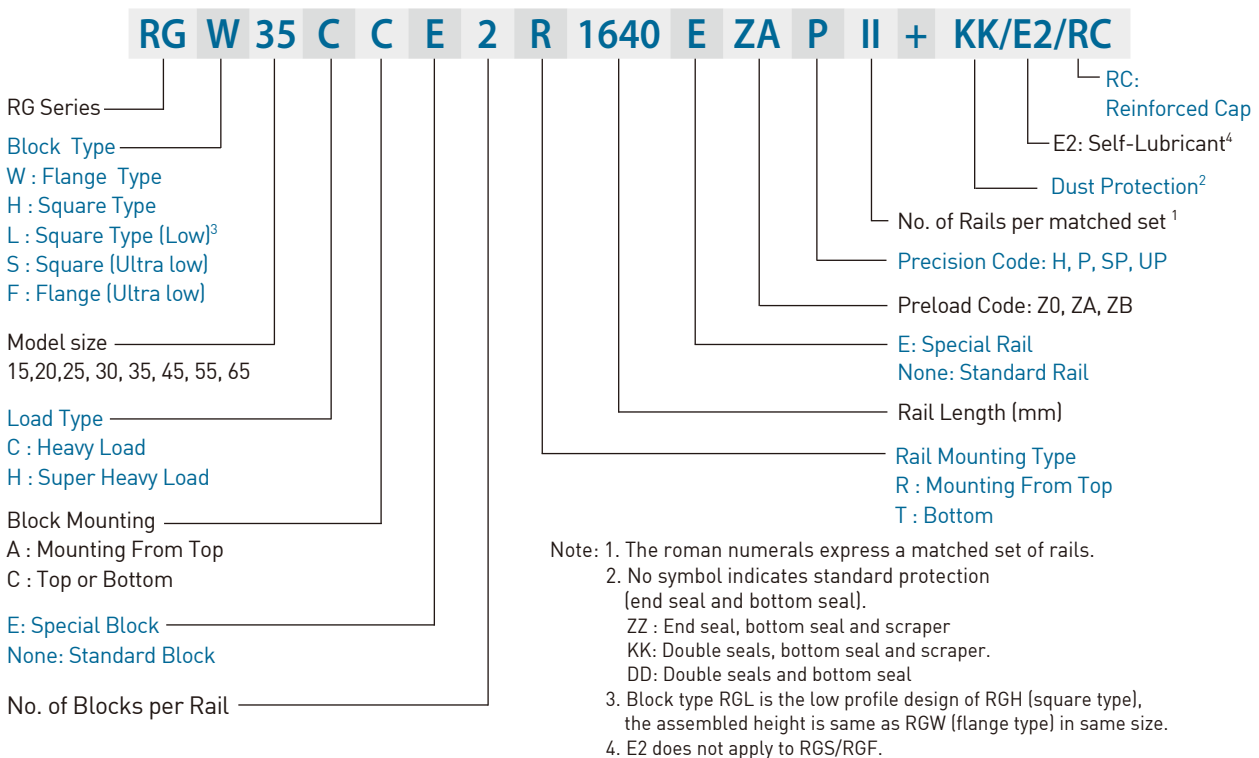

(2) Interchangeable type

Model Number of RG Block

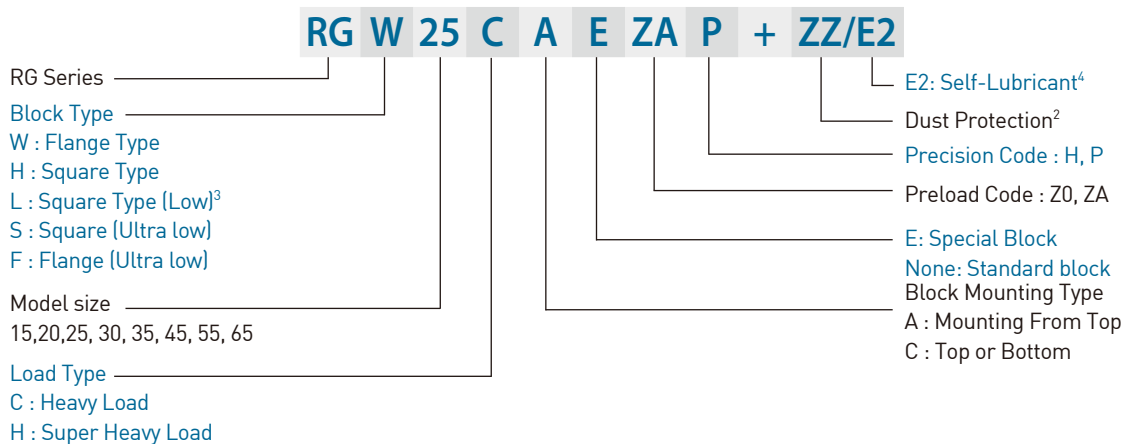

○ Model Number of RG Rail

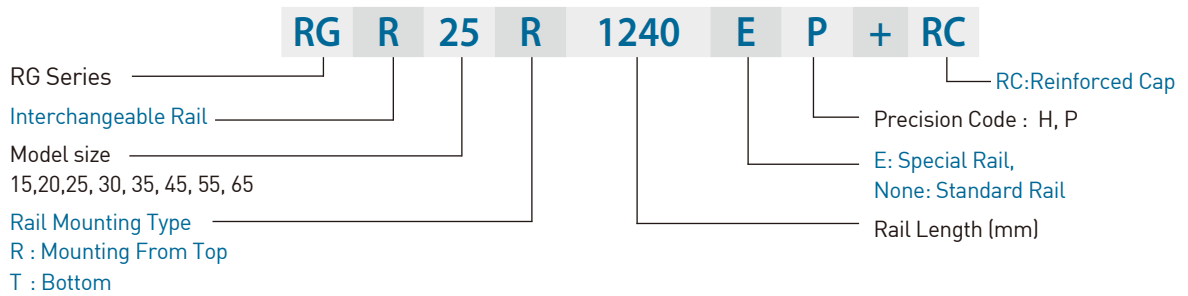

2-9-4 Types

(1) Block types

HIWIN offers two types of guide blocks, flange and square type. Because of the low assembly height and large mounting surface, the flange type is excellent for heavy moment load applications.

Table 2-9-2 Block Types

Type	Model	Shape	Height (mm)	Rail Length (mm)	Main Applications
Square	RGH-CA RGH-HA		28	100	<ul style="list-style-type: none"> ○ Automation Systems ○ Transportation equipment ○ CNC machining centers ○ Heavy duty cutting machines ○ CNC grinding machines ○ Injection molding machines ○ Plano millers ○ Devices requiring high rigidity ○ Devices requiring high load capacity ○ Electric discharge machines
			↓	↓	
Square (low)	RGL-CA RGL-HA		24	100	
			↓	↓	
Square (Ultra low)	RGS-CA RGS-HA		44	100	
			↓	↓	
Flange	RGW-CC RGW-HC		24	100	
			↓	↓	
Flange (Ultra low)	RGF-CC RGF-HC		90	4000	
			↓	↓	
Flange (Ultra low)	RGF-CC RGF-HC		44	100	
			↓	↓	
Flange (Ultra low)	RGF-CC RGF-HC		52	4000	
			↓	↓	

RG Series

High Rigidity Roller Type

(2) Rail types

In addition to the standard top mounting type, HIWIN also offers the bottom mounting type of rails.

Table 2-9-3 Rail Types

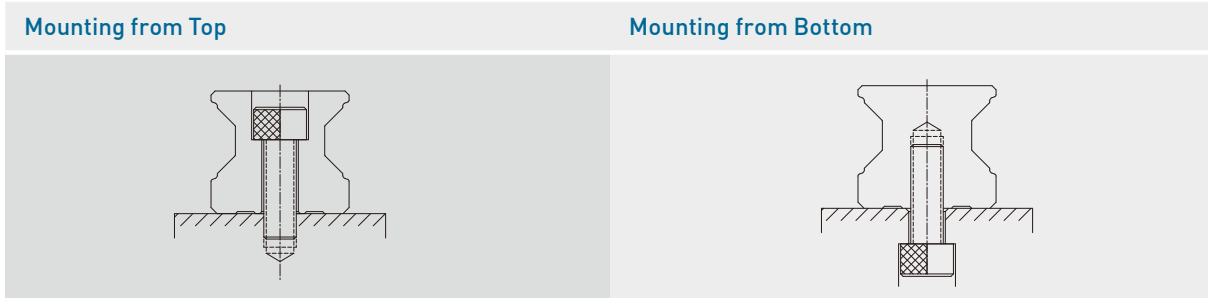

2-9-5 Accuracy Classes

The accuracy of the RG series can be classified into four classes: high (H), precision (P), super precision (SP) and ultra precision (UP). Customers may choose the class by referencing the accuracy requirements of the applied equipment.

(1) Accuracy of non-interchangeable

Table 2-9-4 Accuracy Standards

Item	RG - 15, 20			
	High (H)	Precision (P)	Super Precision (SP)	Ultra Precision (UP)
Dimensional tolerance of height H	± 0.03	0 - 0.03	0 - 0.015	0 - 0.008
Dimensional tolerance of width N	± 0.03	0 - 0.03	0 - 0.015	0 - 0.008
Variation of height H	0.01	0.006	0.004	0.003
Variation of width N	0.01	0.006	0.004	0.003
Running parallelism of block surface C to surface A	See Table 2-9-12			
Running parallelism of block surface D to surface B	See Table 2-9-12			

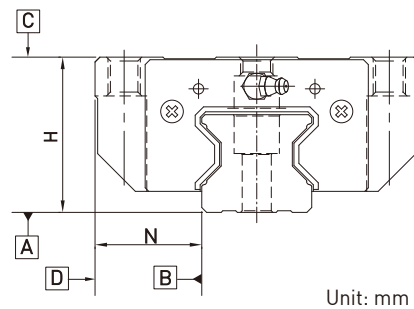

Table 2-9-5 Accuracy Standards

Unit: mm

Item	RG - 25, 30, 35			
	High (H)	Precision (P)	Super Precision (SP)	Ultra Precision (UP)
Dimensional tolerance of height H	± 0.04	0 - 0.04	0 - 0.02	0 - 0.01
Dimensional tolerance of width N	± 0.04	0 - 0.04	0 - 0.02	0 - 0.01
Variation of height H	0.015	0.007	0.005	0.003
Variation of width N	0.015	0.007	0.005	0.003
Running parallelism of block surface C to surface A	See Table 2-9-12			
Running parallelism of block surface D to surface B	See Table 2-9-12			

Table 2-9-6 Accuracy Standards

Unit: mm

Item	RG - 45, 55			
Accuracy Classes	High (H)	Precision (P)	Super Precision (SP)	Ultra Precision (UP)
Dimensional tolerance of height H	± 0.05	0 - 0.05	0 - 0.03	0 - 0.02
Dimensional tolerance of width N	± 0.05	0 - 0.05	0 - 0.03	0 - 0.02
Variation of height H	0.015	0.007	0.005	0.003
Variation of width N	0.02	0.01	0.007	0.005
Running parallelism of block surface C to surface A	See Table 2-9-12			
Running parallelism of block surface D to surface B	See Table 2-9-12			

Table 2-9-7 Accuracy Standards

Unit: mm

Item	RG - 65			
Accuracy Classes	High (H)	Precision (P)	Super Precision (SP)	Ultra Precision (UP)
Dimensional tolerance of height H	± 0.07	0 - 0.07	0 - 0.05	0 - 0.03
Dimensional tolerance of width N	± 0.07	0 - 0.07	0 - 0.05	0 - 0.03
Variation of height H	0.02	0.01	0.007	0.005
Variation of width N	0.025	0.015	0.01	0.007
Running parallelism of block surface C to surface A	See Table 2-9-12			
Running parallelism of block surface D to surface B	See Table 2-9-12			

(2) Accuracy of interchangeable

Table 2-9-8 Accuracy Standards

Unit: mm

Item	RG - 15, 20	
Accuracy Classes	High (H)	Precision (P)
Dimensional tolerance of height H	± 0.03	± 0.015
Dimensional tolerance of width N	± 0.03	± 0.015
Variation of height H	0.01	0.006
Variation of width N	0.01	0.006
Running parallelism of block surface C to surface A	See Table 2-9-12	
Running parallelism of block surface D to surface B	See Table 2-9-12	

Table 2-9-9 Accuracy Standards

Unit: mm

Item	RG - 25, 30, 35	
Accuracy Classes	High (H)	Precision (P)
Dimensional tolerance of height H	± 0.04	± 0.02
Dimensional tolerance of width N	± 0.04	± 0.02
Variation of height H	0.015	0.007
Variation of width N	0.015	0.007
Running parallelism of block surface C to surface A	See Table 2-9-12	
Running parallelism of block surface D to surface B	See Table 2-9-12	

RG Series

High Rigidity Roller Type

Table 2-9-10 Accuracy Standards

Unit: mm

Item	RG - 45, 55	
Accuracy Classes	High (H)	Precision (P)
Dimensional tolerance of height H	± 0.05	± 0.025
Dimensional tolerance of width N	± 0.05	± 0.025
Variation of height H	0.015	0.007
Variation of width N	0.02	0.01
Running parallelism of block surface C to surface A	See Table 2-9-12	
Running parallelism of block surface D to surface B	See Table 2-9-12	

Table 2-9-11 Accuracy Standards

Unit: mm

Item	RG - 65	
Accuracy Classes	High (H)	Precision (P)
Dimensional tolerance of height H	± 0.07	± 0.035
Dimensional tolerance of width N	± 0.07	± 0.035
Variation of height H	0.02	0.01
Variation of width N	0.025	0.015
Running parallelism of block surface C to surface A	See Table 2-9-12	
Running parallelism of block surface D to surface B	See Table 2-9-12	

(3) Accuracy of running parallelism

Table 2-9-12 Accuracy of Running Parallelism

Rail Length (mm)	Accuracy (μm)			
	H	P	SP	UP
~ 100	7	3	2	2
100 ~ 200	9	4	2	2
200 ~ 300	10	5	3	2
300 ~ 500	12	6	3	2
500 ~ 700	13	7	4	2
700 ~ 900	15	8	5	3
900 ~ 1,100	16	9	6	3
1,100 ~ 1,500	18	11	7	4
1,500 ~ 1,900	20	13	8	4
1,900 ~ 2,500	22	15	10	5
2,500 ~ 3,100	25	18	11	6
3,100 ~ 3,600	27	20	14	7
3,600 ~ 4,000	28	21	15	7

2-9-6 Preload

A preload can be applied to each guideway using oversized rollers. Generally, a linear motion guideway has negative clearance between the raceway and rollers to improve stiffness and maintain high precision. The RG series linear guideway offers three standard preloads for various applications and conditions.

Table 2-9-13

Class	Code	Preload	Condition
Light Preload	Z0	0.02C~0.04C	Certain load direction, low impact, low precision required
Medium Preload	ZA	0.07C~0.09C	High rigidity required, high precision required
Heavy Preload	ZB	0.12C~0.14C	Super high rigidity required, with vibration and impact

The figure shows the relationship between the rigidity, friction and nominal life. A preload no larger than ZA would be recommended for smaller model sizes to avoid over-preload affecting the life of the guideway.

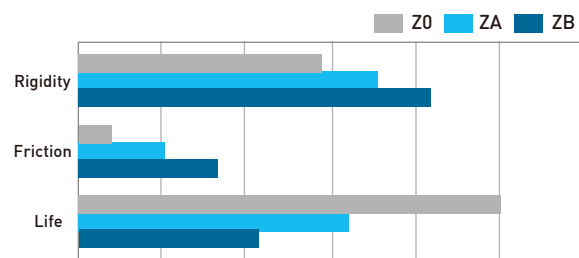

○ Stiffness performance

Stiffness depends on preload. The following table shows stiffness value of each size.

Table 2-9-14 Radial stiffness for RG Series

Load type	Series / Size	Stiffness (N/μm)		
		Z0	ZA	ZB
Heavy load	RG 15C	508	727	788
	RG 20C	625	853	950
	RG 25C	692	954	1196
	RG 30C	882	1082	1333
	RG 35C	1059	1247	1547
	RG 45C	1642	1851	2332
	RG 55C	1784	2053	2506
	RG 65C	2564	2900	3482
Super heavy load	RG 20H	840	1160	1279
	RG 25H	887	1242	1549
	RG 30H	1125	1391	1711
	RG 35H	1412	1757	2144
	RG 45H	2207	2511	3172
	RG 55H	2459	2858	3538
	RG 65H	3560	4064	4937

RG Series

High Rigidity Roller Type

2-9-7 Lubrication

(1) Grease

○ Grease nipple

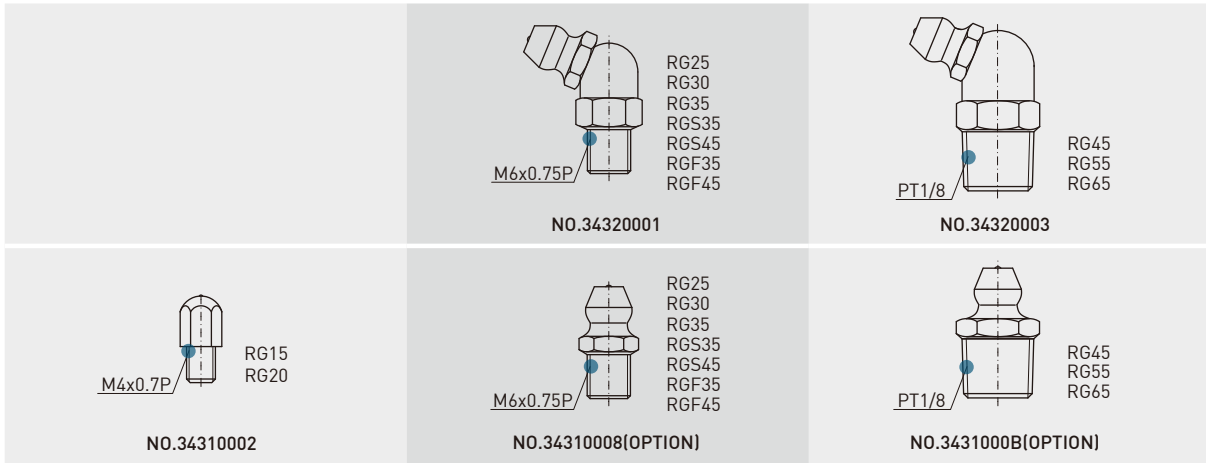

○ Mounting location

The standard location of the grease fitting is at both ends of the block, but the nipple can be mounted in the side or the top of block. For lateral installation, we recommend that the nipple be mounted at the non-reference side, otherwise please contact us. It is possible to carry out the lubrication by using an oil-piping joint. The figure shows the locations of the grease fitting.

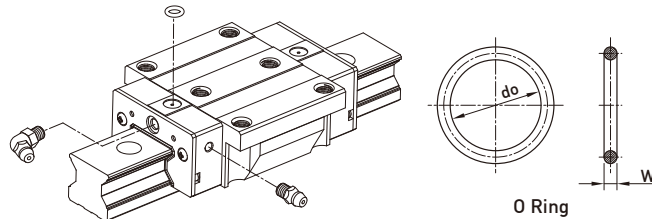

Table 2-9-15 O-Ring size and max. permissible depth for piercing

Size	O-Ring		Lube hole at top: max. permissible depth for piercing
	do (mm)	W (mm)	T _{max} (mm)
RG15	2.5±0.15	1.5±0.15	3.45
RG20	2.5±0.15	1.5±0.15	4
RG25	7.5±0.15	1.5±0.15	5.8
RG30	7.5±0.15	1.5±0.15	6.2
RG35	7.5±0.15	1.5±0.15	8.65
RG45	7.5±0.15	1.5±0.15	9.5
RG55	7.5±0.15	1.5±0.15	11.6
RG65	7.5±0.15	1.5±0.15	14.5

○ The oil amount for a block filled with grease

Table 2-9-16 The oil amount for a block filled with grease

Size	Heavy Load(cm ³)	Super Heavy Load(cm ³)	Size	Heavy Load(cm ³)	Super Heavy Load(cm ³)
RG15	3	-	RG35	12	14
RG20	5	6	RG45	19	23
RG25	7	8	RG55	28	35
RG30	9	10	RG65	52	63

○ Frequency of replenishment

Check the grease every 100 km, or every 3-6 months.

(2) Oil

The recommended viscosity of oil is about 32~150cSt. If you need to use oil-type lubrication, please inform us.

○ Types of oil piping joint

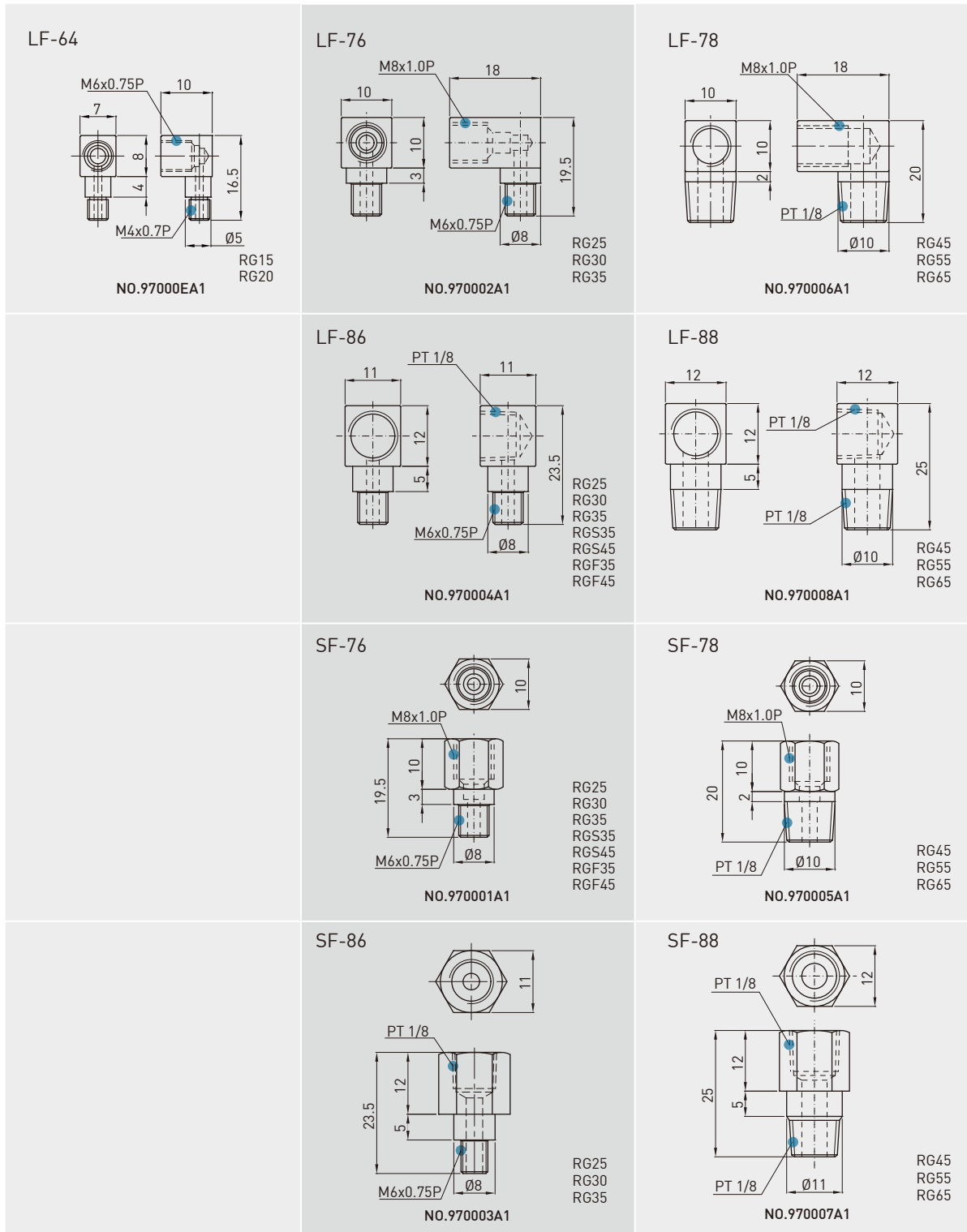

○ Oil feeding rate

Table 2-9-17 oil feed rate

Size	Feed rate (cm ³ /hr)	Size	Feed rate (cm ³ /hr)
RG15	0.14	RG35	0.23
RG20	0.14	RG45	0.3
RG25	0.167	RG55	0.367
RG30	0.2	RG65	0.433

RG Series

High Rigidity Roller Type

2-9-8 Dust Proof Accessories

(1) Codes of accessories

If the following accessories are needed, please add the code followed by the model number.

Table 2-9-18

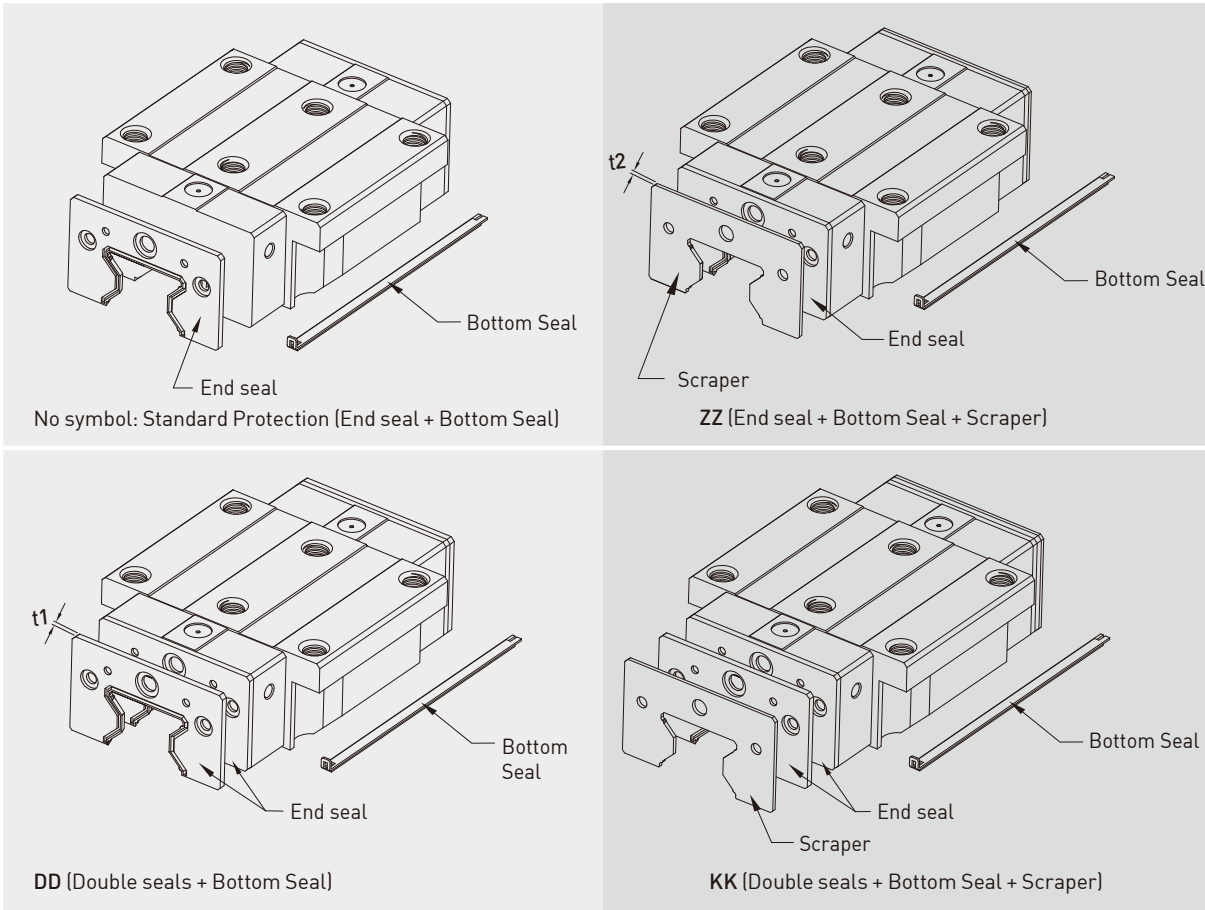

(2) End seal and bottom seal

To prevent life reduction caused by iron chips or dust entering the block.

(3) Double seals

Enhances the wiping effect, foreign matter can be completely wiped off.

Table 2-9-19 Dimensions of end seal

Size	Thickness (t1) (mm)	Size	Thickness (t1) (mm)
RG15 ES	2.2	RG35 ES	2.5
RG20 ES	2.2	RG45 ES	3.6
RG25 ES	2.2	RG55 ES	3.6
RG30 ES	2.4	RG65 ES	4.4

(4) Scraper

The scraper removes high-temperature iron chips and larger foreign objects.

Table 2-9-20 Dimensions of scraper

Size	Thickness (t2) (mm)	Size	Thickness (t2) (mm)
RG15 SC	1.0	RG35 SC	1.5
RG20 SC	1.0	RG45 SC	1.5
RG25 SC	1.0	RG55 SC	1.5
RG30 SC	1.5	RG65 SC	1.5

(5) Bolt caps for rail mounting holes

Caps are used to cover the mounting holes to prevent chips or other foreign objects from collecting in the holes. The caps will be enclosed in each rail package.

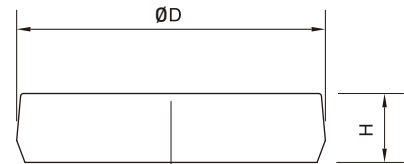
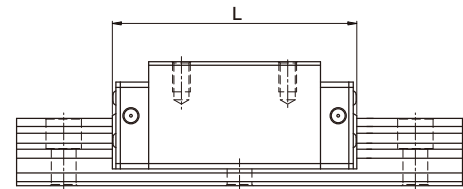

Table 2-9-21 Dimensions of Bolt Caps for Rail Mounting Holes

Rail size	Bolt size	Diameter(D) (mm)	Thickness(H) (mm)	Rail size	Bolt size	Diameter(D) (mm)	Thickness(H) (mm)
RGR15	M4	7.65	1.1	RGR35	M8	14.20	3.5
RGR20	M5	9.65	2.5	RGR45	M12	20.25	4.5
RGR25	M6	11.15	2.5	RGR55	M14	23.25	5
RGR30	M8	14.2	3.5	RGR65	M16	26.35	5

(6) Dimensions of block equipped with the dustproof parts



unit: mm

Table 2-9-22 Overall block length

Size	Overall block length (L)			
	SS	ZZ	DD	KK
RG15C	68.0 (70.4)	70.0 (74.4)	72.4 (74.8)	74.4 (78.8)
RG20C	86.0 (88.4)	88.0 (92.4)	90.4 (92.8)	92.4 (96.8)
RG20H	106.0 (108.4)	108.0 (112.4)	110.4 (112.8)	112.4 (116.8)
RG25C	97.9 (101.5)	99.9 (105.9)	102.3 (105.9)	104.3 (110.3)
RG25H	114.4 (118)	116.4 (122.4)	118.8 (122.4)	120.8 (126.8)
RG30C	109.8 (113.4)	112.8 (118.8)	114.6 (118.2)	117.6 (123.6)
RG30H	131.8 (135.4)	134.8 (140.8)	136.6 (140.2)	139.6 (145.6)
RG35C	124.0 (129.4)	127.0 (135.0)	129.0 (134.4)	132.0 (140.0)
RG35H	151.5 (156.9)	154.5 (162.5)	156.5 (161.9)	159.5 (167.5)
RG45C	153.2 (156.4)	156.2 (164.2)	160.4 (163.6)	163.4 (171.4)
RG45H	187.0 (190.2)	190.0 (198.0)	194.2 (197.4)	197.2 (205.2)
RG55C	183.7 (186.9)	186.7 (194.7)	190.9 (194.1)	193.9 (201.9)
RG55H	232.0 (235.2)	235.0 (243.0)	239.2 (242.4)	242.2 (250.2)
RG65C	232.0 (236.0)	235.0 (245.0)	240.8 (244.8)	243.8 (253.8)
RG65H	295.0 (299.0)	298.0 (308.0)	303.8 (307.8)	306.8 (316.8)

Note : The marking of “()” denotes the maximum block length with screws, lips of end seals, etc.

RG Series

High Rigidity Roller Type

2-9-9 Friction

The maximum value of resistance per end seal are as shown in the table.

Table 2-9-23 Seal Resistance

Size	Resistance N (kgf)	Size	Resistance N (kgf)
RG15	1.96 [0.2]	RG35	3.53 [0.36]
RG20	2.45 [0.25]	RG45	4.21 [0.43]
RG25	2.74 [0.28]	RG55	5.09 [0.52]
RG30	3.31 [0.31]	RG65	6.66 [0.68]

2-9-10 The Accuracy Tolerance of Mounting Surface

(1) The accuracy tolerance of rail-mounting surface

As long as the accuracy requirements of the mounting surfaces shown in the following tables are met, the high accuracy, high rigidity and long life of the RG series linear guideway will be maintained without any difficulty.

- The parallelism tolerance of reference surface (P)

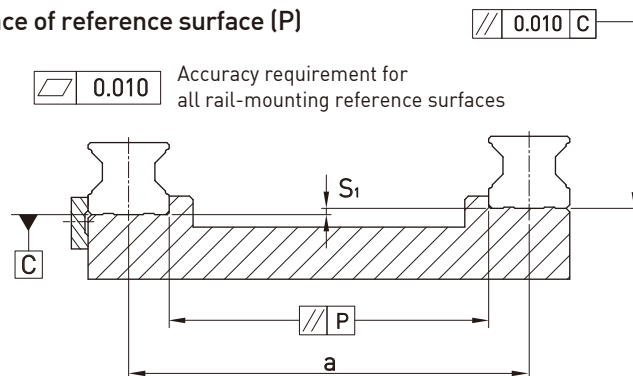

Table 2-9-24 Max. Parallelism Tolerance (P)

unit: μm

Size	Preload classes		
	Light Preload (Z0)	Medium Preload (ZA)	Heavy Preload (ZB)
RG15	5	3	3
RG20	8	6	4
RG25	9	7	5
RG30	11	8	6
RG35	14	10	7
RG45	17	13	9
RG55	21	14	11
RG65	27	18	14

- The accuracy tolerance of reference surface height (S_1)

$$S_1 = a \times K$$

S_1 : Max. tolerance of height

a : Distance between paired rails

K : Coefficient of tolerance of height

Table 2-9-25 Coefficient of tolerance of height

Size	Preload classes		
	Light Preload (Z0)	Medium Preload (ZA)	Heavy Preload (ZB)
K	2.2×10^{-4}	1.7×10^{-4}	1.2×10^{-4}

(2) The accuracy tolerance of block-mounting surface

- The tolerance of the height of reference surface when two or more pieces are used in parallel (S_2)

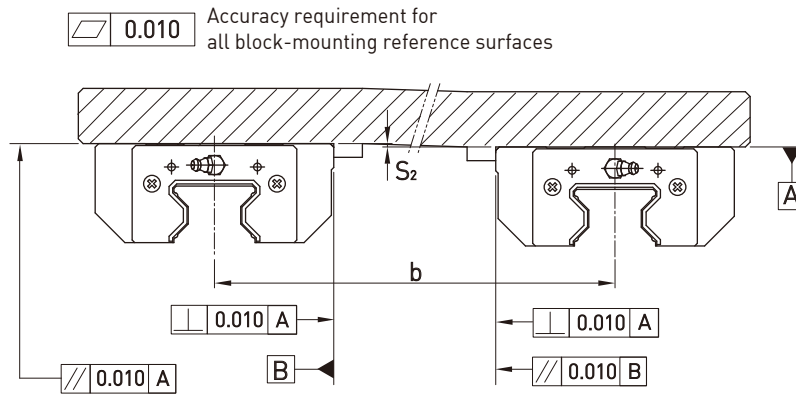

$$S_2 = b \times 4.2 \times 10^{-5}$$

S_2 : Max. tolerance of height

b : Distance between paired blocks

- The tolerance of the height of reference surface when two or more pieces are used in parallel (S_3)

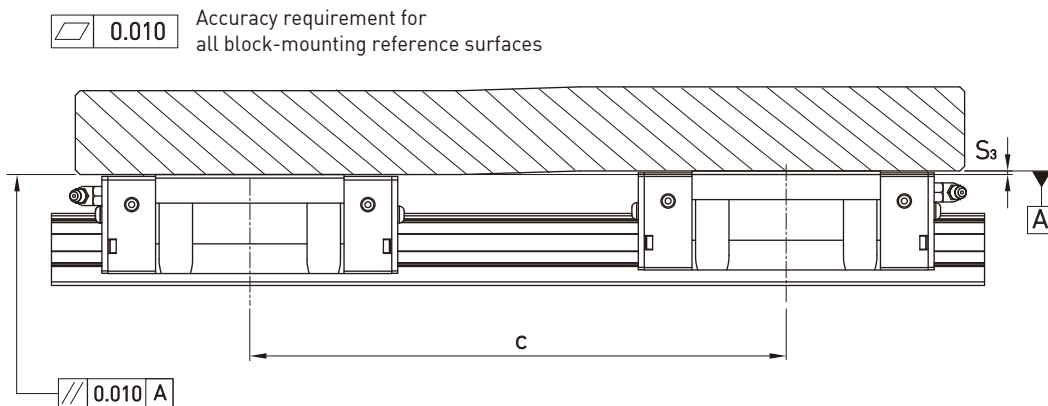

$$S_3 = c \times 4.2 \times 10^{-5}$$

S_3 : Max. tolerance of height

c : Distance between paired blocks

RG Series

High Rigidity Roller Type

2-9-11 Cautions for Installation

(1) Shoulder heights and fillets

Improper shoulder heights and fillets of mounting surfaces will cause a deviation in accuracy and interference with the chamfered part of the rail or block.

By following the recommended shoulder heights and fillets, accuracy problems in installation can be eliminated.

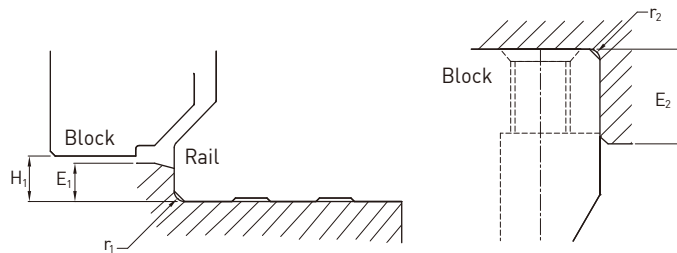

Table 2-9-26

Size	Max. radius of fillets r_1 (mm)	Max. radius of fillets r_2 (mm)	Shoulder height of the rail E_1 (mm)	Shoulder height of the block E_2 (mm)	Clearance under block H_1 (mm)
RG15	0.5	0.5	3	4	4
RG20	0.5	0.5	3.5	5	5
RG25	1.0	1.0	5	5	5.5
RG30	1.0	1.0	5	5	6
RG35	1.0	1.0	6	6	6.5
RG45	1.0	1.0	7	8	8
RG55	1.5	1.5	9	10	10
RG65	1.5	1.5	10	10	12

(2) Tightening Torque of Mounting Bolts

Improper tightening of mounting bolts will seriously influence the accuracy of a linear guideway. The following tightening torque for the different sizes of bolt is recommended.

Table 2-9-27

Size	Bolt size	Torque N-cm(kgf-cm)		
		Iron	Casting	Aluminum
RG15	M4×0.7P×16L	392 [40]	274 [28]	206 [21]
RG20	M5×0.8P×20L	883 [90]	588 [60]	441 [45]
RG25	M6×1P×20L	1373 [140]	921 [94]	686 [70]
RG30	M8×1.25P×25L	3041 [310]	2010 [205]	1470 [150]
RG35	M8×1.25P×25L	3041 [310]	2010 [205]	1470 [150]
RG45	M12×1.75P×35L	11772 [1200]	7840 [800]	5880 [600]
RG55	M14×2P×45L	15696 [1600]	10500 [1100]	7840 [800]
RG65	M16×2P×50L	19620 [2000]	13100 [1350]	9800 [1000]

2-9-12 Standard and Maximum Lengths of Rail

HIWIN offers a number of standard rail lengths. Standard rail lengths feature end mounting hole placements set to predetermined values (E). For non-standard rail lengths, be sure to specify the E-value to be no greater than 1/2 the pitch (P) dimension. An E-value greater than this will result in unstable rail ends.

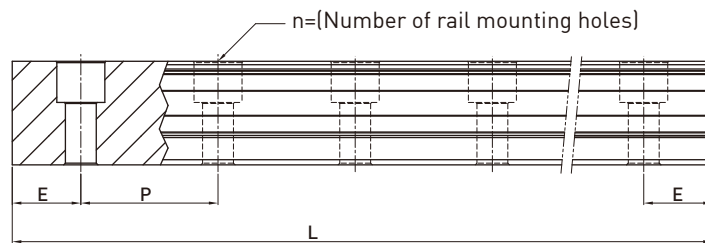

Table 2-9-28

unit: mm

Item	RGR15	RGR20	RGR25	RGR30	RGR35	RGR45	RGR55	RGR65
Standard Length L(n)	160 (5)	220 (7)	220 (7)	280 (7)	280 (7)	570 (11)	780 (13)	1,270 (17)
	220 (7)	280 (9)	280 (9)	440 (11)	440 (11)	885 (17)	1020 (17)	1,570 (21)
	340 (11)	340 (11)	340 (11)	600 (15)	600 (15)	1,200 (23)	1,260 (21)	2,020 (27)
	460 (15)	460 (15)	460 (15)	760 (19)	760 (19)	1,620 (31)	1,500 (25)	2,620 (35)
	580 (19)	640 (21)	640 (21)	1,000 (25)	1,000 (25)	2,040 (39)	1,980 (33)	-
	700 (23)	820 (27)	820 (27)	1,640 (41)	1,640 (41)	2,460 (47)	2,580 (43)	-
	940 (31)	1000 (33)	1,000 (33)	2,040 (51)	2,040 (51)	2,985 (57)	2,940 (49)	-
	1120 (37)	1180 (39)	1,240 (41)	2,520 (63)	2,520 (63)	3,090 (59)	3,060 (51)	-
	1360 (45)	1360 (45)	1,600 (53)	3,000 (75)	3,000 (75)	-	-	-
Pitch (P)	30	30	30	40	40	52.5	60	75
Distance to End (E _s)	20	20	20	20	20	22.5	30	35
Max. Standard Length	4,000 (133)	4,000 (133)	4,000 (133)	4,000 (100)	4,000 (100)	3,982.5 (76)	3,960 (66)	3,970 (53)
Max. Length	4,000	4,000	4,000	4,000	4,000	4,000	4,000	4,000

- Note :
1. Tolerance of E value for standard rail is 0.5~-0.5 mm. Tolerance of E value for jointed rail is 0~-0.3 mm.
 2. Maximum standard length means the max. rail length with standard E value on both sides.
 3. If different E value is needed, please contact HIWIN.

RG Series

High Rigidity Roller Type

2-9-13 Dimensions for RG series

(1) RGH-CA / RGH-HA

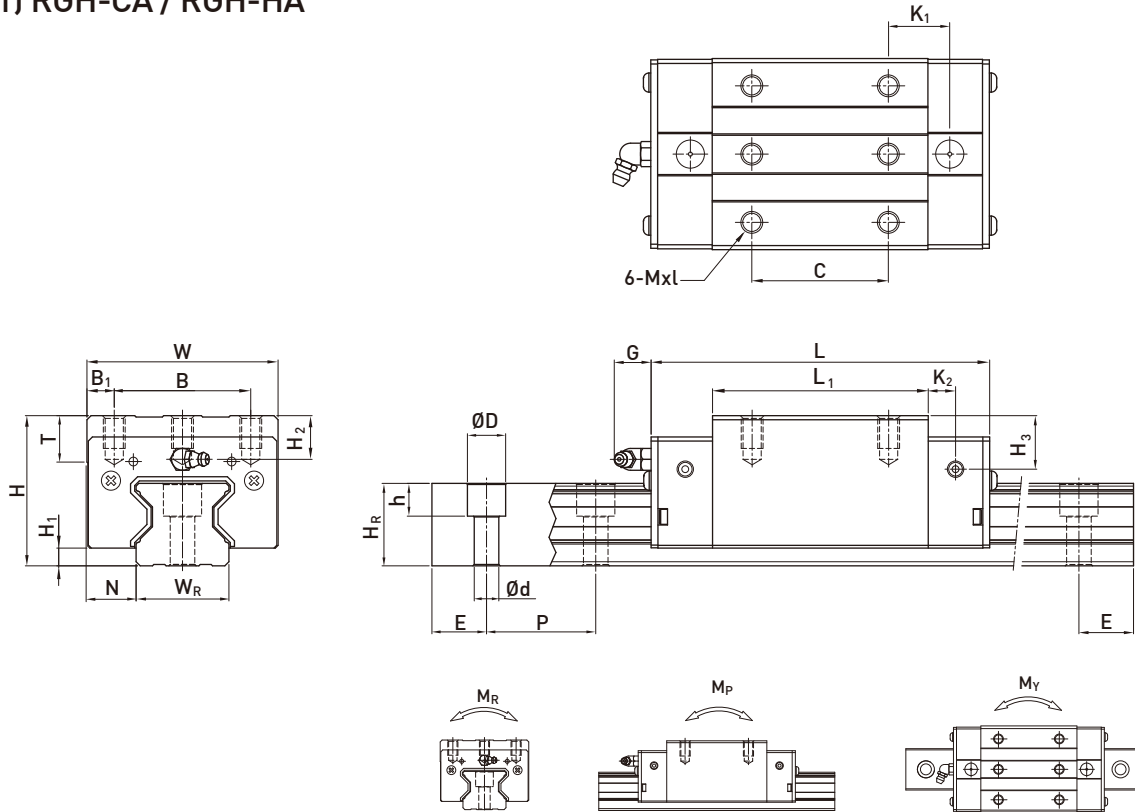

Model No.	Dimensions of Assembly (mm)			Dimensions of Block (mm)											Dimensions of Rail (mm)						Mounting Bolt for Rail (mm)	Basic Dynamic Load Rating C(kN)	Basic Static Load Rating C ₀ (kN)	Static Rated Moment			Weight				
	H	H ₁	N	W	B	B ₁	C	L ₁	L	K ₁	K ₂	G	Mxl	T	H ₂	H ₃	W _R	H _R	D	h				d	P	E	M _R	M _P	M _Y	Block kg	Rail kg/m
																								kN-m			kg				
RGH15CA	28	4	9.5	34	26	4	26	45	68	13.4	4.7	5.3	M4 x 8	6	7.6	10.1	15	16.5	7.5	5.7	4.5	30	20	M4 x16	11.3	24	0.311	0.173	0.173	0.20	1.8
RGH20CA	34	5	12	44	32	6	36	57.5	86	15.8	6	5.3	M5 x 8	8	8.3	8.3	20	21	9.5	8.5	6	30	20	M5 x20	21.3	46.7	0.647	0.46	0.46	0.40	2.76
RGH20HA							50	77.5	106	18.8															26.9	63	0.872	0.837	0.837	0.53	
RGH25CA	40	5.5	12.5	48	35	6.5	35	64.5	97.9	20.75	7.25	12	M6 x 8	9.5	10.2	10	23	23.6	11	9	7	30	20	M6 x20	27.7	57.1	0.758	0.605	0.605	0.61	3.08
RGH25HA							50	81	114.4	21.5															33.9	73.4	0.975	0.991	0.991	0.75	
RGH30CA	45	6	16	60	40	10	40	71	109.8	23.5	8	12	M8 x10	9.5	9.5	10.3	28	28	14	12	9	40	20	M8 x25	39.1	82.1	1.445	1.06	1.06	0.90	4.41
RGH30HA							60	93	131.8	24.5															48.1	105	1.846	1.712	1.712	1.16	
RGH35CA	55	6.5	18	70	50	10	50	79	124	22.5	10	12	M8 x12	12	16	19.6	34	30.2	14	12	9	40	20	M8 x25	57.9	105.2	2.17	1.44	1.44	1.57	6.06
RGH35HA							72	106.5	151.5	25.25															73.1	142	2.93	2.6	2.6	2.06	
RGH45CA	70	8	20.5	86	60	13	60	106	153.2	31	10	12.9	M10x17	16	20	24	45	38	20	17	14	52.5	22.5	M12 x35	92.6	178.8	4.52	3.05	3.05	3.18	9.97
RGH45HA							80	139.8	187	37.9															116	230.9	6.33	5.47	5.47	4.13	
RGH55CA	80	10	23.5	100	75	12.5	75	125.5	183.7	37.75	12.5	12.9	M12x18	17.5	22	27.5	53	44	23	20	16	60	30	M14 x45	130.5	252	8.01	5.4	5.4	4.89	13.98
RGH55HA							95	173.8	232	51.9															167.8	348	11.15	10.25	10.25	6.68	
RGH65CA	90	12	31.5	126	76	25	90	160	232	60.8	15.8	12.9	M16 x20	25	15	15	63	53	26	22	18	75	35	M16x50	213	411.6	16.20	11.59	11.59	8.89	20.22
RGH65HA							120	223	295	67.3															275.3	572.7	22.55	22.17	22.17	12.13	

Note : 1. 1 kgf = 9.81 N

2. The theoretical dynamic rated load is C_{100R}, if necessary C_{50R} conversion formula is as follows : C_{50R} = 1.23 x C_{100R}

(2) RGL-CA / RGL-HA

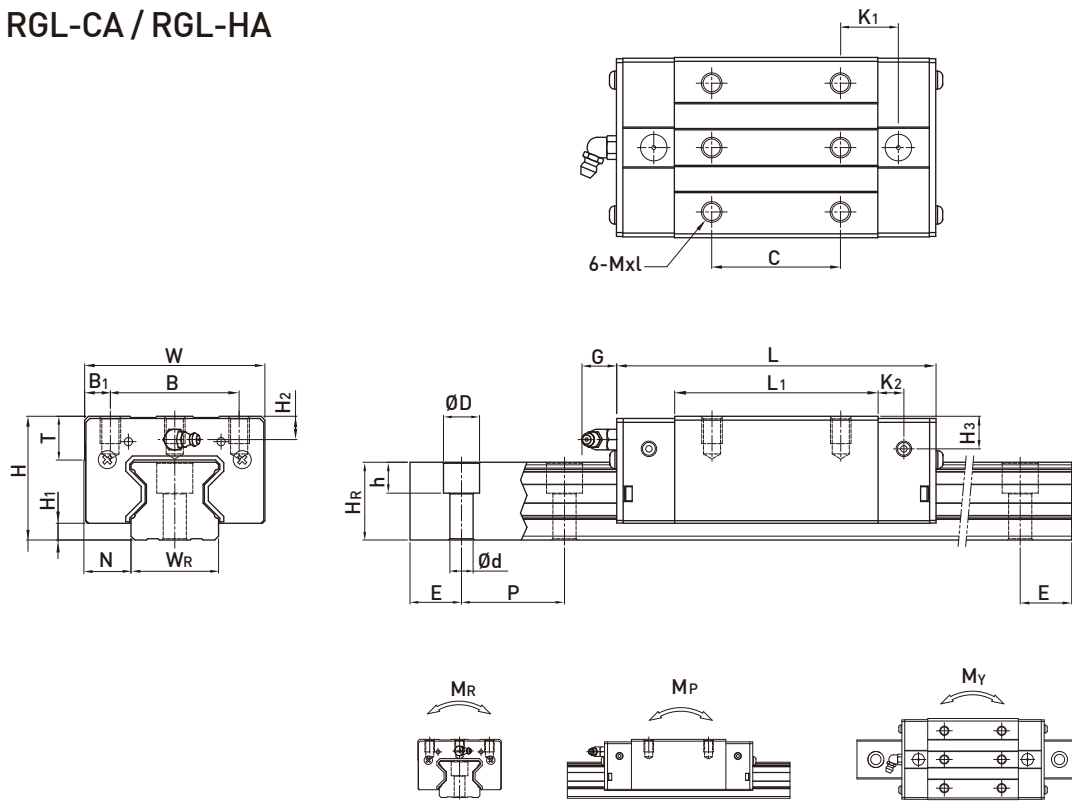

Model No.	Dimensions of Assembly (mm)			Dimensions of Block (mm)											Dimensions of Rail (mm)							Mounting Bolt for Rail (mm)	Basic Dynamic Load Rating C ₀ (kN)	Basic Static Load Rating C ₀ (kN)	Static Rated Moment			Weight			
	H	H ₁	N	W	B	B ₁	C	L ₁	L	K ₁	K ₂	G	Mxl	T	H ₂	H ₃	W _R	H _R	D	h	d				P	E	M _R	M _P	M _Y	Block kg	Rail kg/m
																									kN-m						
RGL15CA	24	4	9.5	34	26	4	26	45	68	13.4	4.7	5.3	M4X5.5	6	3.6	6.1	15	16.5	7.5	5.7	4.5	30	20	M4x16	11.3	24	0.311	0.173	0.173	0.15	1.8
RGL20CA	30	5	12	44	32	6	36	57.5	86	15.8	6	5.3	M5X6	8	4.3	4.3	20	21	9.5	8.5	6	30	20	M5x20	21.3	46.7	0.647	0.46	0.46	0.32	2.76
RGL20HA							50	77.5	106	18.8															26.9	63	0.872	0.837	0.837	0.42	
RGL25CA	36	5.5	12.5	48	35	6.5	35	64.5	97.9	20.75	7.25	12	M6x8	9.5	6.2	6	23	23.6	11	9	7	30	20	M6x20	27.7	57.1	0.758	0.605	0.605	0.51	3.08
RGL25HA							50	81	114.4	21.5															33.9	73.4	0.975	0.991	0.991	0.63	
RGL30CA	42	6	16	60	40	10	40	71	109.8	23.5	8	12	M8x10	9.5	6.5	7.3	28	28	14	12	9	40	20	M8x25	39.1	82.1	1.445	1.06	1.06	0.80	4.41
RGL30HA							60	93	131.8	24.5															48.1	105	1.846	1.712	1.712	1.03	
RGL35CA	48	6.5	18	70	50	10	50	79	124	22.5	10	12	M8x12	12	9	12.6	34	30.2	14	12	9	40	20	M8x25	57.9	105.2	2.17	1.44	1.44	1.27	6.06
RGL35HA							72	106.5	151.5	25.25															73.1	142	2.93	2.6	2.6	1.65	
RGL45CA	60	8	20.5	86	60	13	60	106	153.2	31	10	12.9	M10x17	16	10	14	45	38	20	17	14	52.5	22.5	M12x35	92.6	178.8	4.52	3.05	3.05	2.47	9.97
RGL45HA							80	139.8	187	37.9															116	230.9	6.33	5.47	5.47	3.20	
RGL55CA	70	10	23.5	100	75	12.5	75	125.5	183.7	37.75	12.5	12.9	M12x18	17.5	12	17.5	53	44	23	20	16	60	30	M14x45	130.5	252	8.01	5.4	5.4	3.91	13.98
RGL55HA							95	173.8	232	51.9															167.8	348	11.15	10.25	10.25	5.32	

Note : 1. 1 kgf = 9.81 N

2. The theoretical dynamic rated load is C_{100R}, if necessary C_{50R} conversion formula is as follows : C_{50R} = 1.23 x C_{100R}

RG Series

High Rigidity Roller Type

(3) RGW-CC / RGW-HC

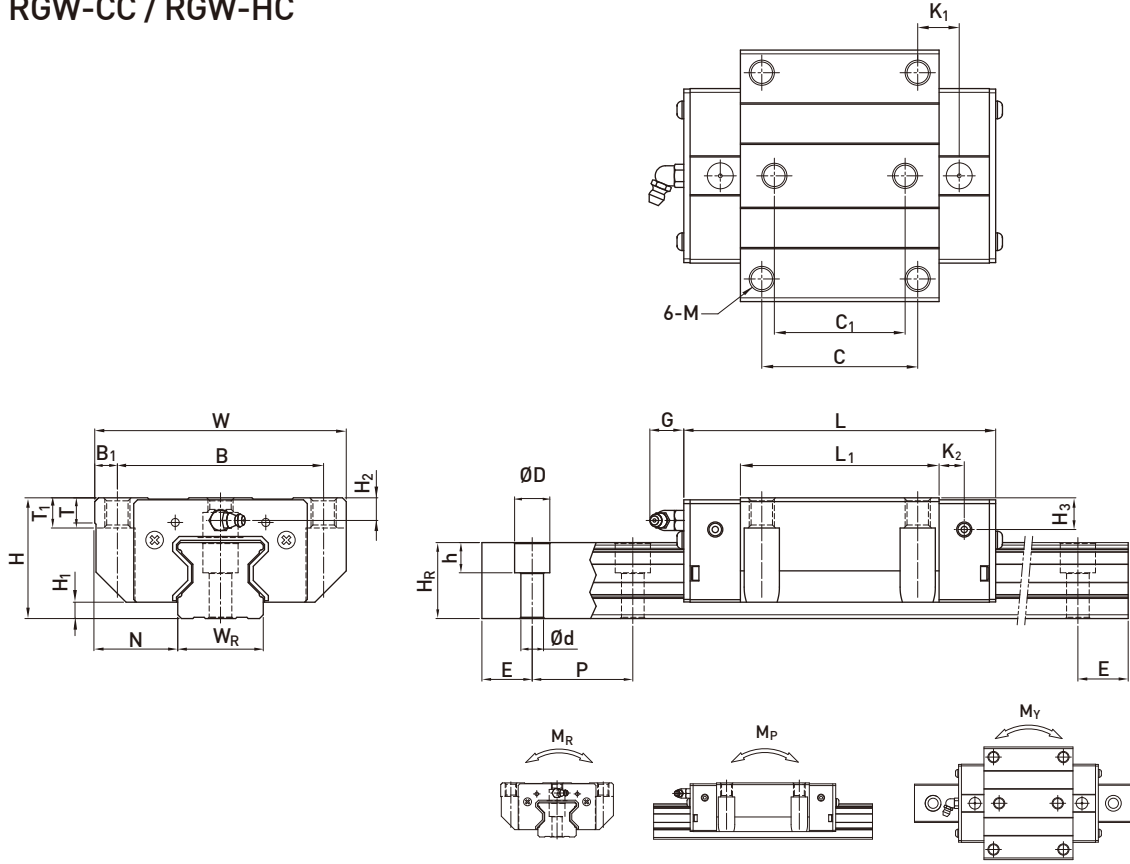

Model No.	Dimensions of Assembly (mm)		Dimensions of Block (mm)														Dimensions of Rail (mm)					Mounting Bolt for Rail (mm)	Basic Dynamic Load Rating C (kN)	Basic Static Load Rating C ₀ (kN)	Static Rated Moment			Weight					
	H	H ₁	N	W	B	B ₁	C	C ₁	L ₁	L	K ₁	K ₂	G	M	T	T ₁	H ₂	H ₃	W _R	H _R	D				h	d	P	E	M _R (kN-m)	M _P (kN-m)	M _Y (kN-m)	Block (kg)	Rail (kg/m)
RGW15CC	24	4	16	47	38	4.5	30	26	45	68	11.4	4.7	5.3	M5	6	6.95	3.6	6.1	15	16.5	7.5	5.7	4.5	30	20	M4x16	11.3	24	0.311	0.173	0.173	0.22	1.8
RGW20CC	30	5	21.5	63	53	5	40	35	57.5	86	13.8	6	5.3	M6	8	10	4.3	4.3	20	21	9.5	8.5	6	30	20	M5x20	21.3	46.7	0.647	0.46	0.46	0.47	2.76
RGW20HC									77.5	106	23.8																26.9	63	0.872	0.837	0.837	0.63	
RGW25CC	36	5.5	23.5	70	57	6.5	45	40	64.5	97.9	15.75	7.25	12	M8	9.5	10	6.2	6	23	23.6	11	9	7	30	20	M6x20	27.7	57.1	0.758	0.605	0.605	0.72	3.08
RGW25HC									81	114.4	24																33.9	73.4	0.975	0.991	0.991	0.91	
RGW30CC	42	6	31	90	72	9	52	44	71	109.8	17.5	8	12	M10	9.5	10	6.5	7.3	28	28	14	12	9	40	20	M8x25	39.1	82.1	1.445	1.06	1.06	1.16	4.41
RGW30HC									93	131.8	28.5																48.1	105	1.846	1.712	1.712	1.52	
RGW35CC	48	6.5	33	100	82	9	62	52	79	124	16.5	10	12	M10	12	13	9	12.6	34	30.2	14	12	9	40	20	M8x25	57.9	105.2	2.17	1.44	1.44	1.75	6.06
RGW35HC									106.5	151.5	30.25																73.1	142	2.93	2.6	2.6	2.40	
RGW45CC	60	8	37.5	120	100	10	80	60	106	153.2	21	10	12.9	M12	14	15	10	14	45	38	20	17	14	52.5	22.5	M12x35	92.6	178.8	4.52	3.05	3.05	3.43	9.97
RGW45HC									139.8	187	37.9																116	230.9	6.33	5.47	5.47	4.57	
RGW55CC	70	10	43.5	140	116	12	95	70	125.5	183.7	27.75	12.5	12.9	M14	16	17	12	17.5	53	44	23	20	16	60	30	M14x45	130.5	252	8.01	5.4	5.4	5.43	13.98
RGW55HC									173.8	232	51.9																167.8	348	11.15	10.25	10.25	7.61	
RGW 65CC	90	12	53.5	170	142	14	110	82	160	232	40.8	15.8	12.9	M16	22	23	15	15	63	53	26	22	18	75	35	M16x50	213	411.6	16.20	11.59	11.59	11.63	20.22
RGW 65HC									223	295	72.3																275.3	572.7	22.55	22.17	22.17	16.58	

Note : 1. 1 kgf = 9.81 N

2. The theoretical dynamic rated load is C_{100R}, if necessary C_{50R} conversion formula is as follows : C_{50R} = 1.23 x C_{100R}

(4) RGS-CA/RGS-HA

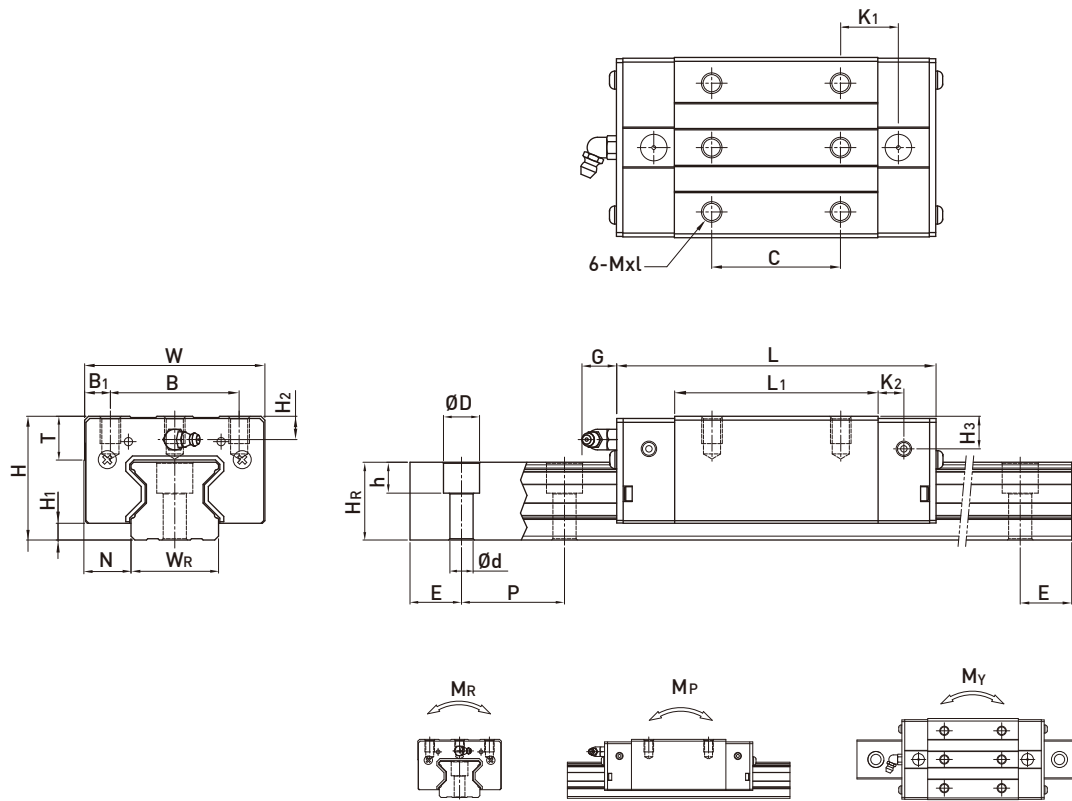

Model No.	Dimensions of Assembly (mm)		Dimensions of Block (mm)													Dimensions of Rail (mm)					Mounting Bolt for Rail (mm)	Basic Dynamic Load Rating C (kN)	Basic Static Load Rating C ₀ (kN)	Static Rated Moment			Weight				
	H	H ₁	N	W	B	B ₁	C	L ₁	L	K ₁	K ₂	G	Mxl	T	H ₂	H ₃	W _R	H _R	D	h				d	P	E	M _R	M _P	M _Y	Block	Rail
	mm	mm	mm	mm	mm	mm	mm	mm	mm	mm	mm	mm	mm	mm	mm	mm	mm	mm	mm	mm				mm	mm	mm	mm	kN-m	kN-m	kN-m	kg
RGS35CA	44	6.5	18	70	50	10	50	79	124	22.5	10	12	M8x9	12	6.5	7.8	34	30.2	14	12	9	40	20	M8x25	57.9	105.2	2.17	1.44	1.44	1.12	6.06
RGS35HA							72	106.5	151.5	25.25														M8x25	73.1	142	2.93	2.6	2.6	1.45	
RGS45CA	52	8	20.5	86	60	13	60	106	153.2	31	10	12.9	M10x11	16	7	7	45	38	20	17	14	52.5	22.5	M12x35	92.6	178.8	4.52	3.05	3.05	1.96	9.97
RGS45HA							80	139.8	187	37.9														M12x35	116	230.9	6.33	5.47	5.47	2.5	

Note : 1. 1 kgf = 9.81 N

2. The theoretical dynamic rated load is C_{100R}, if necessary C_{50R} conversion formula is as follows : C_{50R} = 1.23 x C_{100R}

(6) Dimensions for RGR-T (Rail Mounting from Bottom)

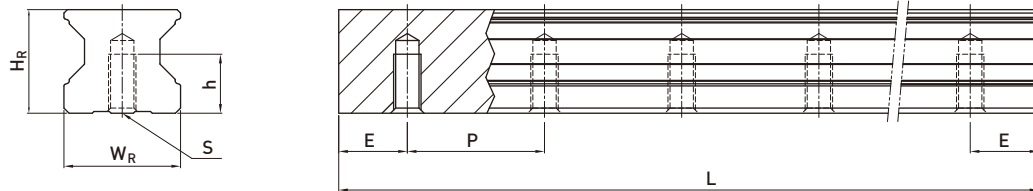

Model No.	Dimensions of Rail (mm)						Weight
	W_R	H_R	S	h	P	E	(kg/m)
RGR15T	15	16.5	M5×0.8P	8	30	20	1.86
RGR20T	20	21	M6×1P	10	30	20	2.76
RGR25T	23	23.6	M6×1P	12	30	20	3.36
RGR30T	28	28	M8×1.25P	15	40	20	4.82
RGR35T	34	30.2	M8×1.25P	17	40	20	6.48
RGR45T	45	38	M12×1.75P	24	52.5	22.5	10.83
RGR55T	53	44	M14×2P	24	60	30	15.15
RGR65T	63	53	M20×2.5P	30	75	35	21.24