

Position measuring module (Continued from last page, P.206)

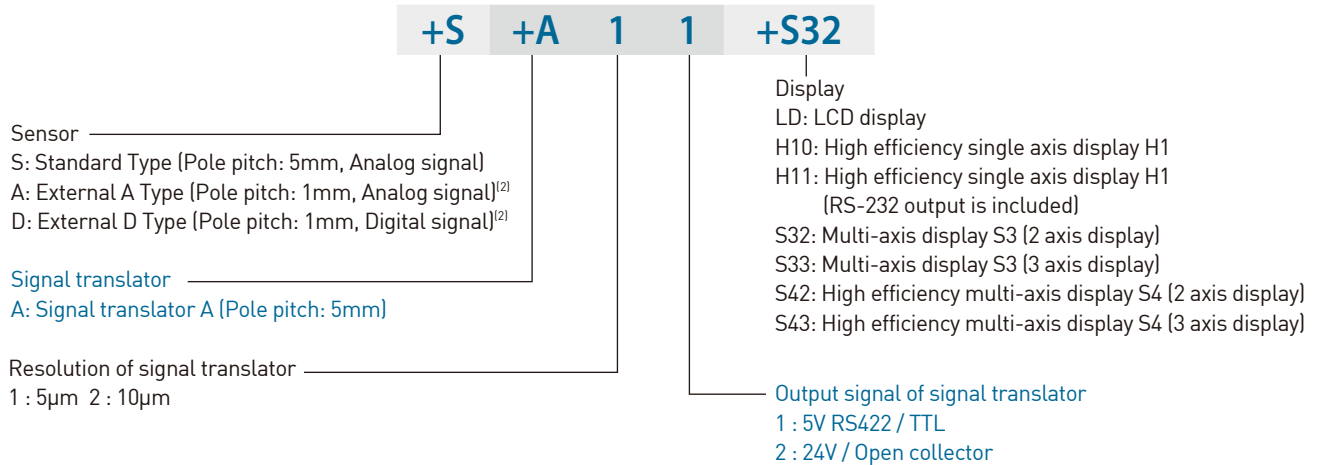

Note: (1) If rail mounting configuration is from bottom, magnetic strip will be affixed on the rail.
 (2) External type sensors (A and D) are only available for size 20 and 25.

Table 2-13-1 The help of selecting the components for the position measuring module.

Sensor	Signal translator	Resolution of signal translator	Output signal of signal translator	Display
S: Standard Type (Pole pitch: 5mm, Analog signal)	A: Signal translator A (Pole pitch: 5mm)	1:5µm 2:10µm	1:5V RS422/TTL 2:24V/Open collector	S32: Multi-axis display S3 (2 axis display)
				S33: Multi-axis display S3 (3 axis display)
				S42: High efficiency multi-axis display S4 (2 axis display)
				S43: High efficiency multi-axis display S4 (3 axis display)
	Does not need a signal translator	LD: LCD display		
		H10: High efficiency single axis display H1 H11: High efficiency single axis display H1 (RS-232 output is included)		
A: External A Type (Pole pitch: 1mm, Analog signal) (Only available for size 20 and 25)	Does not need a signal translator	H10: High efficiency single axis display H1		
		H11: High efficiency single axis display H1 (RS-232 output is included)		
D: External D Type (Pole pitch: 1mm, Digital signal) (Only available for size 20 and 25)	Does not need a signal translator	H10: High efficiency single axis display H1		
		H11: High efficiency single axis display H1 (RS-232 output is included)		
		S32: Multi-axis display S3 (2 axis display)		
		S33: Multi-axis display S3 (3 axis display)		
		S42: High efficiency multi-axis display S4 (2 axis display)		
		S43: High efficiency multi-axis display S4 (3 axis display)		

PG Type

Positioning Guideway

2-13-2 Technical data for PG Type

(1) Sensor technical data

Table 2-13-2 Technical data for the sensor

Type	Specification		
	Standard	External	
		A type (analog signal)	D type (digital signal)
Resolution	5mm	1mm	1mm
Repeatability	$\pm 10 \mu\text{m}^{(1)}$	$\pm 3 \mu\text{m}^{(2)}$	$\pm 2 \mu\text{m}^{(2)}$
Reference signal	-	1mm/pulse	1mm/pulse
Max. speed	10m/sec	10m/sec	5m/sec
Output signal	SIN/COS 50mVp-p	SIN/COS 1Vp-p	5V RS422/TTL
Max. output frequency	2KHz	10KHz	1.25MHz
Input power	3.3VDC $\pm 5\%$	5VDC $\pm 5\%$	5VDC $\pm 5\%$
Input current	0.1A	0.1A	0.1A
Operating temperature	0°C~50°C	0°C~50°C	0°C~50°C
Storage temperature	-5°C~70°C	-5°C~70°C	-5°C~70°C
IP class	IP67	IP67	IP67

Note : (1) Repeatability is measured at a gap of 1mm.
(2) Repeatability is measured at a gap of 0.1mm.

○ Dimensions for the external type sensor

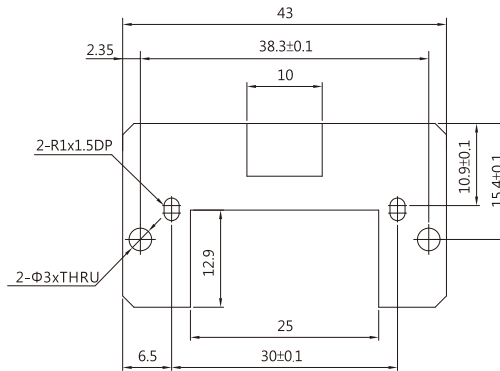
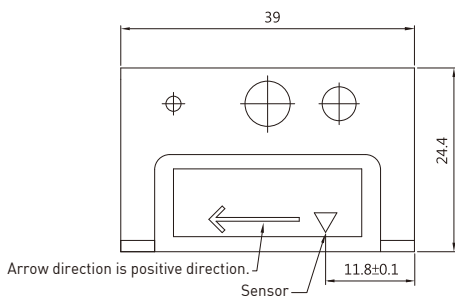

Note: These dimensions are suitable for HIWIN PGH20 linear guideway.

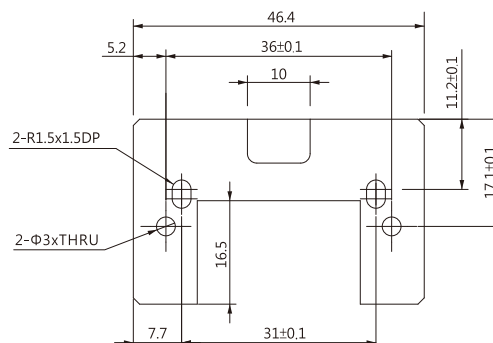
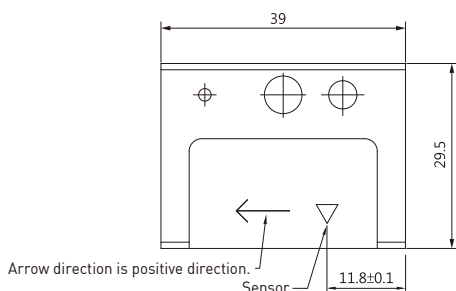

Note: These dimensions are suitable for HIWIN PGH25 linear guideway.

(2) Signal translator technical data

Table 2-13-3 Technical data for the signal translator

Type				
Specification	Signal translator A			
Output signal	5V RS422 / TTL		24V/Open collector	
Resolution	5 μm	10 μm	5 μm	10 μm
Repeatability	±10 μm	±20 μm	±10 μm	±20 μm
Max. output frequency	64KHz	32KHz	64KHz	32KHz
Accuracy	±[80 μm+15 μm/m×L] , L: Scale Length (m)			
Max. speed	1.5m/sec			
Input signal	SIN/COS 50mVp-p			
Input power	5VDC±5% / 24VDC±10%			
Input current	0.5A			
Operating temperature	0°C ~ 50°C			
Storage temperature	-5°C ~ 70°C			
IP class	IP43			

○ Dimensions of signal translator A

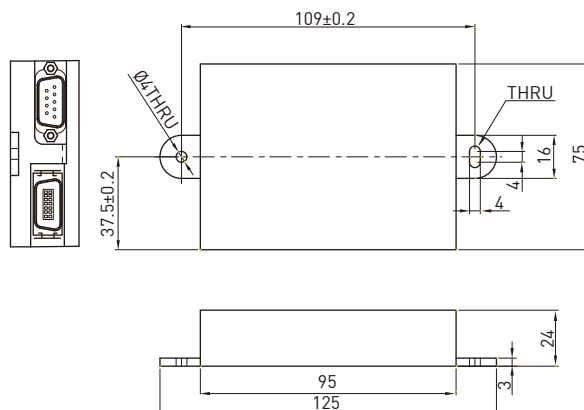

PG Type Positioning Guideway

(3) Display technical data

Table 2-13-4 Technical data for the single axis display





Type		
Specification	LCD display, LD	High efficiency single axis display, H1
Display	8 digital LCD display with +/- sign	8 digital LED display
Resolution	5μm	1μm, 2μm, 5μm, 10μm
Accuracy	±[80μm+15μm/m×L] L: Scale Length (m)	-
Repeatability	±10μm	-
Max. speed	3m/sec	-
Max. acceleration	2G	2G
Input signal	Analog:SIN/COS 50mVp-p	Analog:SIN/COS 1Vp-p Digital:5V RS422/TTL
Input frequency	0.6KHz	Analog:2KHz Digital:0.5MHz
Input power	Two commercial AA No.3 batteries	5VDC±5%
Input current	-	1A
Relay contact rating	-	DC24V/2A
Battery life	1 year by setting it at 1.5m/s	-
Operating temperature	0°C ~ 50°C	0°C ~ 50°C
Storage temperature	-5°C ~ 70°C	-5°C ~ 70°C
IP class	IP43	IP43

Table 2-13-5 Technical data for the multi-axis display

Type		
Specification	Multi-axis display, S3	High efficiency multi-axis display, S4
Display	8 digital LED display	8 digital LED display
Resolution	0.1μm, 0.2μm, 0.5μm, 1μm, 2μm, 5μm, 10μm, 20μm, 50μm	0.1μm, 0.2μm, 0.5μm, 1μm, 2μm, 5μm, 10μm, 20μm, 50μm
Input signal	5V/TTL	5V/TTL
Max. output frequency	<1.5MHz	<2MHz
Input power	DC 8V~30V	AC 90V~240V
Input current	0.08A	-
Operating temperature	0°C~50°C	0°C~50°C
Storage temperature	-5°C~70°C	-5°C~70°C
IP class	IP43	IP43

Note: An additional signal transfer cable is needed when one of the displays (H1, S3, S4) is selected. The type of cable will be selected by HIWIN depending on the type of display.

○ Dimensions of LCD display, LD

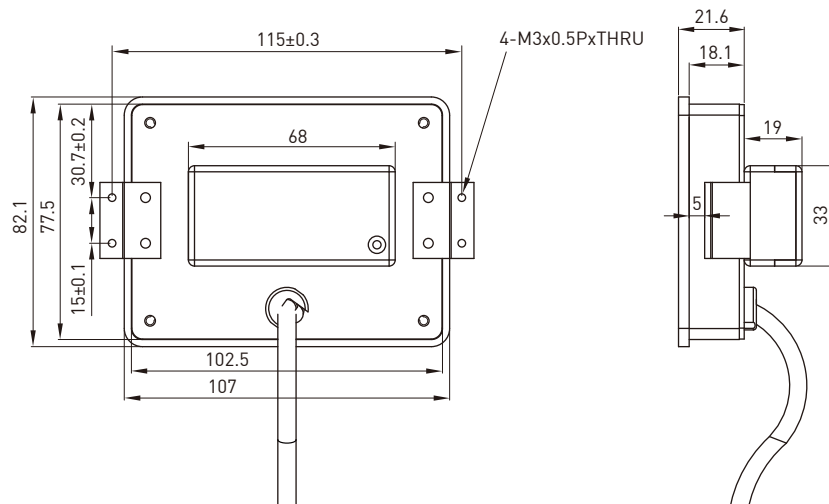

○ Dimensions of high efficiency single axis display, H1

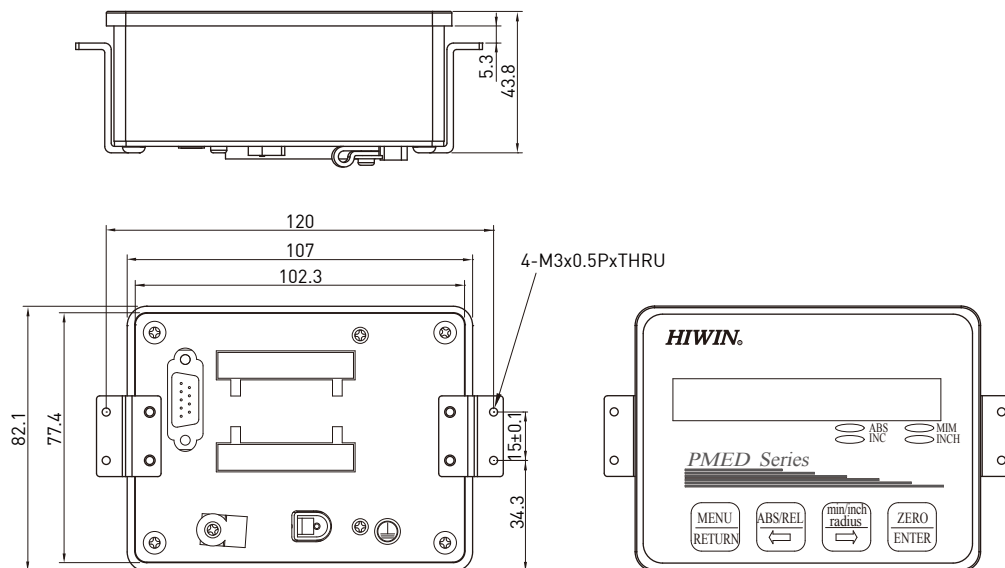

PG Type

Positioning Guideway

- Pin assignment of high efficiency single axis display, H1

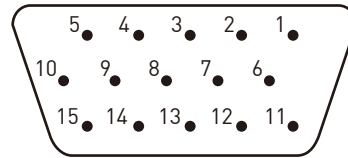

Pin definition for signal input connector

Pin	Designation	Pin	Designation	Pin	Designation
1	+5V	6	FG	11	A+(Analog)
2	GND	7	Z+	12	A-(Analog)
3	A+(Digital)	8	Z-	13	B+(Analog)
4	B+(Digital)	9	A-(Digital)	14	B-(Analog)
5	NC	10	B-(Digital)	15	NC

Pin definition for signal output connector

I/O 1		I/O 2	
Pin	Designation	Pin	Designation
1	NC	1	NC
2	NC	2	NC
3	NC	3	NC
4	NC	4	NC
5	Relay 0(CH-0)	5	Relay 2(CH-2)
6	Relay 1(CH-1)	6	Relay 3(CH-3)
7	Relay 0(CH-0)	7	Relay 2(CH-2)
8	Relay 1(CH-1)	8	Relay 3(CH-3)

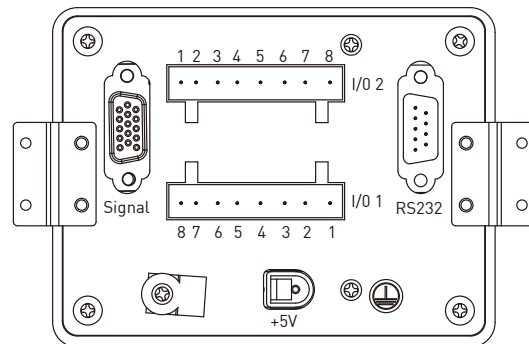

- Dimensions of multi-axis display, S3

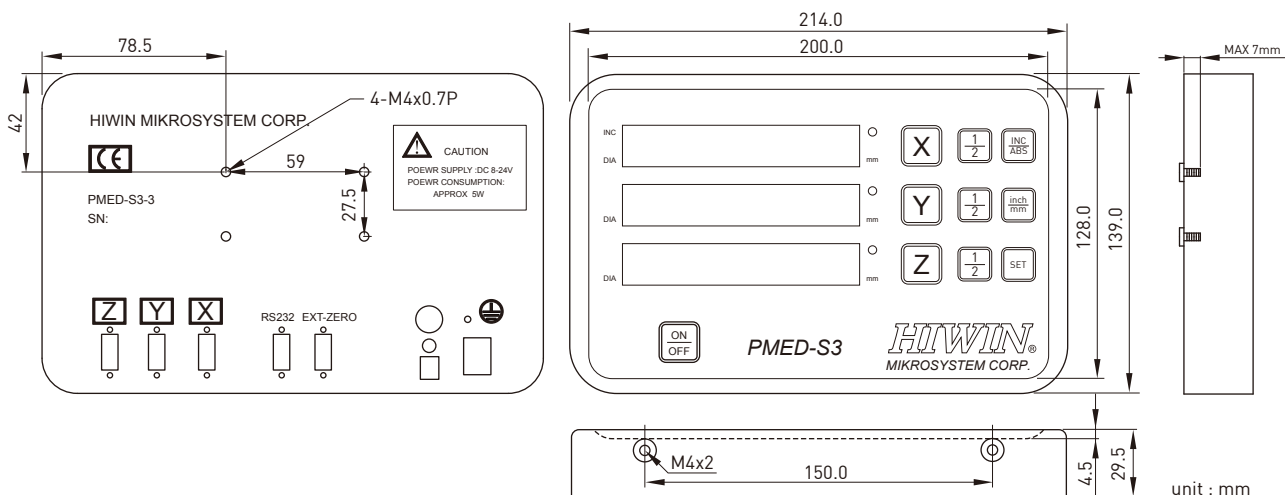

○ Pin assignment of multi-axis display, S3

15 pin D-Sub signal
(female)

NC : No connection
FG : Frame ground

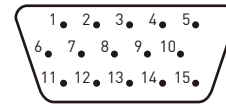

Pin	Designation	Pin	Designation	Pin	Designation
1	+5V	6	FG	11	NC
2	GND	7	NC	12	NC
3	A+	8	NC	13	NC
4	B+	9	NC	14	NC
5	ABS-	10	NC	15	NC

○ Dimensions of high efficiency multi-axis display, S4

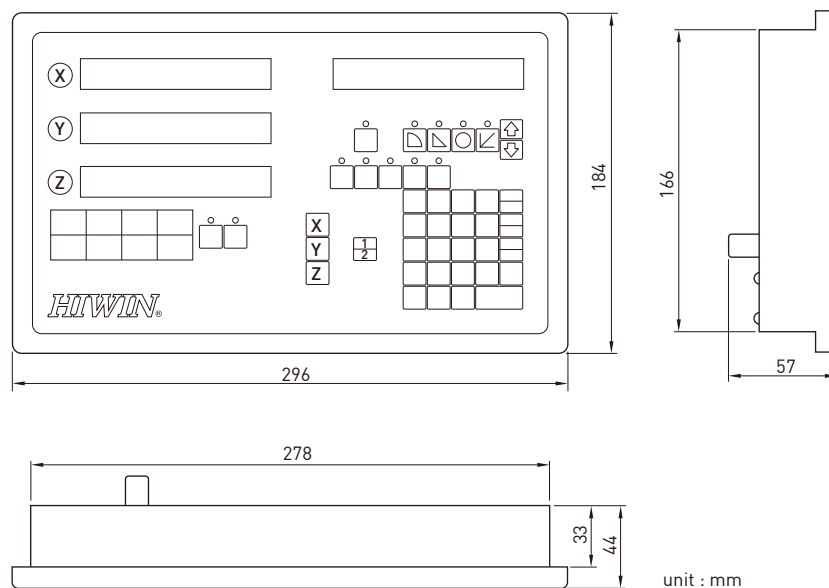

○ Pin assignment of high efficiency multi-axis display, S4

15 pin D-Sub signal
(female)

NC : No connection
FG : Frame ground

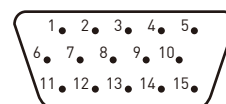

Pin	Designation	Pin	Designation	Pin	Designation
1	+5V	6	FG	11	NC
2	GND	7	NC	12	NC
3	A+	8	NC	13	NC
4	B+	9	NC	14	NC
5	ABS-	10	NC	15	NC

PG Type Positioning Guideway

2-13-3 Accuracy Classes

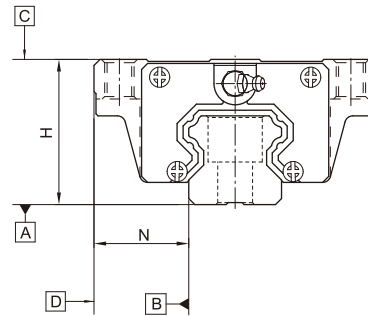

Table 2-13-6 Accuracy Standards of PGH 25, 30, 35

Unit: mm

Accuracy classes	Normal (C)	High (H)	Precision (P)	Super Precision (SP)	Ultra Precision (UP)
Dimensional tolerance of height H	± 0.1	± 0.04	0 - 0.04	0 - 0.02	0 - 0.01
Dimensional tolerance of width N	± 0.1	± 0.04	0 - 0.04	0 - 0.02	0 - 0.01
Variation of height H	0.02	0.015	0.007	0.005	0.003
Variation of width N	0.03	0.015	0.007	0.005	0.003
Running parallelism of block surface C to surface A	See table 2-13-7				
Running parallelism of block surface D to surface B	See table 2-13-7				

Note: See table 2-1-3 and 2-1-5 in section 2-1(HG series) for the accuracy standards of PGH 20, 45, 55

Table 2-13-7 Accuracy of Running Parallelism

Rail length (mm)	Accuracy (μm)				
	C	H	P	SP	UP
~ 100	12	7	3	2	2
100 ~ 200	14	9	4	2	2
200 ~ 300	15	10	5	3	2
300 ~ 500	17	12	6	3	2
500 ~ 700	20	13	7	4	2
700 ~ 900	22	15	8	5	3
900 ~ 1,100	24	16	9	6	3
1,100 ~ 1,500	26	18	11	7	4
1,500 ~ 1,900	28	20	13	8	4
1,900 ~ 2,500	31	22	15	10	5
2,500 ~ 3,100	33	25	18	11	6
3,100 ~ 3,600	36	27	20	14	7
3,600 ~ 4,000	37	28	21	15	7

2-13-4 Preload

Table 2-13-8 PGH-series

Class	Code	Preload
Light Preload	Z0	0~0.02C
Medium Preload	ZA	0.05C~0.07C
Heavy Preload	ZB	0.10C~0.12C

Note: "C" in preload column means basic dynamic load rating

2-13-5 Dimensions for PG Series

(1) PGHH-CA / PGHH-HA

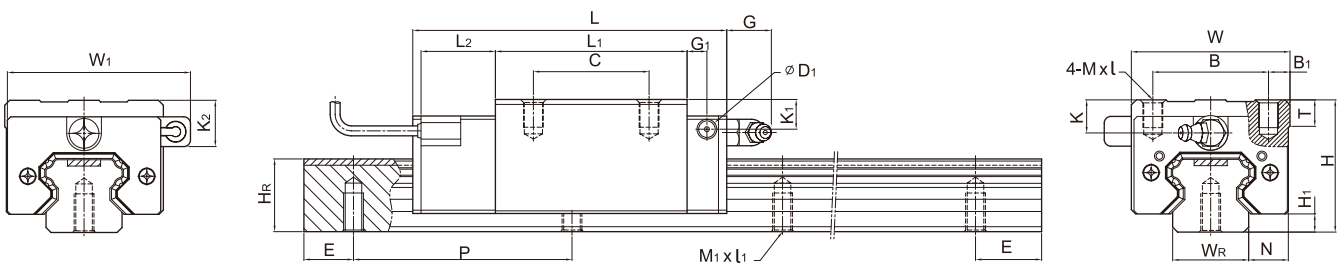

Model No.	Dimensions of Assembly (mm)			Dimensions of Block (mm)																	Dimensions of Rail (mm)					Basic Dynamic Load Rating	Basic Static Load Rating	Weight	
	H	H ₁	N	W	W ₁	B	B ₁	C	L	L ₁	L ₂	G	G ₁	D ₁	K	K ₁	K ₂	M x l	T	W _R	H _R	M ₁ x l ₁	P	E	C (kN)			C ₀ (kN)	Block
PGHH20CA	30	4.6	12	44	52	32	6	36	90.5	50.5	25	12	6	5	6	6	10	M5x6	8	20	17.5	M6x10	60	20	27.1	36.68	0.38	2.05	
PGHH20HA								50	105.2	65.2															42.2	69.07	0.69		
PGHH25CA	40	5.5	12.5	48	55.4	35	6.5	35	95	58	22.5	12	6	5	10	9	14	M6x8	8	23	22	M6x12	60	20	34.9	52.82	0.51	3.05	
PGHH25HA								50	116	78.6															42.2	69.07	0.69		
PGHH30CA	45	6	16	60	67	40	10	40	110	70	23	12	6	5	9.5	13.8	19	M8x10	8.5	28	26	M8x15	80	20	48.5	71.87	0.88	4.31	
PGHH30HA								60	133	93															58.6	93.99	1.16		
PGHH35CA	55	7.5	18	70	77	50	10	50	123	80	23.4	12	7	5	16	19.6	23.5	M8x12	10.2	34	29	M8x17	80	20	64.6	93.88	1.45	6.14	
PGHH35HA								72	148.8	105.8															77.9	122.77	1.92		
PGHH45CA	70	9.5	20.5	86	91	60	13	60	148	97	24.5	12.9	10	8.5	18.5	30.5	30.5	M10x17	16	45	38	M12x24	105	22.5	103.8	146.71	2.73	10.25	
PGHH45HA								80	179.8	128.8															125.3	191.85	3.61		
PGHH55CA	80	13	23.5	100	106	75	12.5	75	172.7	117.7	26	12.9	11	8.5	22	29	28.5	M12x18	17.5	53	44	M14x25	120	30	153.2	211.23	4.17	14.92	
PGHH55HA								95	210.8	155.8															184.9	276.23	5.49		

Note: 1 kgf = 9.81N

PG Type

Positioning Guideway

(2) PGHW-CA / PGHW-HA

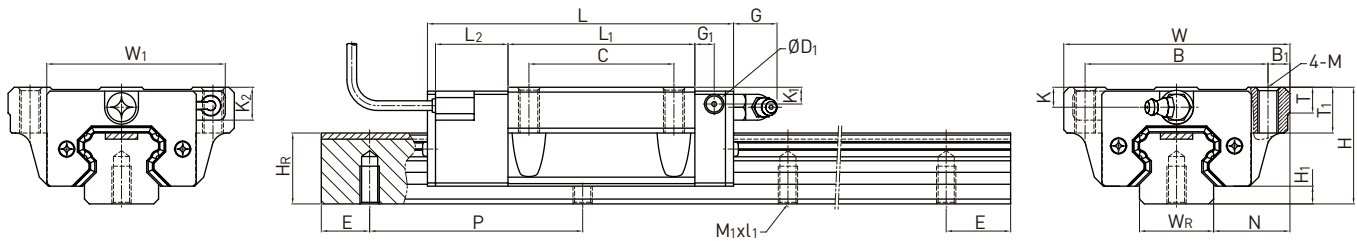

Model No.	Dimensions of Assembly (mm)				Dimensions of Block (mm)																	Dimensions of Rail (mm)					Basic Dynamic Load Rating	Basic Static Load Rating	Weight	
	H	H ₁	N	W	W ₁	B	B ₁	C	L	L ₁	L ₂	G	G ₁	D ₁	M	K	K ₁	K ₂	T	T ₁	W _R	H _R	M ₁ xL ₁	P	E	C(kN)			C ₀ (kN)	Block
PGHW20CA	30	4.6	21.5	63	52	53	5	40	90.5	50.5	25	12	6	5	M6	6	6	10	8	10	20	17.5	M6x10	60	20	27.1	36.68	0.40	2.05	
PGHW20HA								105.2	65.2																					
PGHW25CA	36	5.5	23.5	70	55.4	57	6.5	45	95	58	22.5	12	6	5	M8	6	5	10	8	14	23	22	M6x12	60	20	34.9	52.82	0.59	3.05	
PGHW25HA									116	78.6																				
PGHW30CA	42	6	31	90	67	72	9	52	110	70	23	12	6	5	M10	6.5	10.8	16	8.5	16	28	26	M8x15	80	20	48.5	71.87	1.09	4.31	
PGHW30HA									133	93																				
PGHW35CA	48	7.5	33	100	77	82	9	62	123	80	23.4	12	7	5	M10	9	12.6	16.5	10.1	18	34	29	M8x17	80	20	64.6	93.88	1.56	6.14	
PGHW35HA									148.8	105.8																				
PGHW45CA	60	9.5	37.5	120	91	100	10	80	148	97	24.5	12.9	10	8.5	M12	8.5	20	20	15.1	22	45	38	M12x24	105	22.5	103.8	146.71	2.79	10.25	
PGHW45HA									179.8	128.8																				
PGHW55CA	70	13	43.5	140	106	116	12	95	172.7	117.7	26	12.9	11	8.5	M14	12	19	18.5	17.5	26.5	53	44	M14x25	120	30	153.2	211.23	4.52	14.92	
PGHW55HA									210.8	155.8																				

Note: 1 kgf = 9.81N

(3) PGHW-CB/ PGHW-HB

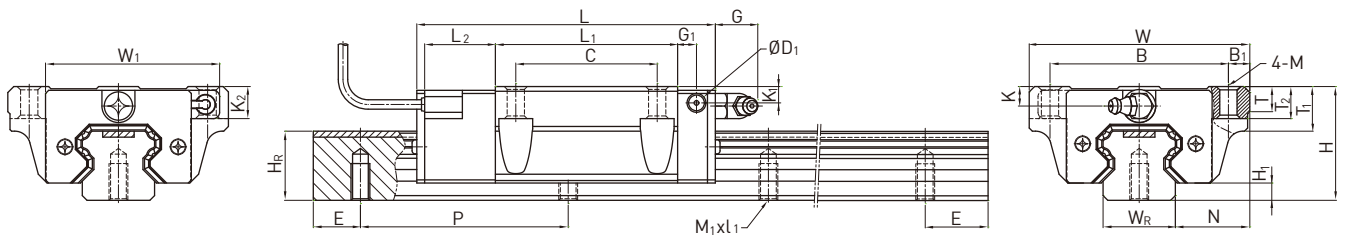

Model No.	Dimensions of Assembly (mm)									Dimensions of Block (mm)														Dimensions of Rail (mm)					Basic Dynamic Load Rating	Basic Static Load Rating	Weight	
	H	H ₁	N	W	W ₁	B	B ₁	C	L	L ₁	L ₂	G	G ₁	D ₁	M	K	K ₁	K ₂	T	T ₁	T ₂	W _R	H _R	M ₁ xL ₁	P	E	C(kN)	C ₀ (kN)			Block kg	Rail kg/m
PGHW20CB	30	4.6	21.5	63	52	53	5	40	90.5	50.5	25	12	6	5	Ø6	6	6	10	8	10	9.5	20	17.5	M6x10	60	20	27.1	36.68	0.40	2.05		
PGHW20HB									105.2	65.2																						
PGHW25CB	36	5.5	23.5	70	55.4	57	6.5	45	95	58	22.5	12	6	5	Ø7	6	5	10	8	14	10	23	22	M6x12	60	20	34.9	52.82	0.59	3.05		
PGHW25HB																																
PGHW30CB	42	6	31	90	67	72	9	52	110	70	23	12	6	5	Ø9	6.5	10.8	16	8.5	16	10	28	26	M8x15	80	20	48.5	71.87	1.09	4.31		
PGHW30HB																																
PGHW35CB	48	7.5	33	100	77	82	9	62	123	80	23.4	12	7	5	Ø9	9	12.6	16.5	10.1	18	13	34	29	M8x17	80	20	64.6	93.88	1.56	6.14		
PGHW35HB																																
PGHW45CB	60	9.5	37.5	120	91	100	10	80	148	97	24.5	12.9	10	8.5	Ø11	8.5	20	20	15.1	22	15	45	38	M12x24	105	22.5	103.8	146.71	2.79	10.25		
PGHW45HB																																
PGHW55CB	70	13	43.5	140	106	116	12	95	172.7	117.7	26	12.9	11	8.5	Ø14	12	19	18.5	17.5	26.5	17	53	44	M14x25	120	30	153.2	211.23	4.52	14.92		
PGHW55HB																																

Note: 1 kgf = 9.81N

PG Type

Positioning Guideway

(4) PGHW-CC/ PGHW-HC

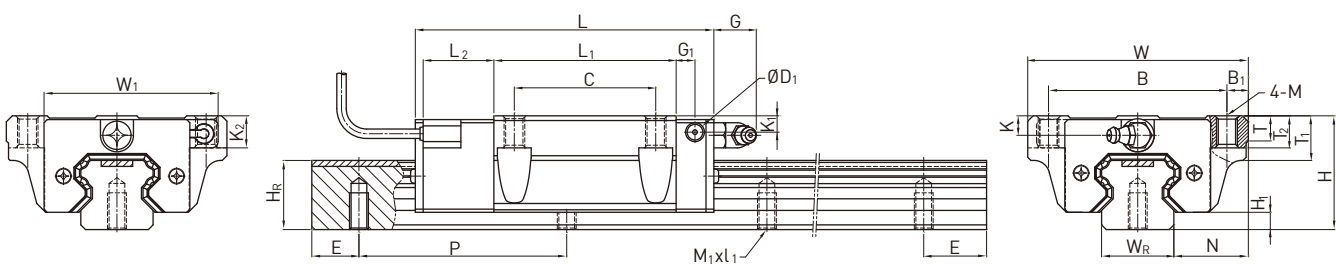

Model No.	Dimensions of Assembly (mm)				Dimensions of Block (mm)																			Dimensions of Rail (mm)					Basic Dynamic Load Rating	Basic Static Load Rating	Weight	
	H	H ₁	N	W	W ₁	B	B ₁	C	L	L ₁	L ₂	G	G ₁	D ₁	M	K	K ₁	K ₂	T	T ₁	T ₂	W _R	H _R	M ₁ xL ₁	P	E	C(kN)	C ₀ (kN)	Block	Rail		
PGHW20CC	30	4.6	21.5	63	52	53	5	40	90.5	50.5	25	12	6	5	M6	6	6	10	8	10	9.5	20	17.5	M6x10	60	20	27.1	36.68	0.40	2.05		
PGHW20HC	105.2	65.2	32.7	47.96	0.52																											
PGHW25CC	36	5.5	23.5	70	55.4	57	6.5	45	95	58	22.5	12	6	5	M8	6	5	10	8	14	10	23	22	M6x12	60	20	34.9	52.82	0.59	3.05		
PGHW25HC									116	78.6																	42.2	69.07	0.80			
PGHW30CC	42	6	31	90	67	72	9	52	110	70	23	12	6	5	M10	6.5	10.8	16	8.5	16	10	28	26	M8x15	80	20	48.5	71.87	1.09	4.31		
PGHW30HC									133	93																	58.6	93.99	1.44			
PGHW35CC	48	7.5	33	100	77	82	9	62	123	80	23.4	12	7	5	M10	9	12.6	16.5	10.1	18	13	34	29	M8x17	80	20	64.6	93.88	1.56	6.14		
PGHW35HC									148.8	105.8																	77.9	122.77	2.06			
PGHW45CC	60	9.5	37.5	120	91	100	10	80	148	97	24.5	12.9	10	8.5	M12	8.5	20	20	15.1	22	15	45	38	M12x24	105	22.5	103.8	146.71	2.79	10.25		
PGHW45HC									179.8	128.8																	125.3	191.85	3.69			
PGHW55CC	70	13	43.5	140	106	116	12	95	172.7	117.7	26	12.9	11	8.5	M14	12	19	18.5	17.5	26.5	17	53	44	M14x25	120	30	153.2	211.23	4.52	14.92		
PGHW55HC									210.8	155.8																	184.9	276.23	5.96			

Note: 1 kgf = 9.81N

(5) PGHL-CA / PGHL-HA

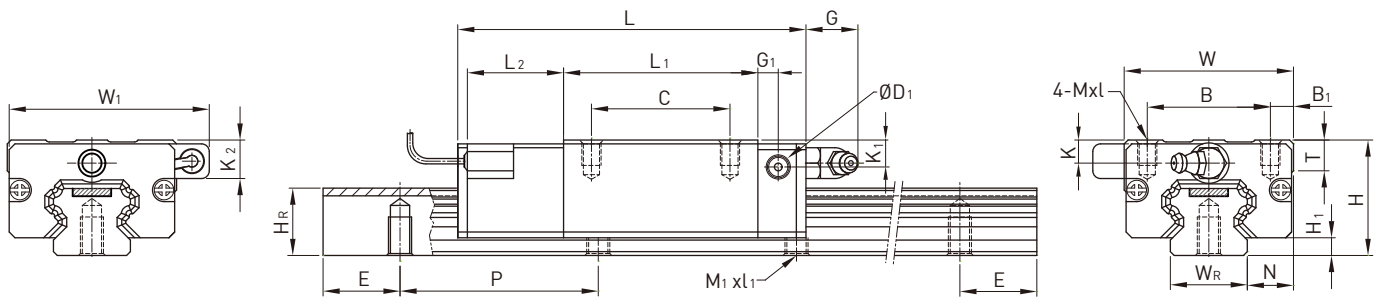

Model No.	Dimensions of Assembly (mm)				Dimensions of Block (mm)																Dimensions of Rail (mm)					Basic Dynamic Load Rating	Basic Static Load Rating	Weight	
	H	H ₁	N	W	W ₁	B	B ₁	C	L	L ₁	L ₂	G	G ₁	D ₁	K	K ₁	K ₂	Mxl	T	W _R	H _R	M ₁ xl ₁	P	E	C(kN)			C ₀ (kN)	kg
PGHL25CA	36	5.5	12.5	48	55.4	35	6.5	35	95	58	22.5	12	6	5	6	9	14	M6x6	8	23	22	M6x12	60	20	34.9	52.82	0.51	3.05	
PGHL25HA								50	116	78.6																			
PGHL30CA	42	6	16	60	67	40	10	40	110	70	23	12	6	5	6.5	10.8	16	M8x10	8.5	28	26	M8x15	80	20	48.5	71.87	0.88	4.31	
PGHL30HA								60	133	93																			
PGHL35CA	48	7.5	18	70	77	50	10	50	123	80	23.4	12	7	5	9	12.6	16.5	M8x12	10.2	34	29	M8x17	80	20	64.6	93.88	1.45	6.14	
PGHL35HA								72	148.8	105.8																			
PGHL45CA	60	9.5	20.5	86	91	60	13	60	148	97	24.5	12.9	10	8.5	8.5	20.5	20.5	M10x17	16	45	38	M12x24	105	22.5	103.8	146.71	2.73	10.25	
PGHL45HA								80	179.8	128.8																			
PGHL55CA	70	13	23.5	100	106	75	12.5	75	172.7	117.7	26	12.9	11	8.5	12	19	18.5	M12x18	17.5	53	44	M14x25	120	30	153.2	211.23	4.17	14.92	
PGHL55HA								95	210.8	155.8																			

Note: 1 kgf = 9.81N

PG Type

Positioning Guideway

(6) Dimensions for PGHR-R (Rail Mounting from Top)

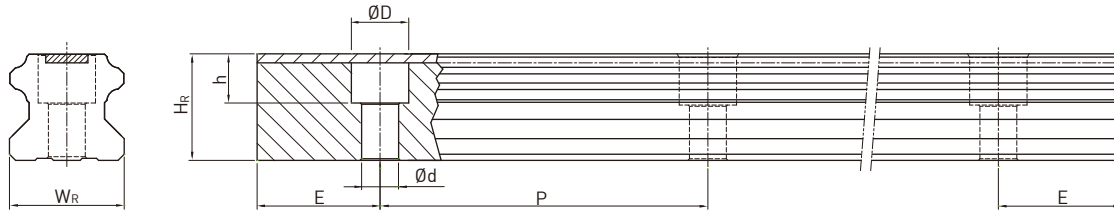

Model No.	Dimensions of Rail (mm)							Mounting Bolt for Rail	Weight
	W_R	H_R	D	h	d	P	E	(mm)	(kg/m)
PGH20R	20	17.5	9.5	8.5	6	60	20	M5×16	2.05
PGH25R	23	22	11	9	7	60	20	M6×20	3.05
PGH30R	28	26	14	12	9	80	20	M8×25	4.31
PGH35R	34	29	14	12	9	80	20	M8×25	6.14
PGH45R	45	38	20	17	14	105	22.5	M12×35	10.25
PGH55R	53	44	23	20	16	120	30	M14×45	14.92