

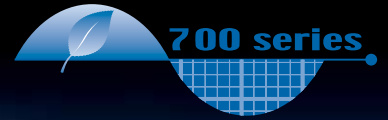

**MITSUBISHI  
ELECTRIC**

*Changes for the Better*

for a greener tomorrow



INVERTER

Model

**FR-A701**

**Highest level of driving performance  
with built-in power regeneration function**



# Inverter with built-in power regeneration function, achieving great braking capability and reduction in wiring length/space saving

The FR-A701 series, which is a high functional inverter FR-A700 series equipped with power regeneration function, achieving great braking capability is now available. This compact body inverter with variety of advanced technology attained high performance suitable for lift operation, line control, etc. It contributes to high performance of machine equipment which generate regeneration torque such as elevator, centrifugal separator, various testing machine, winding machine, etc.

## Features

**Inverter and power regeneration converter are integrated to enclosure and it is easy to perform enclosure designing**

FR-A701

- The number of wires in the main circuit has been reduced to approx.40% and the installation area has been reduced to approx.60% (for 7.5K) compared to the conventional configuration with stand-alone common converters. Use this model to save the wiring and the space.
- For easy replacement, the installation size is the same as the conventional model (FR-A201).
- The braking circuit is built-in for this inverter, so the selection procedure for a braking option is no longer required.

## Comparison (7.5K)

Installation area

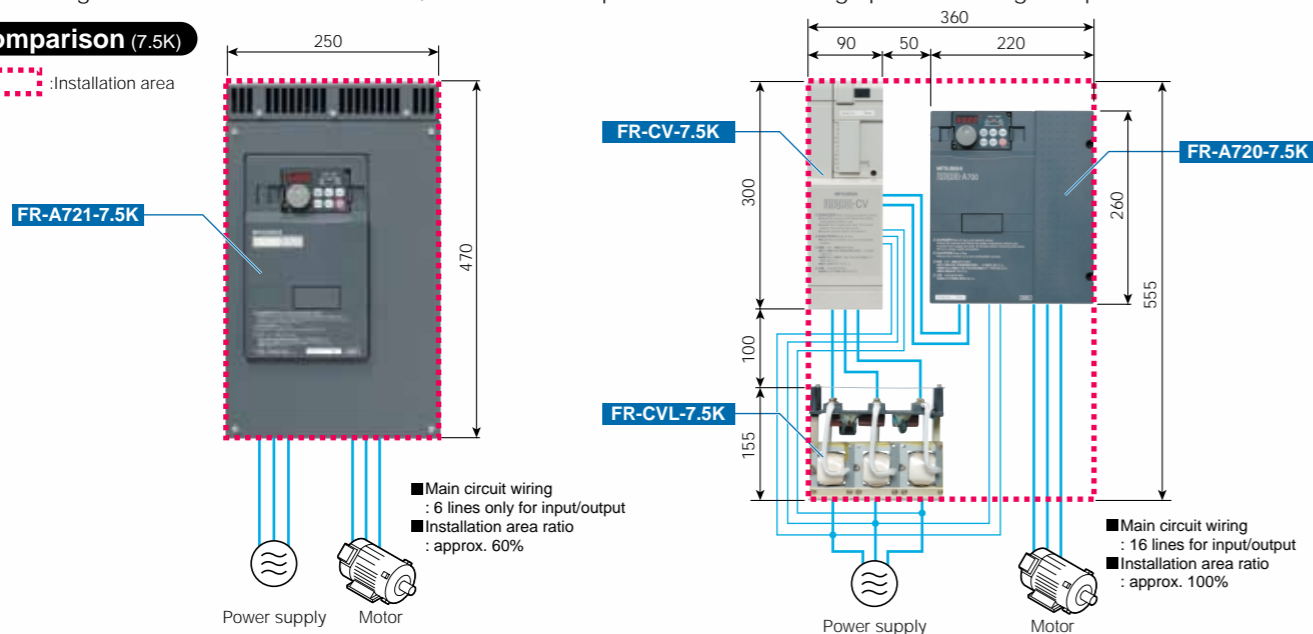

## Great braking capability by power regeneration function

FR-A701

Regenerative braking torque has enough allowance for regeneration; **100% torque continuous and 150% torque 60s.**

## High function/high performance elements of inverter are employed

FR-A701

The FR-A701 is based on the A700 series demonstrating the highest level of driving performance, long-life parts, life diagnosis function, network capability, eco-friendliness\*, simple operation and easy maintenance.

\*: The EMC filter, which was built-in to FR-A700 series, is not available for this series.

## Wide variety of lineup

FR-A701

Wide variations from 5.5kW to 55kW for the 200V class and 400V class each are available.

## Total cost-reduction can be achieved

FR-A701

The total cost is reduced compared to the conventional system (inverter + power regenerative converter + AC reactor). Less heat is generated in this inverter because the regenerative power is returned to the power supply, leading to energy savings.

## Overseas standard/EU restriction of the use of certain hazardous substances (RoHS) directive compliance

FR-A701

- This product is certified by UL and cUL.
- Complies with EC Directive (CE marking). (400V class only)

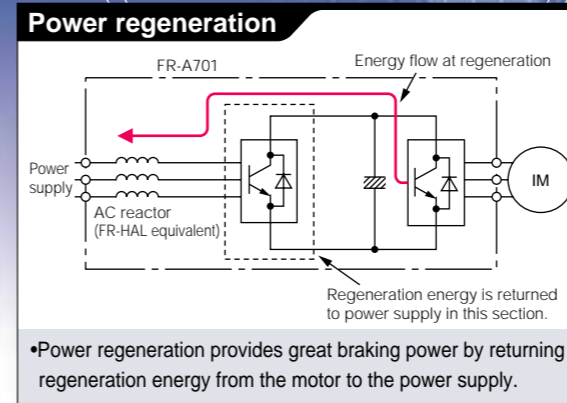

## Model configuration

### FR - A721 - 5.5K

Symbol	Voltage class	Symbol	Applicable motor capacity
A721	200V class	5.5K	Indicate capacity (kW)
A741	400V class	55K	

Applied motor (kW)	5.5	7.5	11	15	18.5	22	30	37	45	55
Three-phase 200V class FR-A721-□□	●	●	●	●	●	●	●	●	●	●
Three-phase 400V class FR-A741-□□	●	●	●	●	●	●	●	●	●	●

● : Available models

## Applications

### •Multilevel car parking tower

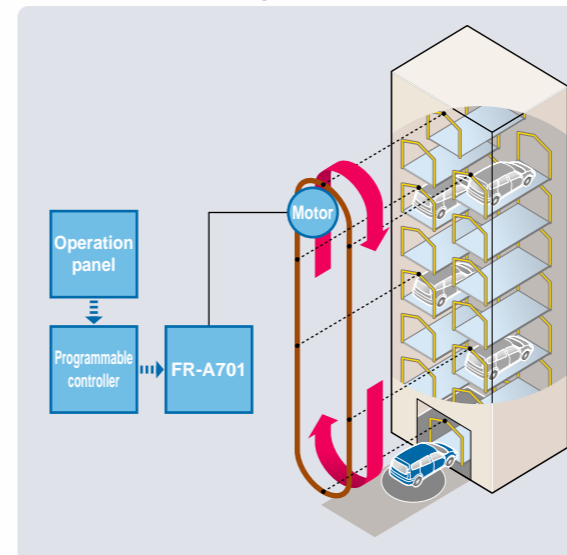

### •Overhead crane

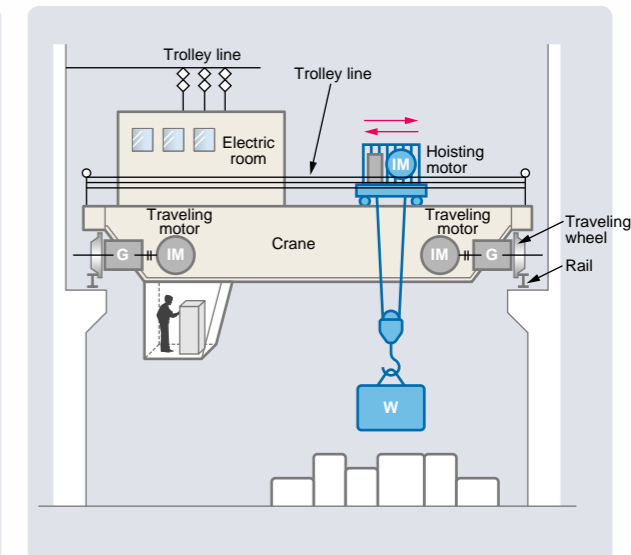

## Characteristic

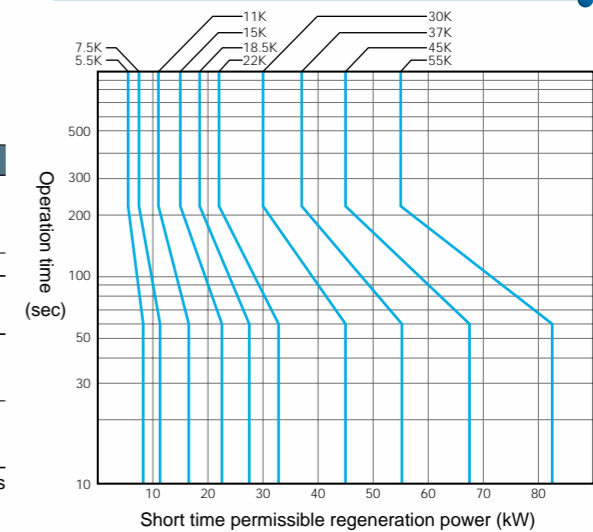

• Features 1

• Standard specifications 3

• Outline Dimension Drawings 5

• Terminal Connection Diagram  
• Terminal Specification Explanation 10

• Parameter List 13

• Protective Functions 24

• Option and Peripheral Devices 26

• Precautions for Operation/Selection  
• Precautions for Peripheral Device Selection 33

• Warranty 37

• Service  
• International FA Center 38

# Standard Specifications

## Rating

### ●200V class

Model FR-A721-□□K	5.5	7.5	11	15	18.5	22	30	37	45	55	
Applicable motor capacity (kW) *1	5.5	7.5	11	15	18.5	22	30	37	45	55	
Output	Rated capacity (kVA) *2	9.2	12.6	17.6	23.3	29	34	44	55	67	82
	Rated current (A)	24	33	46	61	76	90	115	145	175	215
	Overload current rating *3	150% 60s, 200% 3s (inverse-time characteristics) surrounding air temperature 50°C									
	Rated voltage *4	Three-phase 200 to 240V									
	Regenerative braking torque	100% continuous 150% 60s									
Power supply	Rated input AC voltage/frequency	Three-phase 200 to 220V 50Hz, 200 to 240V 60Hz									
	Permissible AC voltage fluctuation	170 to 242V 50Hz, 170 to 264V 60Hz									
	Permissible frequency fluctuation	±5%									
	Power supply capacity (kVA) *5	12	17	20	28	34	41	52	66	80	100
Protective structure (JEM 1030) *6	Open type (IP00)										
Cooling system	Forced air cooling										
Approx. mass (kg)	20	22	33	35	50	52	69	87	90	120	

### ●400V class

Model FR-A741-□□K	5.5	7.5	11	15	18.5	22	30	37	45	55	
Applicable motor capacity (kW) *1	5.5	7.5	11	15	18.5	22	30	37	45	55	
Output	Rated capacity (kVA) *2	9.1	13	17.5	23.6	29	32.8	43.4	54	65	84
	Rated current (A)	12	17	23	31	38	44	57	71	86	110
	Overload current rating *3	150% 60s, 200% 3s (inverse-time characteristics) surrounding air temperature 50°C									
	Rated voltage *4	Three-phase 380 to 480V									
	Regenerative braking torque	100% continuous 150% 60s									
Power supply	Rated input AC voltage/frequency	Three-phase 380 to 480V 50Hz/60Hz									
	Permissible AC voltage fluctuation	323 to 528V 50Hz/60Hz									
	Permissible frequency fluctuation	±5%									
	Power supply capacity (kVA) *5	12	17	20	28	34	41	52	66	80	100
Protective structure *6	Open type (IP00)										
Cooling system	Forced air cooling										
Approx. mass (kg)	25	26	37	40	48	49	65	80	83	115	

\*1. The applicable motor capacity indicated is the maximum capacity applicable for use of the Mitsubishi 4-pole standard motor.

\*2. The rated output capacity indicated assumes that the output voltage is 220V for 200V and 440V for 400V class.

\*3. The % value of the overload current rating indicated is the ratio of the overload current to the inverter's rated output current. For repeated duty, allow time for the inverter and motor to return to or below the temperatures under 100% load.

\*4. The maximum output voltage does not exceed the power supply voltage. The maximum output voltage can be changed within the setting range. However, the pulse voltage value of the inverter output side voltage remains unchanged at about  $\sqrt{2}$  that of the power supply.

\*5. The power supply capacity varies with the value of the power supply side inverter impedance (including those of the input reactor and cables).

\*6. FR-DU07:IP40 (except for the PU connector)

## Common Specifications

Control specifications	Control method		Soft-PWM control/high carrier frequency PWM control (V/F control, Advanced magnetic flux vector control and Real sensorless vector control are available) / vector control *1
	Output frequency range		0.2 to 400Hz (The maximum frequency is 120Hz under Real sensorless vector control and vector control.)
	Frequency setting resolution	Analog input	0.015Hz/60Hz (terminal 2, 4: 0 to 10V/12bit) 0.03Hz/60Hz (terminal 2, 4: 0 to 5V/11bit, 0 to 20mA/about 11bit, terminal 1: 0 to ±10V/12bit) 0.06Hz/60Hz (terminal 1: 0 to ±5V/11bit)
		Digital input	0.01Hz
	Frequency accuracy	Analog input	Within ±0.2% of the max. output frequency (25°C±10°C)
		Digital input	Within 0.01% of the set output frequency
	Voltage/frequency characteristics		Base frequency can be set from 0 to 400Hz. Constant torque/variable torque pattern or adjustable 5 points V/F can be selected
	Starting torque		150% at 0.3Hz (Under Real sensorless vector control or vector control *1)
	Torque boost		Manual torque boost
	Acceleration/deceleration time setting		0 to 3600s (acceleration and deceleration can be set individually), linear or S-pattern acceleration/deceleration mode, backlash measures acceleration/deceleration mode are available.
DC injection brake		Operation frequency (0 to 120Hz), operation time (0 to 10s), operation voltage (0 to 30%) can be changed	
Stall prevention operation level		Operation current level can be set (0 to 220% adjustable), whether to use the function or not can be selected	
Torque limit level		Torque limit value can be set (0 to 400% variable)	
Operation specifications	Frequency setting signal	Analog input	• Terminal 2, 4: 0 to 10V, 0 to 5V, 4 to 20mA (0 to 20mA) can be selected • Terminal 1: -10 to +10V, -5 to +5V can be selected
		Digital input	Input using the setting dial of the operation panel or parameter unit Four-digit BCD or 16 bit binary (when used with option FR-A7AX)
	Start signal		Forward and reverse rotation or start signal automatic self-holding input (3-wire input) can be selected.
	Input signals (twelve terminals)		The following signals can be assigned to Pr. 178 to Pr. 189 (input terminal function selection): multi speed selection, remote setting, stop-on-contact, second function selection, third function selection, terminal 4 input selection, JOG operation selection, selection of automatic restart after instantaneous power failure, flying start, external thermal relay input, PU operation/External inter lock signal, external DC injection brake operation start, PID control enable terminal, brake opening completion signal, PU operation/External operation switchover, load pattern selection forward rotation reverse rotation boost, V/F switching, load torque high-speed frequency, S-pattern acceleration/deceleration C switchover, pre-excitation, output stop, start self-holding selection, control mode changing, torque limit selection, start-time tuning start external input, torque bias selection 1, 2*1, P/PI control switchover, forward rotation command, reverse rotation command, inverter reset, PTC thermistor input, PID forward reverse operation switchover, PU/NET operation switchover, NET/External operation switchover, command source switchover, simple position pulse train sign*1, simple position droop pulse clear*1, magnetic flux decay output shutoff.
	Pulse train input		100kpps
	Operational functions		Maximum/minimum frequency setting, frequency jump operation, external thermal relay input selection, polarity reversible operation, automatic restart after instantaneous power failure operation, electronic bypass operation, forward/reverse rotation prevention, remote setting, brake sequence, second function, third function, multi-speed operation, original operation continuation at instantaneous power failure, stop-on-contact control, load torque high speed frequency control, droop control, regeneration avoidance, slip compensation, operation mode selection, offline auto tuning function, online auto tuning function, PID control, computer link operation (RS-485), motor end orientation *1, machine end orientation *2, pre-excitation, notch filter, machine analyzer *1, easy gain tuning, speed feed forward, and torque bias *1
	Output signals		The following signals can be assigned to Pr. 190 to Pr. 196 (output terminal function selection): inverter running, inverter running/start command on, up-to-frequency, instantaneous power failure/undervoltage, overload warning, output frequency (speed) detection, second output frequency (speed) detection, third output frequency (speed) detection, electronic thermal O/L relay pre-alarm, PU operation mode, inverter operation ready, output current detection, zero current detection, PID lower limit, PID upper limit, PID forward rotation reverse rotation output, electronic bypass MC1, electronic bypass MC2, electronic bypass MC3, orientation complete *1, orientation fault *1, brake opening request, fan fault output, heatsink overheat pre-alarm, deceleration at an instantaneous power failure, PID control activated, during retry, PID output interruption, position control preparation ready *1, life alarm, fault output 1, 2, 3 (power-off signal), power savings average value update timing, current average monitor, maintenance timer alarm, remote output, forward rotation output *1, low speed output, torque detection, regenerative status output *1, start-time tuning completion, in-position completion *1, alarm output and fault output. Alarm code of the inverter can be output (4 bit) from the open collector.
	Open collector output (5 terminals) relay output (1 terminal)		
	Operating status		In addition to above, the following signal can be assigned to Pr.313 to Pr. 319 (extension output terminal function selection): control circuit capacitor life, main circuit capacitor life, cooling fan life, inrush current limit circuit life. (only positive logic can be set for extension terminals of the FR-A7AR)
	Pulse train output		50kpps
For meter		The following signals can be assigned to Pr. 54 FM terminal function selection (pulse train output) and Pr. 158 AM terminal function selection (analog output): output frequency, motor current (steady or peak value), output voltage, frequency setting, operation speed, motor torque, converter output voltage (steady or peak value), electronic thermal relay function load factor, input power, output power, load meter, motor excitation current, reference voltage output, motor load factor, power saving effect, PID set point, PID measured value, motor output, torque command, torque current command, and torque monitor.	
Indication	Operation panel (FR-DU07)	Operating status	
		Fault record	
	Parameter unit (FR-PU07)	Interactive guidance	
		Function (help) for operation guide*4	
Protective/warning function	Protective function		
	Warning function		
Environment	Surrounding air temperature		-10°C to +50°C (non-freezing)
	Ambient humidity		90%RH maximum (non-condensing)
	Storage temperature*5		-20°C to +65°C
	Atmosphere		Indoors (without corrosive gas, flammable gas, oil mist, dust and dirt etc.)
	Altitude/vibration		Maximum 1000m above sea level for standard operation. 5.9m/s <sup>2</sup> or less at 10 to 55Hz (directions of X, Y, Z axes)

\*1 Available only when the option (FR-A7AP/FR-A7AL) is mounted.

\*2 Available only when the option (FR-A7AL) is mounted.

\*3 Can be displayed only on the operation panel (FR-DU07).

\*4 Can be displayed only on the parameter unit (FR-PU07).

\*5 Temperature applicable for a short period in transit, etc.

\*6 This protective function is not available in the initial status.

Features  
Standard Specifications  
Outline Dimension Drawings  
Terminal Connection Diagram Terminal Specification Explanation  
Parameter List  
Protective Functions  
Options  
Instructions  
Warranty  
Inquiry

# Outline Dimension Drawings

- FR-A721-5.5K, 7.5K
- FR-A741-5.5K, 7.5K

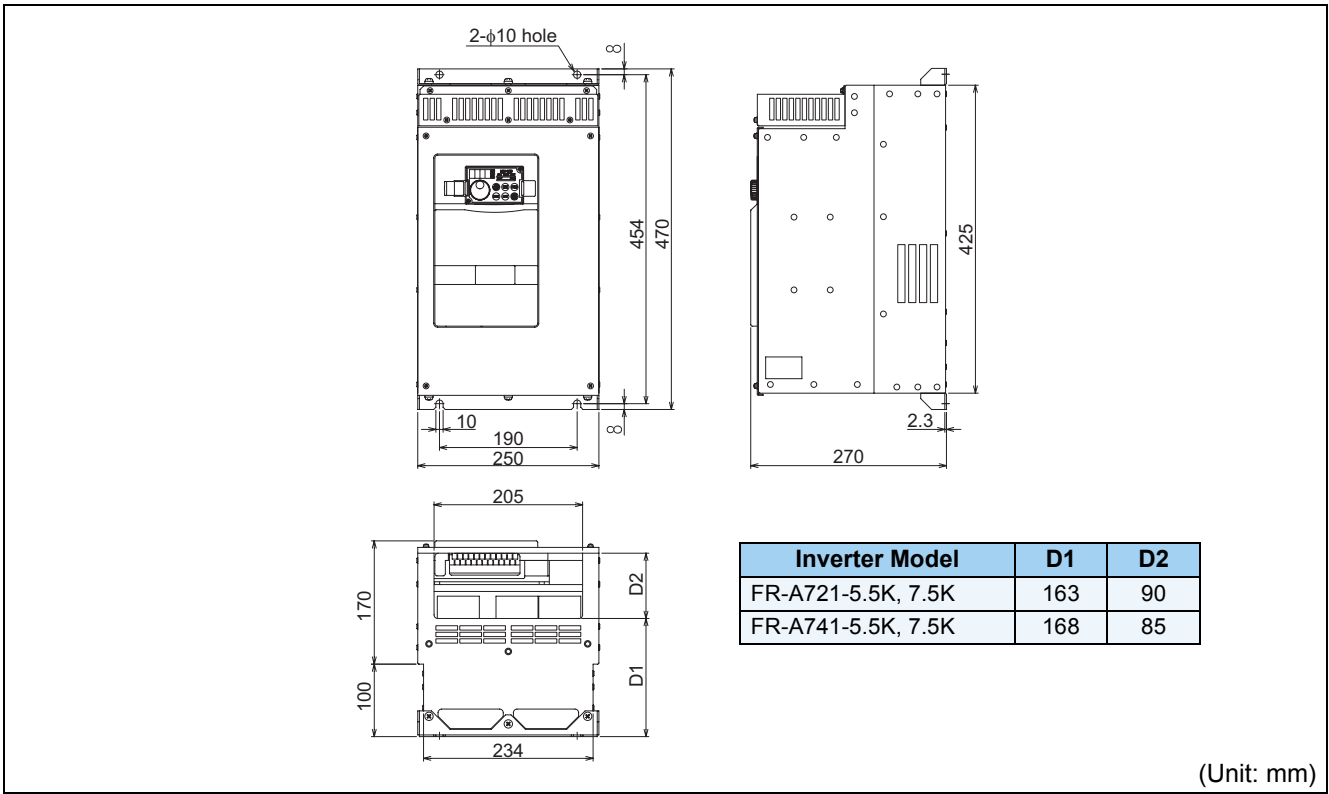

- FR-A721-11K, 15K
- FR-A741-11K, 15K

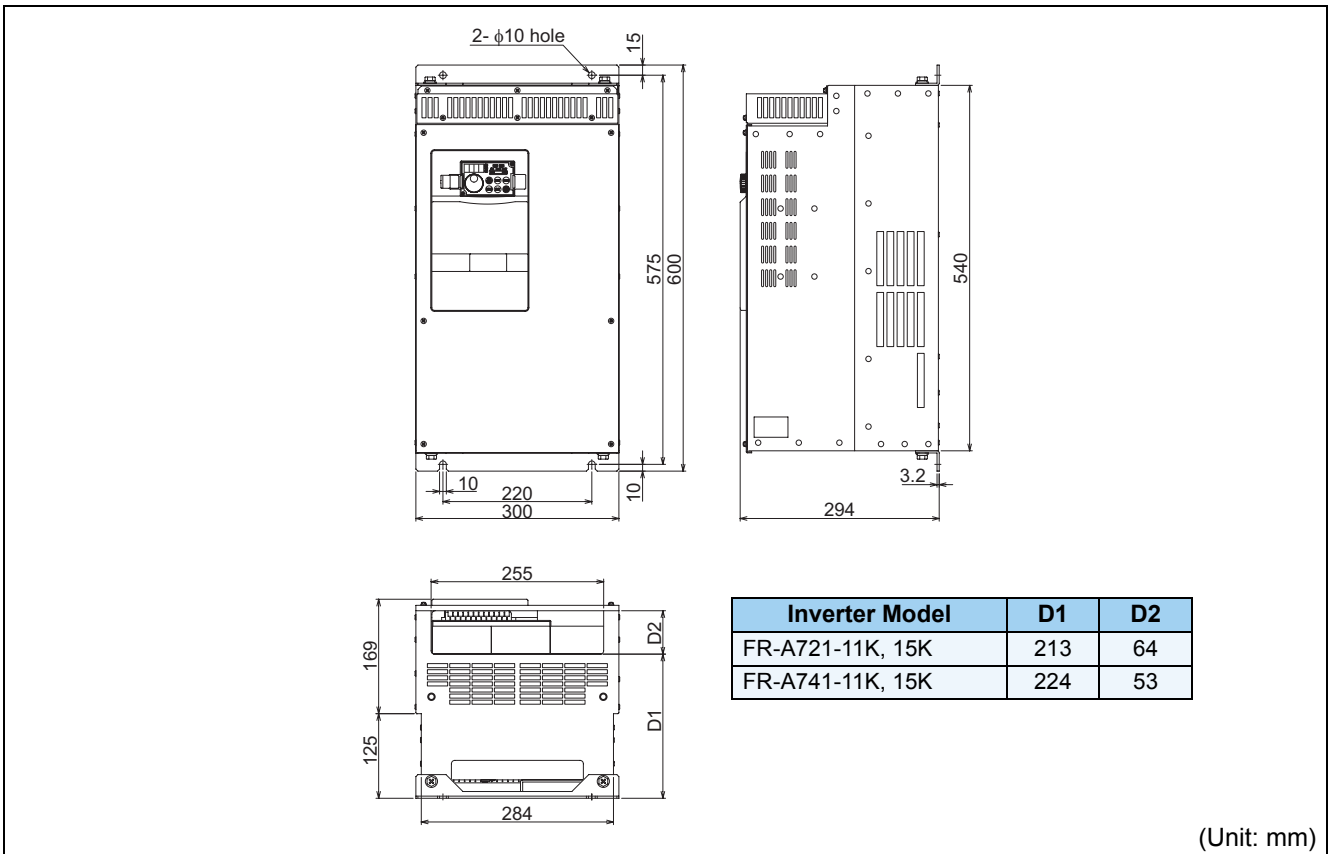

- FR-A721-18.5K, 22K
- FR-A741-18.5K, 22K

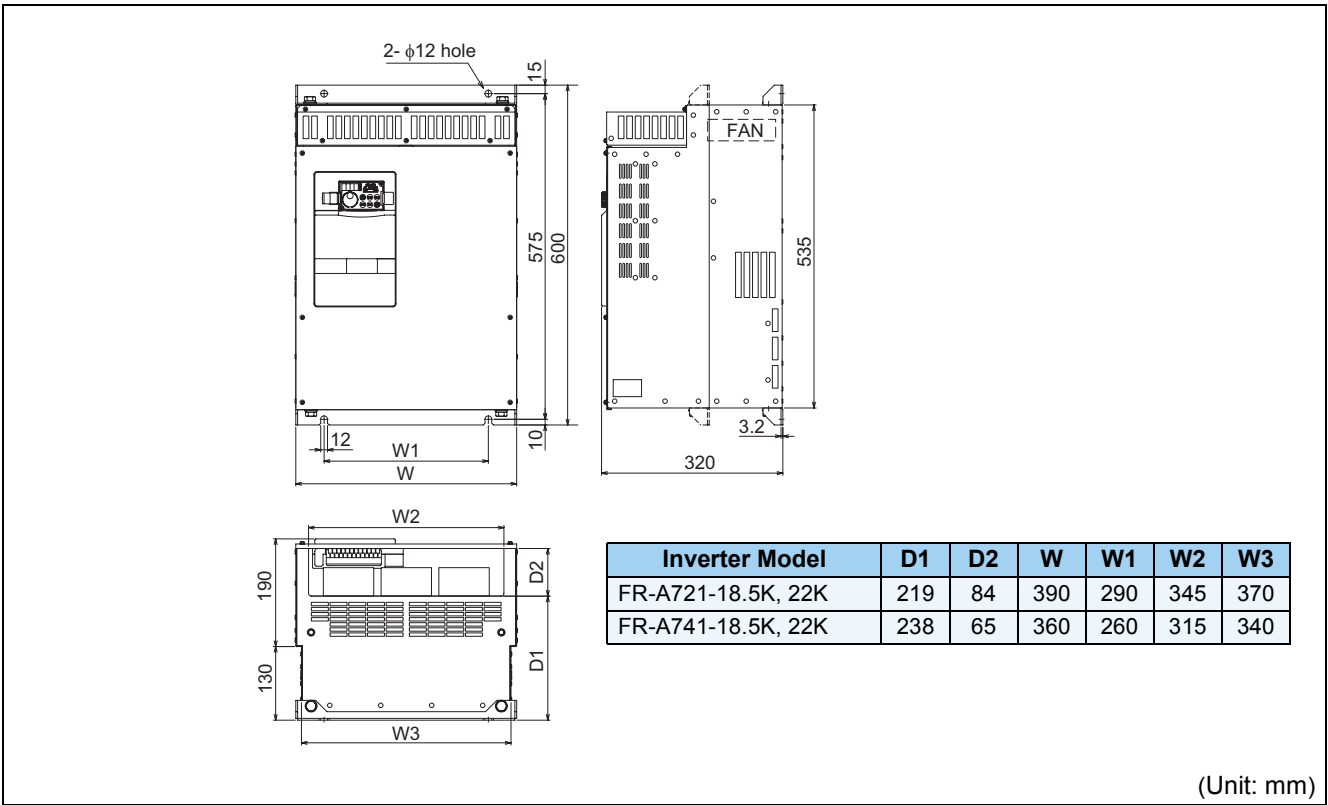

- FR-A721-30K
- FR-A741-30K

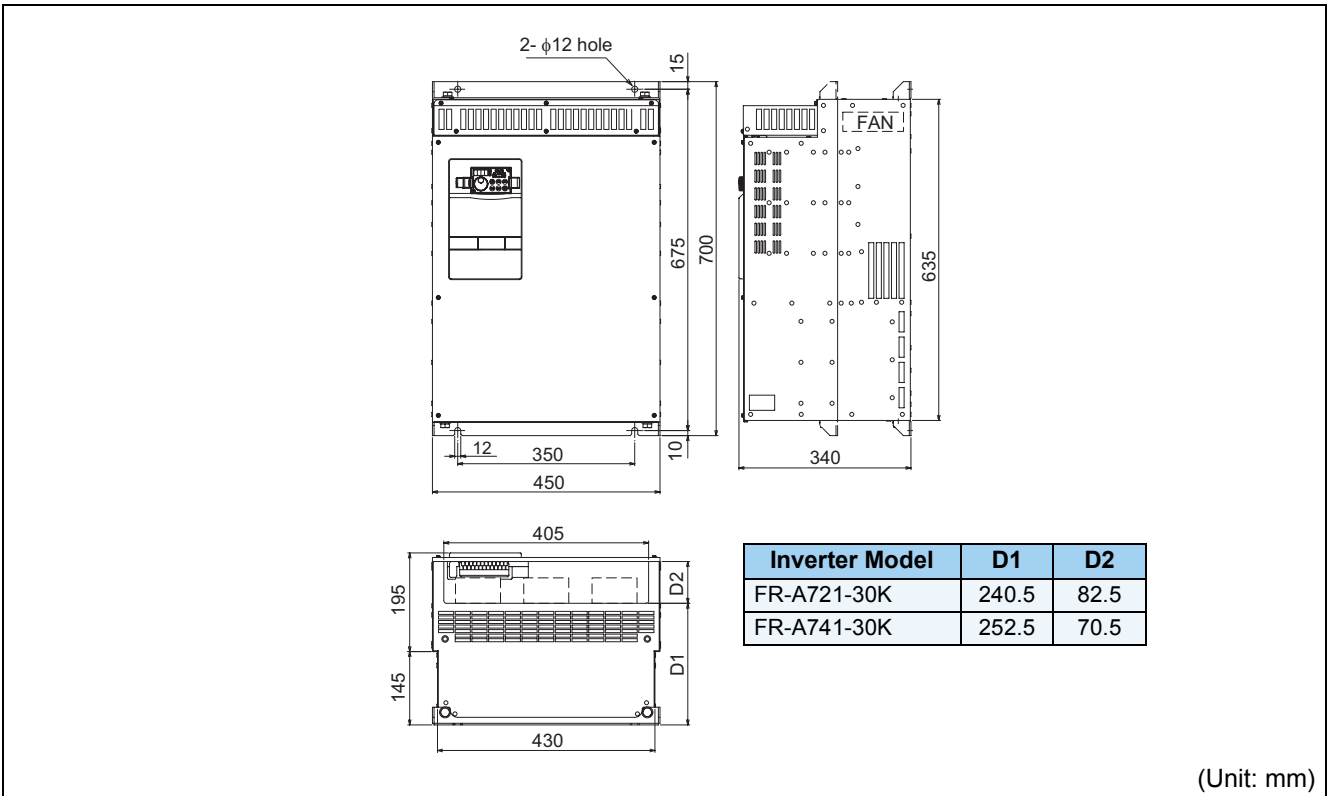

Features

Standard Specifications

Outline Dimension Drawings

Terminal Connection Diagram, Terminal Specification Explanation

Parameter List

Protective Functions

Options

Instructions

Warranty

Inquiry

- FR-A721-37K, 45K
- FR-A741-37K, 45K

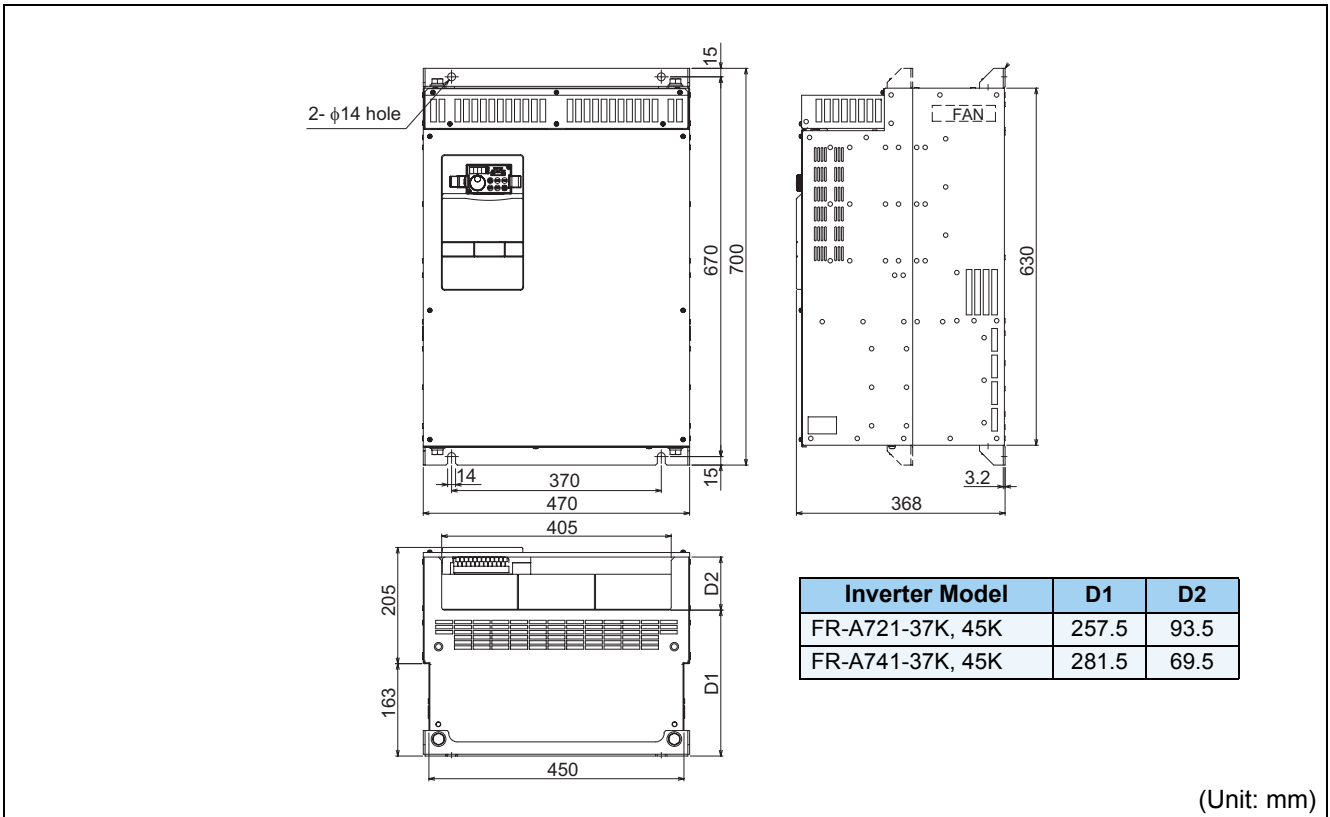

- FR-A721-55K
- FR-A741-55K

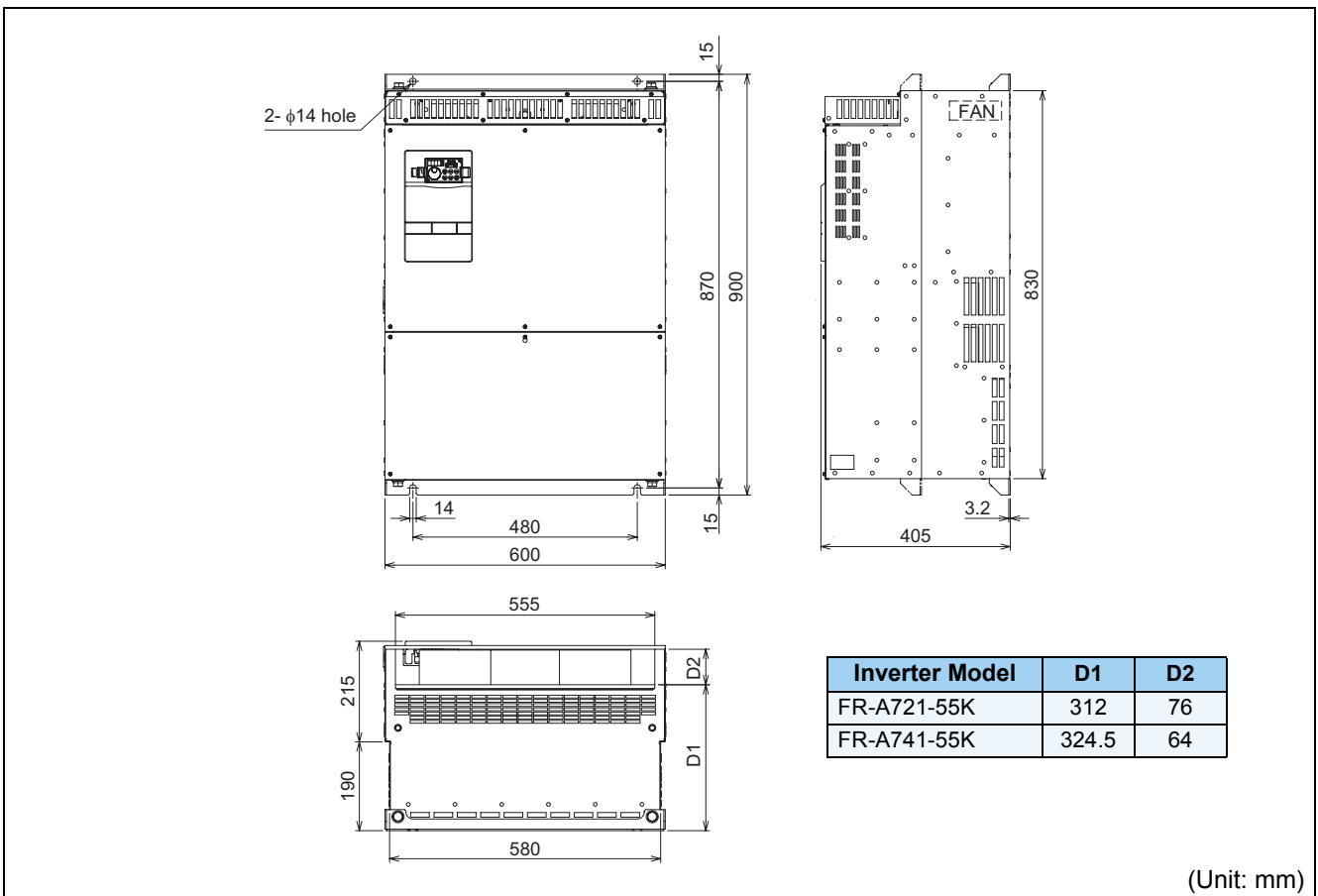

## Heatsink protrusion procedure

When encasing the inverter in an enclosure, the generated heat amount in an enclosure can be greatly reduced by installing the heatsink portion of the inverter outside the enclosure.

When installing the inverter in a compact enclosure, etc., this installation method is recommended.

### ●Protrusion of heatsink

#### ● Panel cutting

Cut the panel of the enclosure according to the inverter capacity.

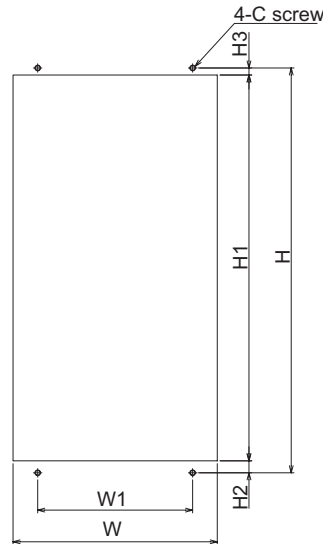

Inverter Model	W	W1	H	H1	H2	H3	C
FR-A721-5.5K, 7.5K FR-A741-5.5K, 7.5K	240	190	454	434	12	8	M8
FR-A721-11K, 15K FR-A741-11K, 15K	290	220	575	548	17	10	M8
FR-A721-18.5K, 22K	376	290	575	546	17	12	M10
FR-A741-18.5K, 22K	346	260	575	546	17	12	M10
FR-A721-30K FR-A741-30K	436	350	675	646	17	12	M10
FR-A721-37K, 45K FR-A741-37K, 45K	456	370	670	641	17	12	M12
FR-A721-55K FR-A741-55K	586	480	870	841	17	12	M12

(Unit: mm)



● Shift and removal of a rear side installation frame

One installation frame is attached to each of the upper and lower parts of the inverter. Change the position of the rear side installation frame on the upper and lower sides of the inverter to the front side as shown on the right. When changing the installation frames, make sure that the installation orientation is correct.

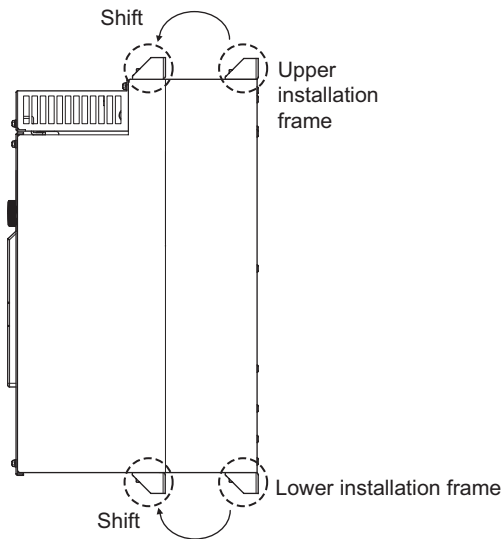

● Installation of the inverter

Push the inverter heatsink portion outside the enclosure and fix the enclosure and inverter with upper and lower installation frame.

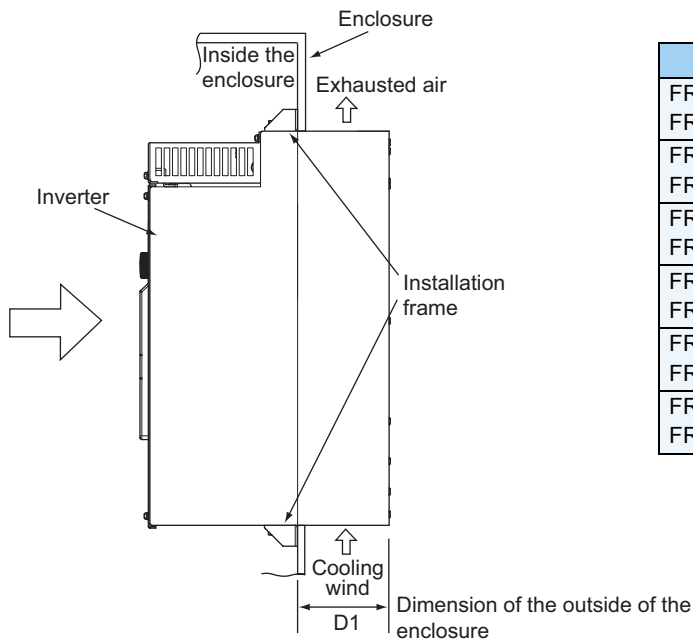

Inverter Model	D1
FR-A721-5.5K, 7.5K FR-A741-5.5K, 7.5K	100
FR-A721-11K, 15K FR-A741-11K, 15K	125
FR-A721-18.5K, 22K FR-A741-18.5K, 22K	130
FR-A721-30K FR-A741-30K	145
FR-A721-37K, 45K FR-A741-37K, 45K	163
FR-A721-55K FR-A741-55K	190

(Unit: mm)

**CAUTION**

- Having a cooling fan, the cooling section which comes out of the enclosure can not be used in the environment of water drops, oil, mist, dust, etc.
- Be careful not to drop screws, dust, etc. into the inverter and cooling fan section.

# Terminal Connection Diagram

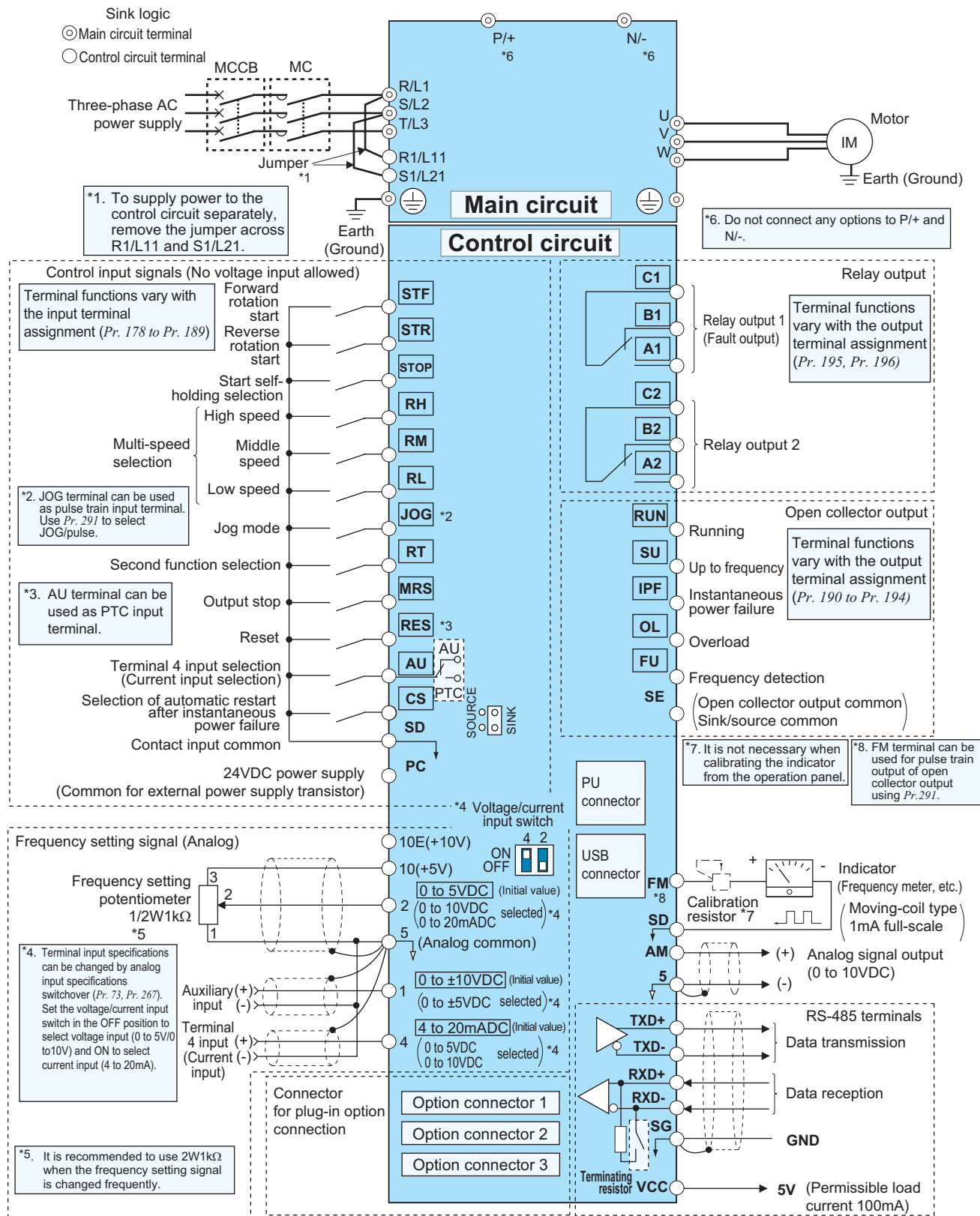

### CAUTION

- To prevent a malfunction caused by noise, separate the signal cables more than 10cm from the power cables. Also separate the main circuit wire of the input side and output side.
- After wiring, wire offcuts must not be left in the inverter.  
Wire offcuts can cause an alarm, failure or malfunction. Always keep the inverter clean.
- When drilling mounting holes in an enclosure etc., take care not to allow chips and other foreign matter to enter the inverter.
- Set the voltage/current input switch correctly. Different setting may cause a fault, failure or malfunction.

Features  
 Standard Specifications  
 Outline Dimension Drawings  
 Terminal Connection Diagram Terminal Specification Explanation  
 Parameter List  
 Protective Functions  
 Options  
 Instructions  
 Warranty  
 Inquiry

# Terminal Specification Explanation

Type	Terminal Symbol	Terminal Name	Description		
Main circuit	R/L1, S/L2, T/L3	AC power input	Connect to the commercial power supply.		
	U, V, W	Inverter output	Connect a three-phase squirrel-cage motor.		
	R1/L11, S1/L21	Power supply for control circuit	<p>Connected to the AC power supply terminals R/L1 and S/L2. To retain the fault display and fault output, remove the jumpers from terminals R/L1-R1/L11 and S/L2-S1/L21 and apply external power to these terminals.</p> <p>Do not turn off the power supply for control circuit (R1/L11, S1/L21) with the main circuit power (R/L1, S/L2, T/L3) on. Doing so may damage the inverter. The circuit should be configured so that the main circuit power (R/L1, S/L2, T/L3) is also turned off when the power supply for control circuit (R1/L11, S1/L21) is off.</p> <p>The following power supply capacities are required to supply power separately from R1/L11 and S1/L21: 90VA for 15K or lower, 100VA for 18.5K or higher</p>		
	P/+, N/-	DC terminal	Do not connect an option directly to P/+, N/-		
	⊕	Earth (Ground)	For earthing (grounding) the inverter chassis. Must be earthed (grounded).		
Control circuit/input signals	STF	Forward rotation start	Turn on the STF signal to start forward rotation and turn it off to stop.	When the STF and STR signals are turned on simultaneously, the stop command is given.	
		Reverse rotation start	Turn on the STR signal to start reverse rotation and turn it off to stop.		
	STOP	Start self-holding selection	Turn on the STOP signal to self-hold the start signal.		
	RH, RM, RL	Multi-speed selection	Multi-speed can be selected according to the combination of RH, RM and RL signals.		
	JOG	Jog mode selection	Turn on the JOG signal to select Jog operation (initial setting) and turn on the start signal (STF or STR) to start Jog operation.		
		Pulse train input	JOG terminal can be used as pulse train input terminal. To use as pulse train input terminal, the Pr. 291 setting needs to be changed. (maximum input pulse: 100kpulses/s)		
	RT	Second function selection	Turn on the RT signal to select second function. When the second function such as "second torque boost" and "second V/F (base frequency)" are set, turning on the RT signal selects these functions.		
	MRS	Output stop	Turn on the MRS signal (20ms or more) to stop the inverter output. Use to shut off the inverter output when stopping the motor by electromagnetic brake.		
	RES	Reset	Used to reset fault output provided when fault occurs. Turn on the RES signal for more than 0.1s, then turn it off. Initial setting is for reset always. By setting Pr. 73, reset can be set to enabled only at fault occurrence. Recover about 1s after reset is cancelled.		
	AU	Terminal 4 input selection	Terminal 4 is valid only when the AU signal is turned on. (The frequency setting signal can be set between 4 and 20mADC.) Turning the AU signal on makes terminal 2 (voltage input) invalid.		
		PTC input	AU terminal is used as PTC input terminal (thermal protection of the motor). When using it as PTC input terminal, set the AU/PTC switch to PTC.		
	CS	Selection of automatic restart after instantaneous power failure	When the CS signal is left on, the inverter restarts automatically at power restoration. Note that restart setting is necessary for this operation. In the initial setting, a restart is disabled.		
	SD	Contact input common (sink) (initial setting)	Common terminal for contact input terminal (sink logic) and terminal FM.		
		External transistor common (source)	Connect this terminal to the power supply common terminal of a transistor output (open collector output) device, such as a programmable controller, in the source logic to avoid malfunction by undesirable current.		
		24VDC power supply common	Common output terminal for 24VDC 0.1A power supply (PC terminal). Isolated from terminals 5 and SE.		
	PC	External transistor common (sink) (initial setting)	Connect this terminal to the power supply common terminal of a transistor output (open collector output) device, such as a programmable controller, in the sink logic to avoid malfunction by undesirable current.		
		Contact input common (source)	Common terminal for contact input terminal (source logic).		
		24VDC power supply	Can be used as 24VDC 0.1A power supply.		
	Frequency setting	10E	Frequency setting power supply	When connecting the frequency setting potentiometer at an initial status, connect it to terminal 10.	10VDC, Permissible load current 10mA
		10		Change the input specifications of terminal 2 when connecting it to terminal 10E.	5VDC, Permissible load current 10mA
2		Frequency setting (voltage)	Inputting 0 to 5VDC (or 0 to 10V, 0 to 20mA) provides the maximum output frequency at 5V (10V, 20mA) and makes input and output proportional. Use Pr. 73 to switch from among input 0 to 5VDC (initial setting), 0 to 10VDC, and 0 to 20mA. Set the voltage/current input switch in the ON position to select current input (0 to 20mA).	Voltage input: Input resistance 10kΩ ± 1kΩ Maximum permissible voltage 20VDC Current input: Input resistance 245Ω ± 5Ω Maximum permissible current 30mA	
4		Frequency setting (current)	Inputting 4 to 20mADC (or 0 to 5V, 0 to 10V) provides the maximum output frequency at 20mA makes input and output proportional. This input signal is valid only when the AU signal is on (terminal 2 input is invalid). Use Pr. 267 to switch from among input 4 to 20mA (initial setting), 0 to 5VDC, and 0 to 10VDC. Set the voltage/current input switch in the OFF position to select voltage input (0 to 5V/0 to 10V). Use Pr. 858 to switch terminal functions.		
1		Frequency setting auxiliary	Inputting 0 to ±5 VDC or 0 to ±10VDC adds this signal to terminal 2 or 4 frequency setting signal. Use Pr. 73 to switch between the input 0 to ±5VDC and 0 to ±10VDC (initial setting). Use Pr. 868 to switch terminal functions. Input resistance 10kΩ ± 1kΩ Maximum permissible voltage ± 20VDC		
5		Frequency setting common	Common terminal for frequency setting signal (terminal 2, 1 or 4) and analog output terminal AM. Do not earth (ground).		

Type	Terminal Symbol	Terminal Name	Description	
Control circuit/output signals	Relay	A1, B1, C1	Relay output 1 (alarm output) 1 changeover contact output indicates that the inverter protective function has activated and the output stopped. Abnormal: No conduction across B-C (Across A-C Continuity), Normal: Across B-C Continuity (No conduction across A-C) Contact capacity: 230VAC 0.3A (Power factor = 0.4) 30VDC 0.3A	
		A2, B2, C2	Relay output 2 1 changeover contact output Contact capacity: 230VAC 0.3A (Power factor = 0.4) 30VDC 0.3A	
	Open collector	RUN	Inverter running	Switched low when the inverter output frequency is equal to or higher than the starting frequency (initial value 0.5Hz). Switched high during stop or DC injection brake operation. *
		SU	Up to frequency	Switched low when the output frequency reaches within the range of $\pm 10\%$ (initial value) of the set frequency. Switched high during acceleration/deceleration and at a stop. *
		OL	Overload warning	Switched low when stall prevention is activated by the stall prevention function. Switched high when stall prevention is cancelled. *
		IPF	Instantaneous power failure	Switched low when an instantaneous power failure and under voltage protections are activated. *
		FU	Frequency detection	Switched low when the inverter output frequency is equal to or higher than the preset detected frequency and high when less than the preset detected frequency. *
		SE	Open collector output common	Common terminal for terminals RUN, SU, OL, IPF, FU
	Pulse	FM	For meter	Select one e.g. output frequency from monitor items. (Not output during inverter reset.) The output signal is proportional to the magnitude of the corresponding monitoring item.
			NPN open collector output	
AM		Analog signal output	Output item: Output frequency (initial setting) Permissible load current 2mA 1440pulses/s at 60Hz Signals can be output from the open collector terminals by setting Pr. 29I. (Maximum output pulse: 50kpulses/s Permissible load current : 80mA)	
Communication	RS-485 terminals	—	PU connector With the PU connector, communication can be made through RS-485. (for connection on a 1:1 basis only) · Conforming standard : EIA-485 (RS-485) · Transmission format : Multidrop link · Communication speed : 4800 to 38400bps · Overall length : 500m	
		TXD+	Inverter transmission terminal	
		TXD-	Inverter reception terminal	
		RXD+	Inverter reception terminal	
		RXD-	Inverter reception terminal	
SG	Earth (Ground)			

**CAUTION**

- Set Pr. 73, Pr. 267, and a voltage/current input switch correctly, then input an analog signal in accordance with the setting.  
Applying a voltage signal with voltage/current input switch on (current input is selected) or a current signal with switch off (voltage input is selected) could cause component damage of the inverter or analog circuit of signal output devices.
- The inverter will be damaged if power is applied to the inverter output terminals (U, V, W). Never perform such wiring.
- indicates that terminal functions can be selected from Pr.178 to Pr.196 (I/O terminal function selection).
- Terminal names and terminal functions are those of the factory set.

Features  
Standard Specifications  
Outline Dimension Drawings  
Terminal Connection Diagram Terminal Specification Explanation  
Parameter List  
Protective Functions  
Options  
Instructions  
Warranty  
Inquiry

# Parameter List

For simple variable-speed operation of the inverter, the initial setting of the parameters may be used as they are. Set the necessary parameters to meet the load and operational specifications. Parameter setting, change and check can be made from the operation panel (FR-DU07).

### REMARKS

- ⊙ indicates simple mode parameters. (initially set to extended mode)
- The shaded parameters in the table allow its setting to be changed during operation even if "0" (initial value) is set in *Pr.77 Parameter write selection*.

Func tion	Parameter	Name	Setting Range	Minimum Setting Increment	Initial Value	Customer Setting	
Basic function	⊙ 0	Torque boost	0 to 30%	0.1%	3/2% *1		
	⊙ 1	Maximum frequency	0 to 120Hz	0.01Hz	120Hz		
	⊙ 2	Minimum frequency	0 to 120Hz	0.01Hz	0Hz		
	⊙ 3	Base frequency	0 to 400Hz	0.01Hz	60Hz		
	⊙ 4	Multi-speed setting (high speed)	0 to 400Hz	0.01Hz	60Hz		
	⊙ 5	Multi-speed setting (middle speed)	0 to 400Hz	0.01Hz	30Hz		
	⊙ 6	Multi-speed setting (low speed)	0 to 400Hz	0.01Hz	10Hz		
	⊙ 7	Acceleration time	0 to 3600/360s	0.1/0.01s	5/15s *1		
	⊙ 8	Deceleration time	0 to 3600/360s	0.1/0.01s	5/15s *1		
DC injection brake	10	DC injection brake operation frequency	0 to 120Hz, 9999	0.01Hz	3Hz		
	11	DC injection brake operation time	0 to 10s, 8888	0.1s	0.5s		
	12	DC injection brake operation voltage	0 to 30%	0.1%	4/2% *1		
—	13	Starting frequency	0 to 60Hz	0.01Hz	0.5Hz		
—	14	Load pattern selection	0 to 5	1	0		
Jog operation	15	Jog frequency	0 to 400Hz	0.01Hz	5Hz		
	16	Jog acceleration/deceleration time	0 to 3600/360s	0.1/0.01s	0.5s		
—	17	MRS input selection	0, 2, 4	1	0		
—	18	High speed maximum frequency	120 to 400Hz	0.01Hz	120Hz		
—	19	Base frequency voltage	0 to 1000V, 8888, 9999	0.1V	9999		
Acceleration/ deceleration time	20	Acceleration/deceleration reference frequency	1 to 400Hz	0.01Hz	60Hz		
	21	Acceleration/deceleration time increments	0, 1	1	0		
Stall prevention	22	Stall prevention operation level (torque limit level)	0 to 400%	0.1%	150%		
	23	Stall prevention operation level compensation factor at double speed	0 to 200%, 9999	0.1%	9999		
Multi-speed setting	24 to 27	Multi-speed setting (4 speed to 7 speed)	0 to 400Hz, 9999	0.01Hz	9999		
	—	28	Multi-speed input compensation selection	0, 1	1	0	
	—	29	Acceleration/deceleration pattern selection	0 to 5	1	0	
Frequency jump	31	Frequency jump 1A	0 to 400Hz, 9999	0.01Hz	9999		
	32	Frequency jump 1B	0 to 400Hz, 9999	0.01Hz	9999		
	33	Frequency jump 2A	0 to 400Hz, 9999	0.01Hz	9999		
	34	Frequency jump 2B	0 to 400Hz, 9999	0.01Hz	9999		
	35	Frequency jump 3A	0 to 400Hz, 9999	0.01Hz	9999		
	36	Frequency jump 3B	0 to 400Hz, 9999	0.01Hz	9999		
—	37	Speed display	0, 1 to 9998	1	0		
Frequency detection	41	Up-to-frequency sensitivity	0 to 100%	0.1%	10%		
	42	Output frequency detection	0 to 400Hz	0.01Hz	6Hz		
	43	Output frequency detection for reverse rotation	0 to 400Hz, 9999	0.01Hz	9999		

Function	Parameter	Name	Setting Range	Minimum Setting Increment	Initial Value	Customer Setting
Second function	44	Second acceleration/deceleration time	0 to 3600/360s	0.1/0.01s	5s	
	45	Second deceleration time	0 to 3600/360s, 9999	0.1/0.01s	9999	
	46	Second torque boost	0 to 30%, 9999	0.1%	9999	
	47	Second V/F (base frequency)	0 to 400Hz, 9999	0.01Hz	9999	
	48	Second stall prevention operation current	0 to 220%	0.1%	150%	
	49	Second stall prevention operation frequency	0 to 400Hz, 9999	0.01Hz	0Hz	
	50	Second output frequency detection	0 to 400Hz	0.01Hz	30Hz	
Monitor function	51	Second electronic thermal O/L relay	0 to 500A, 9999	0.01A	9999	
	52	DU/PU main display data selection	0, 5 to 8, 10 to 14, 17 to 20, 22 to 25, 32 to 35, 50 to 57, 65, 66, 100	1	0	
	54	FM terminal function selection	1 to 3, 5 to 8, 10 to 14, 17, 18, 21, 24, 32 to 34, 50, 52, 53	1	1	
	55	Frequency monitoring reference	0 to 400Hz	0.01Hz	60Hz	
Automatic restart	56	Current monitoring reference	0 to 500A	0.01A	Rated inverter current	
	57	Restart coasting time	0, 0.1 to 5s, 9999	0.1s	9999	
—	58	Restart cushion time	0 to 60s	0.1s	1s	
	59	Remote function selection	0, 1, 2, 3	1	0	
Automatic acceleration/ deceleration	60	Energy saving control selection	0, 4	1	0	
	61	Reference current	0 to 500A, 9999	0.01A	9999	
	62	Reference value at acceleration	0 to 220%, 9999	0.1%	9999	
	63	Reference value at deceleration	0 to 220%, 9999	0.1%	9999	
—	64	Starting frequency for elevator mode	0 to 10Hz, 9999	0.01Hz	9999	
	65	Retry selection	0 to 5	1	0	
Retry	66	Stall prevention operation reduction starting frequency	0 to 400Hz	0.01Hz	60Hz	
	67	Number of retries at fault occurrence	0 to 10, 101 to 110	1	0	
	68	Retry waiting time	0 to 10s	0.1s	1s	
Motor constants	69	Retry count display erase	0	1	0	
	71	Applied motor	0 to 8, 13 to 18, 30, 33, 34, 40, 43, 44, 50, 53, 54	1	0	
	72	PWM frequency selection	0 to 15	1	2	
	73	Analog input selection	0 to 7, 10 to 17	1	1	
	74	Input filter time constant	0 to 8	1	1	
	75	Reset selection/disconnected PU detection/PU stop selection	0 to 3, 14 to 17	1	14	
	76	Fault code output selection	0, 1, 2	1	0	
	77	Parameter write selection	0, 1, 2	1	0	
	78	Reverse rotation prevention selection	0, 1, 2	1	0	
	© 79	Operation mode selection	0, 1, 2, 3, 4, 6, 7	1	0	
—	80	Motor capacity	0.4 to 55kW, 9999	0.01kW	9999	
	81	Number of motor poles	2, 4, 6, 8, 10, 12, 14, 16, 18, 20, 9999	1	9999	
	82	Motor excitation current	0 to 500A, 9999	0.01A	9999	
	83	Rated motor voltage	0 to 1000V	0.1V	200V/400V *4	
	84	Rated motor frequency	10 to 120Hz	0.01Hz	60Hz	
	89	Speed control gain (advanced magnetic flux vector)	0 to 200%, 9999	0.1%	9999	
	90	Motor constant (R1)	0 to 50Ω, 9999	0.001Ω	9999	
	91	Motor constant (R2)	0 to 50Ω, 9999	0.001Ω	9999	
	92	Motor constant (L1)	0 to 50Ω(0 to 1000mH), 9999	0.001Ω (0.1mH)	9999	
	93	Motor constant (L2)	0 to 50Ω(0 to 1000mH), 9999	0.001Ω (0.1mH)	9999	
	94	Motor constant (X)	0 to 500Ω(0 to 100%), 9999	0.01Ω (0.1%)	9999	
95	Online auto tuning selection	0 to 2	1	0		
96	Auto tuning setting/status	0, 1, 101	1	0		

- Features
- Standard Specifications
- Outline Dimension Drawings
- Terminal Connection Diagram Terminal Specification Explanation
- Parameter List
- Protective Functions
- Options
- Instructions
- Warranty
- Inquiry

Function	Parameter	Name	Setting Range	Minimum Setting Increment	Initial Value	Customer Setting
Adjustable 5 points V/F	100	V/F1(first frequency)	0 to 400Hz, 9999	0.01Hz	9999	
	101	V/F1(first frequency voltage)	0 to 1000V	0.1V	0V	
	102	V/F2(second frequency)	0 to 400Hz, 9999	0.01Hz	9999	
	103	V/F2(second frequency voltage)	0 to 1000V	0.1V	0V	
	104	V/F3(third frequency)	0 to 400Hz, 9999	0.01Hz	9999	
	105	V/F3(third frequency voltage)	0 to 1000V	0.1V	0V	
	106	V/F4(fourth frequency)	0 to 400Hz, 9999	0.01Hz	9999	
	107	V/F4(fourth frequency voltage)	0 to 1000V	0.1V	0V	
	108	V/F5(fifth frequency)	0 to 400Hz, 9999	0.01Hz	9999	
Third function	109	V/F5(fifth frequency voltage)	0 to 1000V	0.1V	0V	
	110	Third acceleration/deceleration time	0 to 3600/360s, 9999	0.1/0.01s	9999	
	111	Third deceleration time	0 to 3600/360s, 9999	0.1/0.01s	9999	
	112	Third torque boost	0 to 30%, 9999	0.1%	9999	
	113	Third V/F (base frequency)	0 to 400Hz, 9999	0.01Hz	9999	
	114	Third stall prevention operation current	0 to 220%	0.1%	150%	
PU connector communication	115	Third stall prevention operation frequency	0 to 400Hz	0.01Hz	0	
	116	Third output frequency detection	0 to 400Hz	0.01Hz	60Hz	
	117	PU communication station number	0 to 31	1	0	
	118	PU communication speed	48, 96, 192, 384	1	192	
	119	PU communication stop bit length	0, 1, 10, 11	1	1	
	120	PU communication parity check	0, 1, 2	1	2	
	121	Number of PU communication retries	0 to 10, 9999	1	1	
	122	PU communication check time interval	0, 0.1 to 999.8s, 9999	0.1s	9999	
—	123	PU communication waiting time setting	0 to 150ms, 9999	1	9999	
	124	PU communication CR/LF selection	0, 1, 2	1	1	
—	⊙ 125	Terminal 2 frequency setting gain frequency	0 to 400Hz	0.01Hz	60Hz	
—	⊙ 126	Terminal 4 frequency setting gain frequency	0 to 400Hz	0.01Hz	60Hz	
PID operation	127	PID control automatic switchover frequency	0 to 400Hz, 9999	0.01Hz	9999	
	128	PID action selection	10, 11, 20, 21, 50, 51, 60, 61	1	10	
	129	PID proportional band	0.1 to 1000%, 9999	0.1%	100%	
	130	PID integral time	0.1 to 3600s, 9999	0.1s	1s	
	131	PID upper limit	0 to 100%, 9999	0.1%	9999	
	132	PID lower limit	0 to 100%, 9999	0.1%	9999	
	133	PID action set point	0 to 100%, 9999	0.01%	9999	
Bypass	134	PID differential time	0.01 to 10.00s, 9999	0.01s	9999	
	135	Electronic bypass sequence selection	0, 1	1	0	
	136	MC switchover interlock time	0 to 100s	0.1s	1s	
	137	Start waiting time	0 to 100s	0.1s	0.5s	
	138	Bypass selection at a fault	0, 1	1	0	
Backlash measures	139	Automatic switchover frequency from inverter to bypass operation	0 to 60Hz, 9999	0.01Hz	9999	
	140	Backlash acceleration stopping frequency	0 to 400Hz	0.01Hz	1Hz	
	141	Backlash acceleration stopping time	0 to 360s	0.1s	0.5s	
	142	Backlash deceleration stopping frequency	0 to 400Hz	0.01Hz	1Hz	
—	143	Backlash deceleration stopping time	0 to 360s	0.1s	0.5s	
—	144	Speed setting switchover	0, 2, 4, 6, 8, 10, 102, 104, 106, 108, 110	1	4	
PU	145	PU display language selection	0 to 7	1	0	
Current detection	148	Stall prevention level at 0V input	0 to 220%	0.1%	150%	
	149	Stall prevention level at 10V input	0 to 220%	0.1%	200%	
	150	Output current detection level	0 to 220%	0.1%	150%	
	151	Output current detection signal delay time	0 to 10s	0.1s	0s	
	152	Zero current detection level	0 to 220%	0.1%	5%	
—	153	Zero current detection time	0 to 1s	0.01s	0.5s	
—	154	Voltage reduction selection during stall prevention operation	0, 1	1	1	
—	155	RT signal function validity condition selection	0, 10	1	0	
—	156	Stall prevention operation selection	0 to 31, 100, 101	1	0	
—	157	OL signal output timer	0 to 25s, 9999	0.1s	0s	

Function	Parameter	Name	Setting Range	Minimum Setting Increment	Initial Value	Customer Setting
—	<b>158</b>	AM terminal function selection	1 to 3, 5 to 8, 10 to 14, 17, 18, 21, 24, 32 to 34, 50, 52, 53	1	1	
—	<b>159</b>	Automatic switchover frequency range from bypass to inverter operation	0 to 10Hz, 9999	0.01Hz	9999	
—	Ⓢ <b>160</b>	User group read selection	0, 1, 9999	1	0	
—	<b>161</b>	Frequency setting/key lock operation selection	0, 1, 10, 11	1	0	
Automatic restart function	<b>162</b>	Automatic restart after instantaneous power failure selection	0, 1, 2, 10, 11, 12	1	0	
	<b>163</b>	First cushion time for restart	0 to 20s	0.1s	0s	
	<b>164</b>	First cushion voltage for restart	0 to 100%	0.1%	0%	
	<b>165</b>	Stall prevention operation level for restart	0 to 220%	0.1%	150%	
Current detection	<b>166</b>	Output current detection signal retention time	0 to 10s, 9999	0.1s	0.1s	
	<b>167</b>	Output current detection operation selection	0, 1	1	0	
—	<b>168</b>	Parameter for manufacturer setting. Do not set.				
—	<b>169</b>					
Cumulative monitor clear	<b>170</b>	Watt-hour meter clear	0, 2, 10, 9999	1	9999	
	<b>171</b>	Operation hour meter clear	0, 9999	1	9999	
User group	<b>172</b>	User group registered display/batch clear	9999, (0 to 16)	1	0	
	<b>173</b>	User group registration	0 to 999, 9999	1	9999	
	<b>174</b>	User group clear	0 to 999, 9999	1	9999	
Input terminal function assignment	<b>178</b>	STF terminal function selection	0 to 9, 12 to 20, 22 to 28, 42 to 44, 60, 62, 64 to 69, 74, 9999	1	60	
	<b>179</b>	STR terminal function selection	0 to 9, 12 to 20, 22 to 28, 42 to 44, 61, 62, 64 to 69, 74, 9999	1	61	
	<b>180</b>	RL terminal function selection	0 to 9, 12 to 20, 22 to 28, 42 to 44, 62, 64 to 69, 74, 9999	1	0	
	<b>181</b>	RM terminal function selection		1	1	
	<b>182</b>	RH terminal function selection		1	2	
	<b>183</b>	RT terminal function selection		1	3	
	<b>184</b>	AU terminal function selection	0 to 9, 12 to 20, 22 to 28, 42 to 44, 62 to 69, 74, 9999	1	4	
	<b>185</b>	JOG terminal function selection	0 to 9, 12 to 20, 22 to 28, 42 to 44, 62, 64 to 69, 74, 9999	1	5	
	<b>186</b>	CS terminal function selection		1	6	
	<b>187</b>	MRS terminal function selection		1	24	
<b>188</b>	STOP terminal function selection	1		25		
<b>189</b>	RES terminal function selection	1		62		
Output terminal function assignment	<b>190</b>	RUN terminal function selection	0 to 6, 8, 10 to 20, 25 to 28, 30 to 36, 39, 41 to 47, 64, 70, 84, 90 to 99, 100 to 106, 108, 110 to 116, 120, 125 to 128, 130 to 136, 139, 141 to 147, 164, 170, 184, 190 to 199, 9999	1	0	
	<b>191</b>	SU terminal function selection	0 to 6, 8, 10 to 20, 25 to 28, 30 to 36, 39, 41 to 47, 64, 70, 84, 90, 91, 94 to 99, 100 to 106, 108, 110 to 116, 120, 125 to 128, 130 to 136, 139, 141 to 147, 164, 170, 184, 190, 191, 194 to 199, 9999	1	1	
	<b>192</b>	IPF terminal function selection		1	2	
	<b>193</b>	OL terminal function selection		1	3	
	<b>194</b>	FU terminal function selection		1	4	
	<b>195</b>	ABC1 terminal function selection	0 to 6, 8, 10 to 20, 25 to 28, 30 to 36, 39, 41 to 47, 64, 70, 84, 90, 91, 94 to 99, 100 to 106, 108, 110 to 116, 120, 125 to 128, 130 to 136, 139, 141 to 147, 164, 170, 184, 190, 191, 194 to 199, 9999	1	99	
	<b>196</b>	ABC2 terminal function selection		1	9999	

- Features
- Standard Specifications
- Outline Dimension Drawings
- Terminal Connection Diagram, Terminal Specification Explanation
- Parameter List
- Protective Functions
- Options
- Instructions
- Warranty
- Inquiry



Function	Parameter	Name	Setting Range	Minimum Setting Increment	Initial Value	Customer Setting	
Multi-speed setting	232 to 239	Multi-speed setting (8 speed to 15 speed)	0 to 400Hz, 9999	0.01Hz	9999		
	—	240	Soft-PWM operation selection	0, 1	1	1	
—	241	Analog input display unit switchover	0, 1	1	0		
—	242	Terminal 1 added compensation amount (terminal 2)	0 to 100%	0.1%	100%		
—	243	Terminal 1 added compensation amount (terminal 4)	0 to 100%	0.1%	75%		
—	244	Cooling fan operation selection	0, 1	1	1		
Slip compensation	245	Rated slip	0 to 50%, 9999	0.01%	9999		
	246	Slip compensation time constant	0.01 to 10s	0.01s	0.5s		
	247	Constant-power range slip compensation selection	0, 9999	1	9999		
—	250	Stop selection	0 to 100s, 1000 to 1100s, 8888, 9999	0.1s	9999		
—	251	Output phase loss protection selection	0, 1	1	1		
Frequency compensation function	252	Override bias	0 to 200%	0.1%	50%		
	253	Override gain	0 to 200%	0.1%	150%		
Life check	255	Life alarm status display	(0 to 15)	1	0		
	256	Inrush current limit circuit life display	(0 to 100%)	1%	100%		
	257	Control circuit capacitor life display	(0 to 100%)	1%	100%		
	258	Main circuit capacitor life display	(0 to 100%)	1%	100%		
	259	Main circuit capacitor life measuring	0, 1	1	0		
Power failure stop	261	Power failure stop selection	0, 1, 2, 11, 12	1	0		
	262	Subtracted frequency at deceleration start	0 to 20Hz	0.01Hz	3Hz		
	263	Subtraction starting frequency	0 to 120Hz, 9999	0.01Hz	60Hz		
	264	Power-failure deceleration time 1	0 to 3600/ 360s	0.1/0.01s	5s		
	265	Power-failure deceleration time 2	0 to 3600/ 360s, 9999	0.1/0.01s	9999		
	266	Power failure deceleration time switchover frequency	0 to 400Hz	0.01Hz	60Hz		
—	267	Terminal 4 input selection	0, 1, 2	1	0		
—	268	Monitor decimal digits selection	0, 1, 9999	1	9999		
—	269	Parameter for manufacturer setting. Do not set.					
—	270	Stop-on contact/load torque high-speed frequency control selection	0, 1, 2, 3	1	0		
Load torque high speed frequency control	271	High-speed setting maximum current	0 to 220%	0.1%	50%		
	272	Middle-speed setting minimum current	0 to 220%	0.1%	100%		
	273	Current averaging range	0 to 400Hz, 9999	0.01Hz	9999		
	274	Current averaging filter time constant	1 to 4000	1	16		
Stop-on contact control	275	Stop-on contact excitation current low-speed multiplying factor	0 to 1000%, 9999	0.1%	9999		
	276	PWM carrier frequency at stop-on contact	0 to 9, 9999	1	9999		

Function	Parameter	Name	Setting Range	Minimum Setting Increment	Initial Value	Customer Setting
Brake sequence function	278	Brake opening frequency	0 to 30Hz	0.01Hz	3Hz	
	279	Brake opening current	0 to 220%	0.1%	130%	
	280	Brake opening current detection time	0 to 2s	0.1s	0.3s	
	281	Brake operation time at start	0 to 5s	0.1s	0.3s	
	282	Brake operation frequency	0 to 30Hz	0.01Hz	6Hz	
	283	Brake operation time at stop	0 to 5s	0.1s	0.3s	
	284	Deceleration detection function selection	0, 1	1	0	
Droop control	285	Overspeed detection frequency (Speed deviation excess detection frequency)	0 to 30Hz, 9999	0.01Hz	9999	
	286	Droop gain	0 to 100%	0.1%	0%	
	287	Droop filter time constant	0 to 1s	0.01s	0.3s	
—	288	Droop function activation selection	0, 1, 2, 10, 11	1	0	
	291	Pulse train I/O selection	0, 1, 10, 11, 20, 21, 100	1	0	
—	292	Automatic acceleration/deceleration	0, 3, 5 to 8, 11	1	0	
	293	Acceleration/deceleration separate selection	0 to 2	1	0	
	294	UV avoidance voltage gain	0 to 200%	0.1%	100%	
Password function	296	Password lock level	0 to 6, 99, 100 to 106, 199, 9999	1	9999	
	297	Password lock/unlock	(0 to 5), 1000 to 9998, 9999	1	9999	
—	299	Rotation direction detection selection at restarting	0, 1, 9999	1	0	
RS-485 communication	331	RS-485 communication station number	0 to 31(0 to 247)	1	0	
	332	RS-485 communication speed	3, 6, 12, 24, 48, 96, 192, 384	1	96	
	333	RS-485 communication stop bit length	0, 1, 10, 11	1	1	
	334	RS-485 communication parity check selection	0, 1, 2	1	2	
	335	RS-485 communication retry count	0 to 10, 9999	1	1	
	336	RS-485 communication check time interval	0 to 999.8s, 9999	0.1s	0s	
	337	RS-485 communication waiting time setting	0 to 150ms, 9999	1	9999	
	338	Communication operation command source	0, 1	1	0	
	339	Communication speed command source	0, 1, 2	1	0	
	340	Communication startup mode selection	0, 1, 2, 10, 12	1	0	
	341	RS-485 communication CR/LF selection	0, 1, 2	1	1	
Orientation control	342	Communication EEPROM write selection	0, 1	1	0	
	343	Communication error count	—	1	0	
	350 *2	Stop position command selection	0, 1, 9999	1	9999	
	351 *2	Orientation speed	0 to 30Hz	0.01Hz	2Hz	
	352 *2	Creep speed	0 to 10Hz	0.01Hz	0.5Hz	
	353 *2	Creep switchover position	0 to 16383	1	511	
	354 *2	Position loop switchover position	0 to 8191	1	96	
	355 *2	DC injection brake start position	0 to 255	1	5	
	356 *2	Internal stop position command	0 to 16383	1	0	
	357 *2	Orientation in-position zone	0 to 255	1	5	
	358 *2	Servo torque selection	0 to 13	1	1	
	359 *2	Encoder rotation direction	0, 1	1	1	
	360 *2	16 bit data selection	0 to 127	1	0	
Encoder feedback	361 *2	Position shift	0 to 16383	1	0	
	362 *2	Orientation position loop gain	0.1 to 100	0.1	1	
	363 *2	Completion signal output delay time	0 to 5s	0.1s	0.5s	
	364 *2	Encoder stop check time	0 to 5s	0.1s	0.5s	
	365 *2	Orientation limit	0 to 60s, 9999	1s	9999	
	366 *2	Recheck time	0 to 5s, 9999	0.1s	9999	
	367 *2	Speed feedback range	0 to 400Hz, 9999	0.01Hz	9999	
	368 *2	Feedback gain	0 to 100	0.1	1	
—	369 *2	Number of encoder pulses	0 to 4096	1	1024	
	374	Overspeed detection level	0 to 400Hz	0.01Hz	140Hz	
—	376 *2	Encoder signal loss detection enable/disable selection	0, 1	1	0	

Features
Standard Specifications
Outline Dimension Drawings
Terminal Connection Diagram, Terminal Specification Explanation
Parameter List
Protective Functions
Options
Instructions
Warranty
Inquiry

Function	Parameter	Name	Setting Range	Minimum Setting Increment	Initial Value	Customer Setting
S-pattern acceleration/deceleration C	380	Acceleration S-pattern 1	0 to 50%	1%	0	
	381	Deceleration S-pattern 1	0 to 50%	1%	0	
	382	Acceleration S-pattern 2	0 to 50%	1%	0	
	383	Deceleration S-pattern 2	0 to 50%	1%	0	
Pulse train input	384	Input pulse division scaling factor	0 to 250	1	0	
	385	Frequency for zero input pulse	0 to 400Hz	0.01Hz	0	
	386	Frequency for maximum input pulse	0 to 400Hz	0.01Hz	60Hz	
Orientation control	393 *2	Orientation selection	0, 1, 2	1	0	
	396 *2	Orientation speed gain (P term)	0 to 1000	1	60	
	397 *2	Orientation speed integral time	0 to 20.0s	0.001s	0.333s	
	398 *2	Orientation speed gain (D term)	0 to 100.0%	0.1%	1%	
	399 *2	Orientation deceleration ratio	0 to 1000	1	20	
Position control	419 *2	Position command source selection	0 to 2	1	0	
	420 *2	Command pulse scaling factor numerator	0 to 32767	1	1	
	421 *2	Command pulse scaling factor denominator	0 to 32767	1	1	
	422 *2	Position loop gain	0 to 150sec <sup>-1</sup>	1sec <sup>-1</sup>	25sec <sup>-1</sup>	
	423 *2	Position feed forward gain	0 to 100%	1%	0%	
	424 *2	Position command acceleration/deceleration time constant	0 to 50s	0.001s	0s	
	425 *2	Position feed forward command filter	0 to 5s	0.001s	0s	
	426 *2	In-position width	0 to 32767pulse	1pulse	100pulse	
	427 *2	Excessive level error	0 to 400K, 9999	1K	40K	
	428 *2	Command pulse selection	0 to 5	1	0	
	429 *2	Clear signal selection	0, 1	1	1	
430 *2	Pulse monitor selection	0 to 5, 9999	1	9999		
Second motor constants	450	Second applied motor	0 to 8, 13 to 18, 30, 33, 34, 40, 43, 44, 50, 53, 54, 9999	1	9999	
	451	Second motor control method selection	10, 11, 12, 20, 9999	1	9999	
	453	Second motor capacity	0.4 to 55kW, 9999	0.01kW	9999	
	454	Number of second motor poles	2, 4, 6, 8, 10, 9999	1	9999	
	455	Second motor excitation current	0 to 500A, 9999	0.01A	9999	
	456	Rated second motor voltage	0 to 1000V	0.1V	200V/400V *4	
	457	Rated second motor frequency	10 to 120Hz	0.01Hz	60Hz	
	458	Second motor constant (R1)	0 to 50Ω, 9999	0.001Ω	9999	
	459	Second motor constant (R2)	0 to 50Ω, 9999	0.001Ω	9999	
	460	Second motor constant (L1)	0 to 50Ω (0 to 1000mH), 9999	0.001Ω (0.1mH)	9999	
	461	Second motor constant (L2)	0 to 50Ω (0 to 1000mH), 9999	0.001Ω (0.1mH)	9999	
	462	Second motor constant (X)	0 to 500Ω (0 to 100%), 9999	0.01Ω (0.1%)	9999	
	463	Second motor auto tuning setting/status	0, 1, 101	1	0	

Function	Parameter	Name	Setting Range	Minimum Setting Increment	Initial Value	Customer Setting
Simple position feed function	464 *2	Digital position control sudden stop deceleration time	0 to 360.0s	0.1s	0	
	465 *2	First position feed amount lower 4 digits	0 to 9999	1	0	
	466 *2	First position feed amount upper 4 digits	0 to 9999	1	0	
	467 *2	Second position feed amount lower 4 digits	0 to 9999	1	0	
	468 *2	Second position feed amount upper 4 digits	0 to 9999	1	0	
	469 *2	Third position feed amount lower 4 digits	0 to 9999	1	0	
	470 *2	Third position feed amount upper 4 digits	0 to 9999	1	0	
	471 *2	Fourth position feed amount lower 4 digits	0 to 9999	1	0	
	472 *2	Fourth position feed amount lower 4 digits	0 to 9999	1	0	
	473 *2	Fifth position feed amount lower 4 digits	0 to 9999	1	0	
	474 *2	Fifth position feed amount upper 4 digits	0 to 9999	1	0	
	475 *2	Sixth position feed amount lower 4 digits	0 to 9999	1	0	
	476 *2	Sixth position feed amount upper 4 digits	0 to 9999	1	0	
	477 *2	Seventh position feed amount lower 4 digits	0 to 9999	1	0	
	478 *2	Seventh position feed amount upper 4 digits	0 to 9999	1	0	
	479 *2	Eighth position feed amount lower 4 digits	0 to 9999	1	0	
	480 *2	Eighth position feed amount upper 4 digits	0 to 9999	1	0	
	481 *2	Ninth position feed amount lower 4 digits	0 to 9999	1	0	
	482 *2	Ninth position feed amount upper 4 digits	0 to 9999	1	0	
	483 *2	Tenth position feed amount lower 4 digits	0 to 9999	1	0	
	484 *2	Tenth position feed amount upper 4 digits	0 to 9999	1	0	
	485 *2	Eleventh position feed amount lower 4 digits	0 to 9999	1	0	
	486 *2	Eleventh position feed amount upper 4 digits	0 to 9999	1	0	
	487 *2	Twelfth position feed amount lower 4 digits	0 to 9999	1	0	
488 *2	Twelfth position feed amount upper 4 digits	0 to 9999	1	0		
489 *2	Thirteenth position feed amount lower 4 digits	0 to 9999	1	0		
490 *2	Thirteenth position feed amount upper 4 digits	0 to 9999	1	0		
491 *2	Fourteenth position feed amount lower 4 digits	0 to 9999	1	0		
492 *2	Fourteenth position feed amount upper 4 digits	0 to 9999	1	0		
493 *2	Fifteenth position feed amount lower 4 digits	0 to 9999	1	0		
494 *2	Fifteenth position feed amount upper 4 digits	0 to 9999	1	0		
Remote output	495	Remote output selection	0, 1, 10, 11	1	0	
	496	Remote output data 1	0 to 4095	1	0	
	497	Remote output data 2	0 to 4095	1	0	
Maintenance	503	Maintenance timer	0(1 to 9998)	1	0	
	504	Maintenance timer alarm output set time	0 to 9998, 9999	1	9999	
—	505	Speed setting reference	1 to 120Hz	0.01Hz	60Hz	
S-pattern acceleration/ deceleration D	516	S-pattern time at a start of acceleration	0.1 to 2.5s	0.1s	0.1s	
	517	S-pattern time at a completion of acceleration	0.1 to 2.5s	0.1s	0.1s	
	518	S-pattern time at a start of deceleration	0.1 to 2.5s	0.1s	0.1s	
	519	S-pattern time at a completion of deceleration	0.1 to 2.5s	0.1s	0.1s	
—	539	Modbus-RTU communication check time interval	0 to 999.8s, 9999	0.1s	9999	
—	547	Parameter for manufacturer setting. Do not set.				
	548					
Communication	549	Protocol selection	0, 1	1	0	
	550	NET mode operation command source selection	0, 1, 9999	1	9999	
	551	PU mode operation command source selection	1, 2, 3	1	2	

- Features
- Standard Specifications
- Outline Dimension Drawings
- Terminal Connection Diagram, Terminal Specification Explanation
- Parameter List
- Protective Functions
- Options
- Instructions
- Warranty
- Inquiry

Function	Parameter	Name	Setting Range	Minimum Setting Increment	Initial Value	Customer Setting
Current average value monitor	555	Current average time	0.1 to 1.0s	0.1s	1s	
	556	Data output mask time	0.0 to 20.0s	0.1s	0s	
	557	Current average value monitor signal output reference current	0 to 500A	0.01A	Rated inverter current	
—	563	Energization time carrying-over times	(0 to 65535)	1	0	
—	564	Operating time carrying-over times	(0 to 65535)	1	0	
Second motor constants	569	Second motor speed control gain	0 to 200%, 9999	0.1%	9999	
	571	Holding time at a start	0.0 to 10.0s, 9999	0.1s	9999	
	574	Second motor online auto tuning	0, 1	1	0	
PID control	575	Output interruption detection time	0 to 3600s, 9999	0.1s	1s	
	576	Output interruption detection level	0 to 400Hz	0.01Hz	0Hz	
	577	Output interruption cancel level	900 to 1100%	0.1%	1000%	
—	611	Acceleration time at a restart	0 to 3600s,9999	0.1s	5s	
—	665	Regeneration avoidance frequency gain	0 to 200%	0.1%	100%	
—	684	Tuning data unit switchover	0, 1	1	0	
—	800	Control method selection	0 to 5, 9 to 12, 20	1	20	
—	802 *2	Pre-excitation selection	0, 1	1	0	
Torque command	803	Constant power range torque characteristic selection	0, 1	1	0	
	804	Torque command source selection	0 to 6	1	0	
	805	Torque command value (RAM)	600 to 1400%	1%	1000%	
	806	Torque command value (RAM,EEPROM)	600 to 1400%	1%	1000%	
Speed limit	807	Speed limit selection	0, 1, 2	1	0	
	808	Forward rotation speed limit	0 to 120Hz	0.01Hz	60Hz	
	809	Reverse rotation speed limit	0 to 120Hz, 9999	0.01Hz	9999	
Torque limit	810	Torque limit input method selection	0, 1	1	0	
	811	Set resolution switchover	0, 1, 10, 11	1	0	
	812	Torque limit level (regeneration)	0 to 400%, 9999	0.1%	9999	
	813	Torque limit level (3rd quadrant)	0 to 400%, 9999	0.1%	9999	
	814	Torque limit level (4th quadrant)	0 to 400%, 9999	0.1%	9999	
	815	Torque limit level 2	0 to 400%, 9999	0.1%	9999	
	816	Torque limit level during acceleration	0 to 400%, 9999	0.1%	9999	
Easy gain tuning	817	Torque limit level during deceleration	0 to 400%, 9999	0.1%	9999	
	818	Easy gain tuning response level setting	1 to 15	1	2	
Adjustment function	819	Easy gain tuning selection	0 to 2	1	0	
	820	Speed control P gain 1	0 to 1000%	1%	60%	
	821	Speed control integral time 1	0 to 20s	0.001s	0.333s	
	822	Speed setting filter 1	0 to 5s, 9999	0.001s	9999	
	823 *2	Speed detection filter 1	0 to 0.1s	0.001s	0.001s	
	824	Torque control P gain 1	0 to 200%	1%	100%	
	825	Torque control integral time 1	0 to 500ms	0.1ms	5ms	
	826	Torque setting filter 1	0 to 5s, 9999	0.001s	9999	
	827	Torque detection filter 1	0 to 0.1s	0.001s	0s	
	828	Model speed control gain	0 to 1000%	1%	60%	
	830	Speed control P gain 2	0 to 1000%, 9999	1%	9999	
	831	Speed control integral time 2	0 to 20s, 9999	0.001s	9999	
	832	Speed setting filter 2	0 to 5s, 9999	0.001s	9999	
	833 *2	Speed detection filter 2	0 to 0.1s, 9999	0.001s	9999	
	834	Torque control P gain 2	0 to 200%, 9999	1%	9999	
	835	Torque control integral time 2	0 to 500ms, 9999	0.1ms	9999	
	836	Torque setting filter 2	0 to 5s, 9999	0.001s	9999	
837	Torque detection filter 2	0 to 0.1s, 9999	0.001s	9999		

Function	Parameter	Name	Setting Range	Minimum Setting Increment	Initial Value	Customer Setting
Torque bias	840 *2	Torque bias selection	0 to 3, 9999	1	9999	
	841 *2	Torque bias 1	600 to 1400%, 9999	1%	9999	
	842 *2	Torque bias 2	600 to 1400%, 9999	1%	9999	
	843 *2	Torque bias 3	600 to 1400%, 9999	1%	9999	
	844 *2	Torque bias filter	0 to 5s, 9999	0.001s	9999	
	845 *2	Torque bias operation time	0 to 5s, 9999	0.01s	9999	
	846 *2	Torque bias balance compensation	0 to 10V, 9999	0.1V	9999	
	847 *2	Fall-time torque bias terminal 1 bias	0 to 400%, 9999	1%	9999	
Additional function	848 *2	Fall-time torque bias terminal 1 gain	0 to 400%, 9999	1%	9999	
	849	Analog input offset adjustment	0 to 200%	0.1%	100%	
	850	Brake operation selection	0 to 2	1	0	
	853 *2	Speed deviation time	0 to 100s	0.1s	1s	
	854	Excitation ratio	0 to 100%	1%	100%	
	858	Terminal 4 function assignment	0, 1, 4, 9999	1	0	
	859	Torque current	0 to 500A, 9999	0.01A	9999	
	860	Second motor torque current	0 to 500A, 9999	0.01A	9999	
	862	Notch filter time constant	0 to 60	1	0	
	863	Notch filter depth	0, 1, 2, 3	1	0	
Indication function	864	Torque detection	0 to 400%	0.1%	150%	
	865	Low speed detection	0 to 400Hz	0.01Hz	1.5Hz	
—	866	Torque monitoring reference	0 to 400%	0.1%	150%	
—	867	AM output filter	0 to 5s	0.01s	0.01s	
—	868	Terminal 1 function assignment	0 to 6, 9999	1	0	
Protective Functions	872	Input phase loss protection selection	0, 1	1	1	
	873 *2	Speed limit	0 to 120Hz	0.01Hz	20Hz	
	874	OLT level setting	0 to 200%	0.1%	150%	
	875	Fault definition	0, 1	1	0	
Control system functions	877	Speed feed forward control/model adaptive speed control selection	0, 1, 2	1	0	
	878	Speed feed forward filter	0 to 1s	0.01s	0s	
	879	Speed feed forward torque limit	0 to 400%	0.1%	150%	
	880	Load inertia ratio	0 to 200 times	0.1	7	
	881	Speed feed forward gain	0 to 1000%	1%	0%	
Regeneration avoidance function	882	Regeneration avoidance operation selection	0, 1, 2	1	0	
	883	Regeneration avoidance operation level	300 to 800V	0.1V	DC380V/ DC760V *4	
	884	Regeneration avoidance at deceleration detection sensitivity	0 to 5	1	0	
	885	Regeneration avoidance compensation frequency limit value	0 to 10Hz, 9999	0.01Hz	6Hz	
Free parameter	886	Regeneration avoidance voltage gain	0 to 200%	0.1%	100%	
	888	Free parameter 1	0 to 9999	1	9999	
Energy saving monitor	889	Free parameter 2	0 to 9999	1	9999	
	891	Cumulative power monitor digit shifted times	0 to 4, 9999	1	9999	
	892	Load factor	30 to 150%	0.1%	100%	
	893	Energy saving monitor reference (motor capacity)	0.1 to 55kW	0.01kW	Inverter rated capacity	
	894	Control selection during commercial power-supply operation	0, 1, 2, 3	1	0	
	895	Power saving rate reference value	0, 1, 9999	1	9999	
	896	Power unit cost	0 to 500, 9999	0.01	9999	
	897	Power saving monitor average time	0, 1 to 1000h, 9999	1h	9999	
	898	Power saving cumulative monitor clear	0, 1, 10, 9999	1	9999	
899	Operation time rate (estimated value)	0 to 100%, 9999	0.1%	9999		

Features
Standard Specifications
Outline Dimension Drawings
Terminal Connection Diagram Terminal Specification Explanation
Parameter List
Protective Functions
Options
Instructions
Warranty
Inquiry

Function	Parameter	Name	Setting Range	Minimum Setting Increment	Initial Value	Customer Setting
Calibration parameters	C0 (900)*3	FM terminal calibration	—	—	—	
	C1 (901)*3	AM terminal calibration	—	—	—	
	C2 (902)*3	Terminal 2 frequency setting bias frequency	0 to 400Hz	0.01Hz	0Hz	
	C3 (902)*3	Terminal 2 frequency setting bias	0 to 300%	0.1%	0%	
	125 (903)*3	Terminal 2 frequency setting gain frequency	0 to 400Hz	0.01Hz	60Hz	
	C4 (903)*3	Terminal 2 frequency setting gain	0 to 300%	0.1%	100%	
	C5 (904)*3	Terminal 4 frequency setting bias frequency	0 to 400Hz	0.01Hz	0Hz	
	C6 (904)*3	Terminal 4 frequency setting bias	0 to 300%	0.1%	20%	
	126 (905)*3	Terminal 4 frequency setting gain frequency	0 to 400Hz	0.01Hz	60Hz	
	C7 (905)*3	Terminal 4 frequency setting gain	0 to 300%	0.1%	100%	
	C12 (917)*3	Terminal 1 bias frequency (speed)	0 to 400Hz	0.01Hz	0Hz	
	C13 (917)*3	Terminal 1 bias (speed)	0 to 300%	0.1%	0%	
	C14 (918)*3	Terminal 1 gain frequency (speed)	0 to 400Hz	0.01Hz	60Hz	
	C15 (918)*3	Terminal 1 gain (speed)	0 to 300%	0.1%	100%	
	C16 (919)*3	Terminal 1 bias command (torque/magnetic flux)	0 to 400%	0.1%	0%	
	C17 (919)*3	Terminal 1 bias (torque/magnetic flux)	0 to 300%	0.1%	0%	
	C18 (920)*3	Terminal 1 gain command (torque/magnetic flux)	0 to 400%	0.1%	150%	
	C19 (920)*3	Terminal 1 gain (torque/magnetic flux)	0 to 300%	0.1%	100%	
	C38 (932)*3	Terminal 4 bias command (torque/magnetic flux)	0 to 400%	0.1%	0%	
	C39 (932)*3	Terminal 4 bias (torque/magnetic flux)	0 to 300%	0.1%	20%	
	C40 (933)*3	Terminal 4 gain command (torque/magnetic flux)	0 to 400%	0.1%	150%	
C41 (933)*3	Terminal 4 gain (torque/magnetic flux)	0 to 300%	0.1%	100%		
—	989	Parameter for manufacturer setting. Do not set.				
PU	990	PU buzzer control	0, 1	1	1	
	991	PU contrast adjustment	0 to 63	1	58	
Clear parameter	Pr.CL	Parameter clear	0, 1	1	0	
	ALLC	All parameter clear	0, 1	1	0	
	Er.CL	Faults history clear	0, 1	1	0	
	PCPY	Parameter copy	0, 1, 2, 3	1	0	

\*1 Differ according to capacities. (7.5K or lower/11K or higher)

\*2 Setting can be made only when the FR-A7AP/FR-A7AL is mounted.

\*3 The parameter number in parentheses is the one for use with the parameter unit (FR-PU07/FR-PU04).

\*4 Differs according to the voltage class. (200V class/400V class)

# Protective Functions

When a fault occurs in the inverter, the inverter trips and the PU display automatically changes to one of the following fault or alarm indications.

	Function Name	Description	Display
Error Message *2	Operation panel lock	Appears when operation is attempted during operation panel lock.	HOLD
	Password locked	Password function is active. Display and setting of parameters are restricted.	LOCd
	Parameter write error	Appears when an error occurs during parameter writing.	Er 1 to Er 4
	Copy operation error	Appears when an error occurs during parameter copying.	rEr 1 to rEr 4
	Error	Appears when the RES signal is on or the PU and inverter cannot communicate normally.	Err.
Warning *3	Stall prevention (overcurrent)	Appears during overcurrent stall prevention.	OL
	Stall prevention (overvoltage)	Appears during overvoltage stall prevention. Appears while the regeneration avoidance function is activated.	oL
	Electronic thermal relay function prealarm	Appears when the electronic thermal O/L relay reaches 85% of the specified value.	TH
	PU stop	Appears when  on the operation panel is pressed during external operation.	PS
	Maintenance signal output *8	Appears when the cumulative energization time exceeds the maintenance output timer set value.	MF
	Parameter copy	Appears when parameters are copied between the FR-A701 series and FR-A700 series 75K or higher.	CP
	Speed limit display (output during speed limit)	Appears if the speed limit level is exceeded during torque control.	SL
Alarm *4	Fan fault	Appears when the cooling fan remains stopped when operation is required or when the speed decreases.	F <sub>n</sub>
Fault *5	Overcurrent trip during acceleration	Appears when an overcurrent occurs during acceleration.	EOC 1
	Overcurrent trip during constant speed	Appears when an overcurrent occurs during constant speed operation.	EOC 2
	Overcurrent trip during deceleration or stop	Appears when an overcurrent occurs during deceleration or at a stop.	EOC 3
	Regenerative overvoltage trip during acceleration	Appears when an overvoltage occurs during acceleration.	EOV 1 EOV 2 EOV 3
	Regenerative overvoltage trip during constant speed	Appears when an overvoltage occurs during constant speed operation.	
	Regenerative overvoltage trip during deceleration or stop	Appears when an overvoltage occurs during deceleration or at a stop.	
	Inverter overload trip (electronic thermal relay function) *1	Appears when the electronic thermal relay function for inverter element protection is activated.	EFHF
	Motor overload trip (electronic thermal relay function) *1	Appears when the electronic thermal relay function for motor protection is activated.	EFHM
	Fin overheat	Appears when the heatsink overheats.	EFIn
	Instantaneous power failure protection	Appears when an instantaneous power failure occurs at an input power supply.	EIPF
	Undervoltage	Appears when the main circuit DC voltage becomes too low.	EUUF
	Input phase loss	Appears if one of the three phases on the inverter input side opens.	EILF
	Stall prevention stop	Appears when the output frequency drops to 0.5Hz as a result of deceleration due to the excess motor load.	EOLr
	Output side earth (ground) fault overcurrent	Appears when an earth (ground) fault occurs on the inverter's output side.	E.GF
	Output phase loss	Appears if one of the three phases on the inverter output side opens.	E.LF
	External thermal relay operation *6 *8	Appears when the external thermal relay connected to the terminal OH is activated.	EOHF
PTC thermistor operation *8	Appears when the motor overheat status is detected for 10s or more by the external PTC thermistor input connected to the terminal AU.	EPFC	
Option fault	Appears when torque command by the plug-in option is selected using Pr.804 and no plug-in option is mounted. This function is available under torque control. Appears when a communication option is connected while Pr. 296 = "0 or 100."	EOPI	
Communication option fault	Appears when a communication line error occurs in the communication option.	EOP3	

- Features
- Standard Specifications
- Outline Dimension Drawings
- Terminal Connection Diagram, Terminal Specification Explanation
- Parameter List
- Protective Functions
- Options
- Instructions
- Warranty
- Inquiry



Function Name	Description	Display
Option fault	Appears if a contact fault or the like of the connector between the inverter and communication option occurs or if a communication option is fitted to the connector 1 or 2. (1 to 3 indicate connector numbers for connection of the plug-in option.)	E. 1 to E. 3
Parameter storage device fault	Appears when operation of the element where parameters stored became abnormal. (control circuit board)	E. PE
PU disconnection *8	Appears when a communication error between the PU and inverter occurred, the communication interval exceeded the permissible time during the RS-485 communication with the PU connector, or communication errors exceeded the number of retries during the RS-485 communication.	EPUE
Retry count excess *8	Appears when the operation was not restarted within the set number of retries.	ErEr
Parameter storage device fault	Appears when operation of the element where parameters stored became abnormal. (main circuit board)	EPe2
CPU fault	Appears during the CPU and peripheral circuit errors occurred.	E. 5 to E. 7 E.CPU
Operation panel power supply short circuit, RS-485 terminal power supply short circuit	Appears when the RS-485 terminal power supply or operation panel power supply was shorted.	EECE
24VDC power output short circuit	Appears when terminals PC-SD were shorted.	EP24
Output current detection value exceeded *8	Appears when output current exceeded the output current detection level set by the parameter.	EEJO
Inrush resistor overheat	Appears when the resistor of the inrush current limit circuit overheated.	EIOH
Communication error (inverter)	Appears when a communication error occurred during the RS-485 communication with the RS-485 terminals.	ESEr
Analog input fault	Stops the inverter output when a 30mA or higher current or a 7.5V or higher voltage is input to terminal 2 while the current input is selected by Pr.73 Analog input selection, or to terminal 4 while the current input is selected by Pr.267 Terminal 4 input selection.	EAI E
Overspeed occurrence *7 *8	Indicates that the motor speed has exceeded the overspeed setting level (Pr.374).	E. 05
Speed deviation excess detection *7 *8	Stops the inverter output if the motor speed is increased or decreased under the influence of the load etc. during vector control and cannot be controlled in accordance with the speed command value.	E05d
Signal loss detection *7 *8	Stops the inverter output if the encoder signal is shut off.	EEEr
Position error large *7 *8	Indicates that the difference between the position command and position feedback exceeded the reference.	E. 0d
Brake sequence error *8	The inverter output is stopped when a sequence error occurs during use of the brake sequence function (Pr.278 to Pr.285).	ENb 1 to ENb7
Encoder phase error *7 *8	When the rotation command of the inverter differs from the actual motor rotation direction detected from the encoder, the inverter output is stopped. (detected only during tuning is performed in the "rotation mode" of offline auto tuning)	EEP
Converter overcurrent	Appears when an overcurrent occurred in the converter side circuit.	E. 4
Power supply fault	Appears when power supply frequency fault is detected, input voltage phase is not detected, etc.	E. 8
Converter transistor protection thermal operation (electronic thermal)	Appears when the electronic thermal relay for converter output element protection was activated.	E. 10
Opposite rotation deceleration alarm	The speed may not decelerate during low speed operation if the rotation direction of the speed command and the estimated speed differ when the rotation is changing from forward to reverse or from reverse to forward under real sensorless vector control. At this time, the inverter output is stopped if the rotation direction will not change, causing overload.	E. 11
Internal circuit fault	Appears when an internal circuit error occurred.	E. 13
USB error	Appears when USB communication error occurred.	EUSB
Converter circuit fault	Appears when a fault is detected in the converter side circuit.	E. 15

\*1. Resetting the inverter initializes the internal cumulative heat value data of the electronic thermal relay function.  
 \*2. The error message shows an operational error. The inverter output does not trip.  
 \*3. Warnings are messages given before fault occur. The inverter output does not trip.  
 \*4. Alarm warns the operator of failures with output signals. The inverter output does not trip.  
 \*5. When a fault occurs, the inverter trips and a fault signal is output.  
 \*6. The external thermal operates only when the OH signal is set in Pr.178 to Pr.189 (input terminal function selection).  
 \*7. Appears when the FR-A7AP/FR-A7AL (option) is fitted.  
 \*8. This protective function is not available in the initial status.

# Option and Peripheral Devices

## Option List

By attaching the following options to the inverter, the inverter is provided with more functions. Three plug-in options can be attached at a time. (Two of the same options cannot be used. Only one communication option can be used.)

Name		Model	Applications, Specifications, etc.	Applicable Inverter	
Plug-in Type	Vector control	FR-A7AP	Vector control with encoder can be performed.	All models (While FR-A7AL is mounted, only one other option can be used at the same time.)	
	Orientation/encoder feedback		The main spindle can be stopped at a fixed position (orientation) in combination with a pulse encoder. The motor speed is sent back and the speed is maintained constant.		
	Position control	FR-A7AL	Position control can be performed with pulse train inputs from an external device. This option can be connected to a programmable controller (positioning module).		
	Encoder pulse dividing output		This option divides the pulse train outputs received from an encoder and outputs the divided data.		
	16-bit digital input	FR-A7AX	<ul style="list-style-type: none"> <li>This input interface sets the high frequency accuracy of the inverter using an external BCD or binary digital signal.</li> <li>BCD code 3 digits</li> <li>BCD code 4 digits</li> <li>Binary 12 bits</li> <li>Binary 16 bits</li> </ul>	All models	
	Digital output Extension analog output	FR-A7AY	<ul style="list-style-type: none"> <li>Output signals provided with the inverter as standard are selected to output from the open collector.</li> <li>This option adds two different signals that can be monitored at the terminals AM0 and AM1, such as the output frequency, output voltage and output current.</li> <li>20mADC or 10VDC meter can be connected.</li> </ul>		
	Relay output		FR-A7AR		Output any three output signals available with the inverter as standard from the relay contact terminals.
	Extension outputs Extension inputs Thermistor interface	FR-A7AZ	<ul style="list-style-type: none"> <li>This option extends monitors such as motor torque, torque command, etc. to output <math>\pm 10V</math>.</li> <li>High precision operation can be performed by using high resolution analog input (16 bit).</li> <li>The fluctuation of torque generated can be reduced by detecting the motor temperature using the motor with thermistor.</li> </ul>		
	Communication		CC-Link communication		FR-A7NC
		LONWORKS communication	FR-A7NL		
DeviceNet communication		FR-A7ND			
PROFIBUS-DP communication		FR-A7NP			
SSCNET III communication		FR-A7NS			
Stand-alone Shared	Parameter unit (8 languages)	FR-PU07 FR-PU04	Interactive parameter unit with LCD display	All models	
	Parameter unit with battery pack	FR-PU07BB	This parameter unit enables parameter setting without connecting the inverter to power supply.	All models	
	Parameter unit connection cable	FR-CB20□	Cable for connection of operation panel or parameter unit □ indicates a cable length. (1m, 3m, 5m)	All models	
	Operation panel connection connector	FR-ADP	Connector to connect the operation panel (FR-DU07) and connection cable		
	Cable for encoder Mitsubishi vector control dedicated motor (SF-V5RU)	FR-V7CBL□□	Connection cable for the inverter and encoder for Mitsubishi vector control dedicated motor (SF-V5RU). □ indicates a cable length. (5m, 15m, 30m)		
	Radio noise filter	FR-BIF(H)	For radio noise reduction (connect to the input side)		
	Line noise filter	FR- BLF	For line noise reduction		
	EMC Directive compliant EMC filter	SF□□	EMC Directive (EN61800-5-1) compliant noise filter. (EU Directive compliant)	400V: Depends on capacity	
	Surge voltage suppression filter	FR-ASF	Filter for suppressing surge voltage on motor	400V: Depends on capacity	
		FR-BMF		400V: For the 5.5K to 37K	

Features

Standard Specifications

Outline Dimension Drawings

Terminal Connection Diagram Terminal Specification Explanation

Parameter List

Protective Functions

Options

Instructions

Warranty

Inquiry

	Name	Model	Applications, Specifications, etc.	Applicable Inverter
FR Series Manual Controller/Speed Controller	Manual controller	FR-AX	For independent operation. With frequency meter, frequency potentiometer and start switch.	Shared among all models
	DC tach. follower	FR-AL	For synchronous operation (1VA) by external signal (0 to 5V, 0 to 10V DC) *	
	Three speed selector	FR-AT	For three speed switching, among high, middle and low speed operation (1.5VA) *	
	Motorized speed setter	FR-FK	For remote operation. Allows operation to be controlled from several places (5VA) *	
	Ratio setter	FR-FH	For ratio operation. Allows ratios to be set to five inverters. (3VA)*	
	Speed detector	FR-FP	For tracking operation by a pilot generator (PG) signal (3VA) *	
	Master controller	FR-FG	Master controller (5VA) for parallel operation of multiple (maximum 35) inverters. *	
	Soft starter	FR-FC	For soft start and stop. Enables acceleration/deceleration in parallel operation (3VA) *	
	Deviation detector	FR-FD	For continuous speed control operation. Used in combination with a deviation sensor or synchro (5VA) *	
	Preamplifier	FR-FA	Used as an A/V converter or arithmetic amplifier (3VA) *	
Others	Pilot generator	QVAH-10	For tracking operation. 70V/35VAC 500Hz (at 2500r/min)	
	Deviation sensor	YVGC-500W-NS	For continuous speed control operation (mechanical deviation detection) Output 90VAC/90°	
	Frequency setting potentiometer	WA2W 1kΩ	For frequency setting. Wire-wound 2W 1kΩ type B characteristic	
	Analog frequency meter (64mm × 60mm)	YM206NRI 1mA	Dedicated frequency meter (graduated to 120Hz). Moving-coil type DC ammeter	
	Calibration resistor	RV24YN 10kΩ	For frequency meter calibration. Carbon film type B characteristic	
	Inverter setup software (FR Configurator)	FR-SW3-SETUP-WE	Supports an inverter startup to maintenance.	

\* Rated power consumption. The power supply specifications of the FR series manual controllers and speed controllers are 200VAC 50Hz, 220V/220VAC 60Hz, and 115VAC 60Hz.

## Stand-alone Option

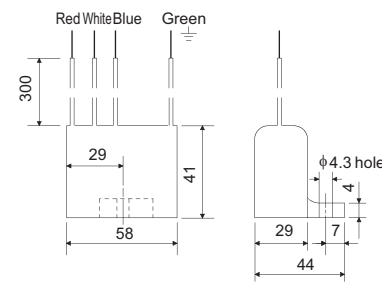
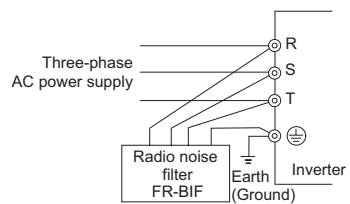
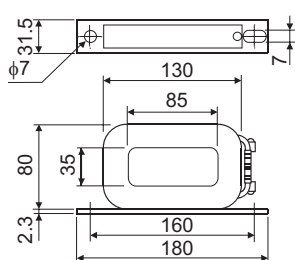
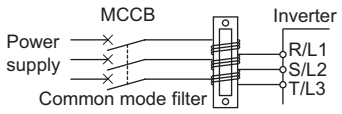
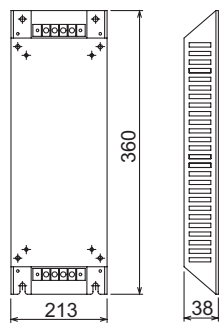
Name (model)	Specifications, Structure, etc.																																																														
Radio noise filter FR-BIF	<ul style="list-style-type: none"> <li>● Outline dimension FR-BIF</li> </ul>  <p>(Unit: mm)</p>	<ul style="list-style-type: none"> <li>● Connection diagram</li> </ul>  <p>(Note) 1. Connect to the inverter input side. Connect the filter directly to the inverter input terminal. 2. Since long connection wire reduces effect, the wire length should be minimized. Make sure to perform earthing with resistance of 100Ω or less.</p>																																																													
Line noise filter FR-BLF	<ul style="list-style-type: none"> <li>● Outline dimension FR-BLF</li> </ul>  <p>(Unit: mm)</p>	 <p>(Note) 1. Each phase should be wound at least 3 times (4T, 4 turns) in the same direction. (The greater the number of turns, the more effective result is obtained.) When using several line noise filters to make 4T or more, wind the phases (cables) together. Do not use different line noise filters for different phases. 2. When the thickness of the wire prevents winding, use at least 4 in series and ensure that the current passes through each phase in the same direction. 3. Can be used on the output side in the same way as the input side. When using a line noise filter at the output side, the filter body may heat up. Do not wind the cable more than 3 times (4T) for each line noise filter installed at the output side. 4. Do not wind an earthing cable.</p>																																																													
EMC Directive compliant EMC filter SF□□ (EU Directive compliant)	<ul style="list-style-type: none"> <li>● This noise filter complies with the European EMC Directive. (400V class)</li> <li>● Outline dimension</li> </ul> <table border="1" data-bbox="367 1164 1053 1288"> <thead> <tr> <th>Noise filter model</th> <th>Applicable inverter model</th> <th>Approx. Mass (kg)</th> <th>Leakage current reference value (mA)</th> </tr> </thead> <tbody> <tr> <td>400V SF1174B</td> <td>FR-A741-5.5K, 7.5K</td> <td>1.8</td> <td>51</td> </tr> </tbody> </table>  <p>(Unit: mm)</p> <table border="1" data-bbox="367 1534 1141 1736"> <thead> <tr> <th rowspan="2">Noise filter model</th> <th rowspan="2">Applicable inverter model</th> <th colspan="4">Outline Dimension</th> <th rowspan="2">Approx. Mass (kg)</th> <th rowspan="2">Leakage current reference value (mA)</th> </tr> <tr> <th>W</th> <th>H</th> <th>D</th> <th>D1</th> </tr> </thead> <tbody> <tr> <td rowspan="5">400V</td> <td>SF1175</td> <td>FR-A741-11K, 15K</td> <td>253</td> <td>530</td> <td>60</td> <td>25</td> <td>4.7</td> <td>76</td> </tr> <tr> <td>SF1176</td> <td>FR-A741-18.5K, 22K</td> <td>303</td> <td>600</td> <td>60</td> <td>29</td> <td>5.9</td> <td>108</td> </tr> <tr> <td>SF1177</td> <td>FR-A741-30K</td> <td>327</td> <td>700</td> <td>80</td> <td>29</td> <td>9.4</td> <td>156</td> </tr> <tr> <td>SF1178</td> <td>FR-A741-37K, 45K</td> <td>450</td> <td>770</td> <td>80</td> <td>36</td> <td>16</td> <td>156</td> </tr> <tr> <td>SF1179</td> <td>FR-A741-55K</td> <td>467</td> <td>920</td> <td>80</td> <td>36</td> <td>19</td> <td>156</td> </tr> </tbody> </table> <ul style="list-style-type: none"> <li>● Measures against leakage currents</li> </ul> <p>Take the following measures to prevent a peripheral device malfunction or electric shock accident from occurring due to a leakage current.</p> <ol style="list-style-type: none"> <li>Ground (earth) the EMC filter before connecting the power supply. In that case, make certain that grounding (earthing) is securely performed via the grounding (earthing) part of the enclosure.</li> <li>Select the earth leakage circuit breaker or earth leakage relay in consideration of the EMC filter's leakage current *. When the leakage current of the EMC filter is too large to use the earth leakage circuit breaker or earth leakage relay, securely perform grounding (earthing) as described in 1.</li> </ol> <p>* The leakage current indicated is equivalent to one-phase of three-phase three wire <math>\Delta</math> connection power supply. For a three-phase, three-wire, delta-connection power supply, the value is about three times greater than the indicated. Some noise filters available on the market have small leakage current, although they are not European Directive compliant.</p>		Noise filter model	Applicable inverter model	Approx. Mass (kg)	Leakage current reference value (mA)	400V SF1174B	FR-A741-5.5K, 7.5K	1.8	51	Noise filter model	Applicable inverter model	Outline Dimension				Approx. Mass (kg)	Leakage current reference value (mA)	W	H	D	D1	400V	SF1175	FR-A741-11K, 15K	253	530	60	25	4.7	76	SF1176	FR-A741-18.5K, 22K	303	600	60	29	5.9	108	SF1177	FR-A741-30K	327	700	80	29	9.4	156	SF1178	FR-A741-37K, 45K	450	770	80	36	16	156	SF1179	FR-A741-55K	467	920	80	36	19	156
Noise filter model	Applicable inverter model	Approx. Mass (kg)	Leakage current reference value (mA)																																																												
400V SF1174B	FR-A741-5.5K, 7.5K	1.8	51																																																												
Noise filter model	Applicable inverter model	Outline Dimension				Approx. Mass (kg)	Leakage current reference value (mA)																																																								
		W	H	D	D1																																																										
400V	SF1175	FR-A741-11K, 15K	253	530	60	25	4.7	76																																																							
	SF1176	FR-A741-18.5K, 22K	303	600	60	29	5.9	108																																																							
	SF1177	FR-A741-30K	327	700	80	29	9.4	156																																																							
	SF1178	FR-A741-37K, 45K	450	770	80	36	16	156																																																							
	SF1179	FR-A741-55K	467	920	80	36	19	156																																																							

Features
Standard Specifications
Outline Dimension Drawings
Terminal Connection Diagram Terminal Specification Explanation
Parameter List
Protective Functions
Options
Instructions
Warranty
Inquiry

Name (model)

Specifications, Structure, etc.

- When driving the 400V class motor by the inverter, this filter suppresses the surge voltage generated at the motor terminal.
- This can be applied to FR-A741-5.5K to 37K.
- This can be applied to the non insulation-enhanced motor.
- Specifications

Model FR-BMF-H□K	7.5	15	22	37				
Applicable inverter capacity *1	5.5	7.5	11	15	18.5	22	30	37
Rated current (A)	17		31		43		71	
Overload current rating *2	150% 60s, 200% 0.5s (inverse-time characteristics)							
Rated input AC voltage *2	Three phase 380 to 480V							
Permissible AC voltage fluctuation *2	323 to 528V							
Maximum frequency *2	120Hz							
PWM carrier frequency	2kHz or less *3							
Protective structure (JEM 1030)	Open type (IP00)							
Cooling system	Self-cooling							
Maximum wiring length	100m or less							
Approximate mass (kg)	5.5	9.5	11.5	19				
Environment	Ambient temperature	-10°C to +50°C (non-freezing)						
	Ambient humidity	90%RH maximum (non-condensing)						
	Atmosphere	Indoors (free from corrosive gas, flammable gas, oil mist, dust and dirt)						
	Altitude/vibration	Maximum 1,000m above sea level, 5.9m/s <sup>2</sup> or less *4 at 10 to 55Hz (direction of X, Y, Z axes)						

• Connection diagram

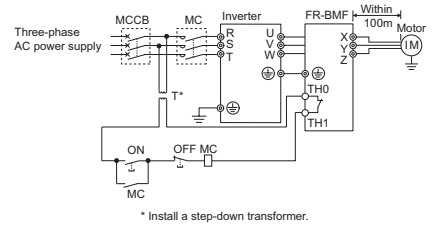

\*1 The applied motor capacity indicated is the maximum capacity applicable for use of the Mitsubishi 4-pole standard motor.  
 \*2 The capacity depends on the specifications of the inverter (400V class) connected.  
 \*3 The setting of Pr. 72 PWM frequency selection should be 2kHz or less.  
 \*4 When using with the filter installed on the rear panel, do not install this combination on moving objects or places that have vibrations (exceeding 1.96m/s<sup>2</sup>).

• Outline dimension  
 • FR-BMF-H7.5K

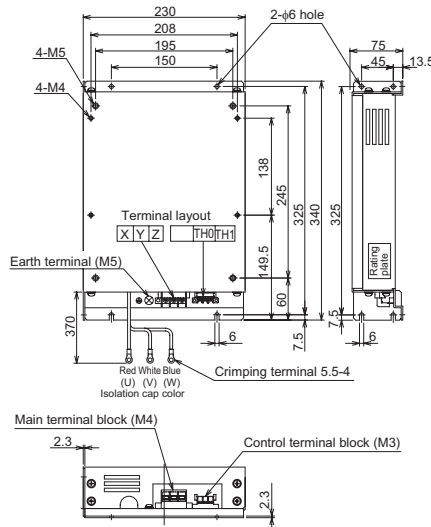

• FR-BMF-H15K, H22K

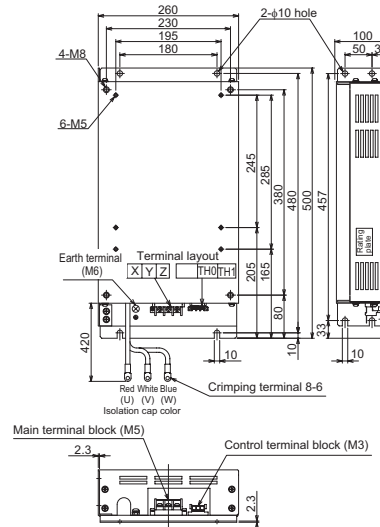

• FR-BMF-H37K

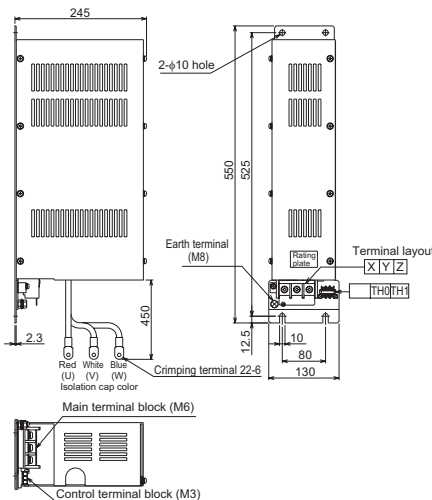

Surge voltage suppression filter  
FR-BMF-H□□K

(Unit: mm)

## Dedicated cable option

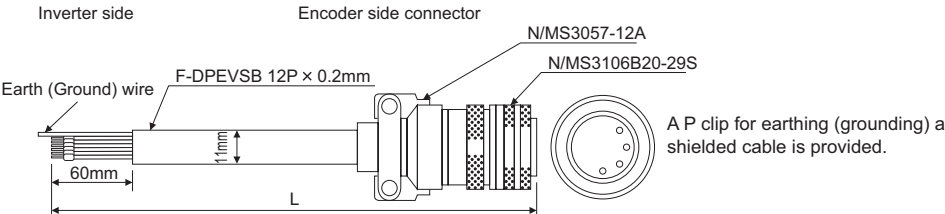
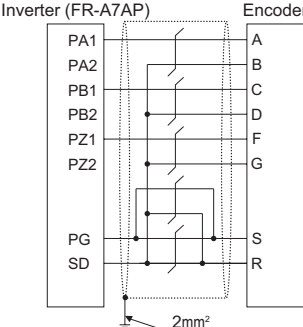
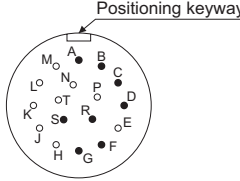
Name (model)	Specifications, Structure, etc.																																				
Cable for encoder FR-V7CBL□□	<p>● For dedicated motor</p>  <p>Inverter side Encoder side connector</p> <p>Earth (Ground) wire F-DPEVSB 12P × 0.2mm N/MS3057-12A N/MS3106B20-29S</p> <p>60mm 1mm L</p> <p>A P clip for earthing (grounding) a shielded cable is provided.</p>  <p>Inverter (FR-A7AP) Encoder</p> <p>PA1 PA2 PB1 PB2 PZ1 PZ2 PG SD A B C D F G S R</p> <p>2mm<sup>2</sup></p>  <p>Positioning keyway</p> <p>N/MS3106B20-29S (As viewed from wiring side)</p> <table border="1" data-bbox="981 828 1236 929"> <thead> <tr> <th>Model</th> <th>Length L (m)</th> </tr> </thead> <tbody> <tr> <td>FR-V7CBL5</td> <td>5</td> </tr> <tr> <td>FR-V7CBL15</td> <td>15</td> </tr> <tr> <td>FR-V7CBL30</td> <td>30</td> </tr> </tbody> </table> <p>(Note) When a cable of 30m length or more is required, consult our sales office.</p> <p>● Cable selection specifications</p> <p>If connection cables are not available, make cables according to the following table. When connecting terminals PG and SD to encoder on motor, make parallel connection or use larger gauge cables. (Use cables of 0.2mm<sup>2</sup> to wire other terminals.)</p> <table border="1" data-bbox="383 1086 1141 1288"> <thead> <tr> <th rowspan="2">Wiring Distance</th> <th rowspan="2">Optional Encoder Dedicated Cable</th> <th colspan="2">Cable specifications for terminals PG and SD</th> </tr> <tr> <th>Wiring 0.2mm<sup>2</sup> cables</th> <th>Using larger gauge cable</th> </tr> </thead> <tbody> <tr> <td>5m or less</td> <td>FR-V7CBL5</td> <td>2 parallels or more</td> <td rowspan="2">0.4mm<sup>2</sup> or more</td> </tr> <tr> <td>10m or less</td> <td rowspan="3">FR-V7CBL15</td> <td>2 parallels or more</td> </tr> <tr> <td>15m or less</td> <td>4 parallels or more</td> <td rowspan="2">0.75mm<sup>2</sup> or more</td> </tr> <tr> <td>20m or less</td> <td>4 parallels or more</td> </tr> <tr> <td>30m or less</td> <td rowspan="2">FR-V7CBL30</td> <td>6 parallels or more</td> <td rowspan="2">1.25mm<sup>2</sup> or more</td> </tr> <tr> <td>50m or less</td> <td>6 parallels or more</td> </tr> <tr> <td>100m or less</td> <td>*Available on request, please consult us.</td> <td>6 parallels or more</td> <td></td> </tr> </tbody> </table>	Model	Length L (m)	FR-V7CBL5	5	FR-V7CBL15	15	FR-V7CBL30	30	Wiring Distance	Optional Encoder Dedicated Cable	Cable specifications for terminals PG and SD		Wiring 0.2mm <sup>2</sup> cables	Using larger gauge cable	5m or less	FR-V7CBL5	2 parallels or more	0.4mm <sup>2</sup> or more	10m or less	FR-V7CBL15	2 parallels or more	15m or less	4 parallels or more	0.75mm <sup>2</sup> or more	20m or less	4 parallels or more	30m or less	FR-V7CBL30	6 parallels or more	1.25mm <sup>2</sup> or more	50m or less	6 parallels or more	100m or less	*Available on request, please consult us.	6 parallels or more	
	Model	Length L (m)																																			
FR-V7CBL5	5																																				
FR-V7CBL15	15																																				
FR-V7CBL30	30																																				
Wiring Distance	Optional Encoder Dedicated Cable	Cable specifications for terminals PG and SD																																			
		Wiring 0.2mm <sup>2</sup> cables	Using larger gauge cable																																		
5m or less	FR-V7CBL5	2 parallels or more	0.4mm <sup>2</sup> or more																																		
10m or less	FR-V7CBL15	2 parallels or more																																			
15m or less		4 parallels or more	0.75mm <sup>2</sup> or more																																		
20m or less		4 parallels or more																																			
30m or less	FR-V7CBL30	6 parallels or more	1.25mm <sup>2</sup> or more																																		
50m or less		6 parallels or more																																			
100m or less	*Available on request, please consult us.	6 parallels or more																																			

## Encoder connector (Manufactured by Japan Aviation Electronics Industry, Limited) for reference

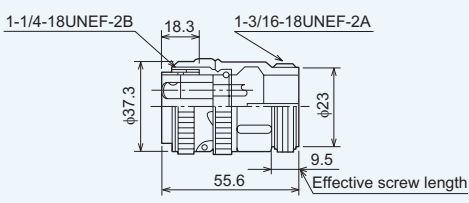
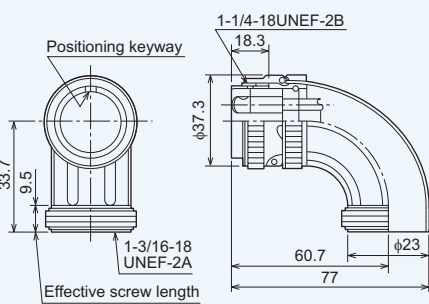
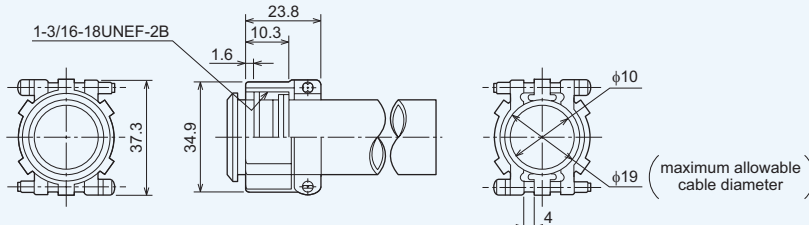
Straight Plug N/MS3106B20-29S	Angle Plug N/MS3108B20-29S
 <p>1-1/4-18UNEF-2B 18.3 1-3/16-18UNEF-2A 37.3 23 55.6 9.5 Effective screw length</p>	 <p>1-1/4-18UNEF-2B 18.3 33.7 9.5 1-3/16-18 UNEF-2A 60.7 77 23 Effective screw length</p> <p>(Note) This angle type connector is not optional. Please obtain it separately.</p>
Cable Clamp N/MS3057-12A	
 <p>1-3/16-18UNEF-2B 23.8 10.3 1.6 37.3 34.9 10 19 (maximum allowable cable diameter) 4</p>	

(Unit: mm)

- Features
- Standard Specifications
- Outline Dimension Drawings
- Terminal Connection Diagram Terminal Specification Explanation
- Parameter List
- Protective Functions
- Options
- Instructions
- Warranty
- Inquiry

## Peripheral devices/cable size list

Voltage	Motor Output (kW) *1	Applicable Inverter Model	Breaker Selection *2	Input Side Magnetic Contactor *3	Recommended Cable Size (mm <sup>2</sup> ) *4	
					R, S, T	U, V, W
200V class	5.5	FR-A721-5.5K	40A	S-N20, N21	5.5	5.5
	7.5	FR-A721-7.5K	50A	S-N25	14	8
	11	FR-A721-11K	75A	S-N35	14	14
	15	FR-A721-15K	100A	S-N50	22	22
	18.5	FR-A721-18.5K	125A	S-N50	38	38
	22	FR-A721-22K	150A	S-N65	38	38
	30	FR-A721-30K	175A	S-N80	60	60
	37	FR-A721-37K	225A	S-N125	80	80
	45	FR-A721-45K	300A	S-N150	100	100
400V class	5.5	FR-A741-5.5K	20A	S-N11, N12	2	2
	7.5	FR-A741-7.5K	30A	S-N20, N21	3.5	3.5
	11	FR-A741-11K	40A	S-N20, N21	5.5	5.5
	15	FR-A741-15K	50A	S-N20, N21	8	8
	18.5	FR-A741-18.5K	60A	S-N25	14	8
	22	FR-A741-22K	75A	S-N25	14	14
	30	FR-A741-30K	100A	S-N50	22	22
	37	FR-A741-37K	125A	S-N50	22	22
	45	FR-A741-45K	150A	S-N65	38	38
55	FR-A741-55K	175A	S-N80	60	60	

\*1 Selections for use of the Mitsubishi 4-pole standard motor with power supply voltage of 200VAC(200V class)/400VAC(400V class) 50Hz.

\*2 Select the MCCB according to the power supply capacity.  
 Install one MCCB per inverter.  
 For the use in the United States or Canada, provide the appropriate UL and cUL listed Class RK5 or Class T type fuse or UL 489 molded case circuit breaker (MCCB) that is suitable for branch circuit protection.  
 For details, refer to the Instruction Manual.

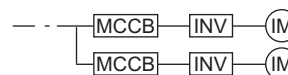

\*3 Magnetic contactor is selected based on the AC-1 class. The electrical durability of magnetic contactor is 500,000 times. When the magnetic contactor is used for emergency stop during motor driving, the electrical durability is 25 times.  
 When using the MC for emergency stop during motor driving or using on the motor side during commercial-power supply operation, select the MC with class AC-3 rated current for the motor rated current.

\*4 Cable  
 The cable size is that of the cable (HIV cable (600V class 2 vinyl-insulated cable) etc.) with continuous maximum permissible temperature of 75°C. Assumes that the surrounding air temperature is 50°C or less and the wiring distance is 20m or less.

### CAUTION

When the breaker on the inverter primary side trips, check for the wiring fault (short circuit), damage to internal parts of the inverter, etc. Identify the cause of the trip, then remove the cause and power on the breaker.

## Selection of rated sensitivity current of earth (ground) leakage current breaker

When using the earth leakage current breaker with the inverter circuit, select its rated sensitivity current as follows, independently of the PWM carrier frequency.

- Breaker designed for harmonic and surge suppression  
Rated sensitivity current:  $I_{\Delta n} \geq 10 \times (I_{g1} + I_{gn} + I_{gi} + 3 \times I_{g2} + I_{gm})$
  - Standard breaker  
Rated sensitivity current:  $I_{\Delta n} \geq 10 \times \{(I_{g1} + I_{gn} + I_{gi} + 3 \times (I_{g2} + I_{gm}))\}$
- $I_{g1}, I_{g2}$  : Leakage currents in wire path during commercial power supply operation  
 $I_{gn}$  : Leakage current of inverter input side noise filter  
 $I_{gm}$  : Leakage current of motor during commercial power supply operation  
 $I_{gi}$  : Inverter unit leakage current

Example of leakage current of cable path per 1km during the commercial power supply operation when the CV cable is routed in metal conduit (200V 60Hz)

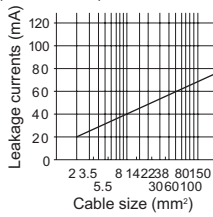

Leakage current example of three-phase induction motor during the commercial power supply operation (200V 60Hz)

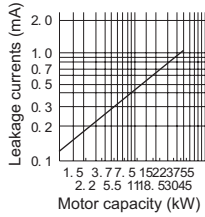

Example of leakage current per 1km during the commercial power supply operation when the CV cable is routed in metal conduit (Three-phase three-wire delta connection 400V60Hz)

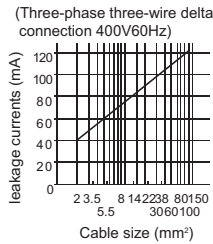

Leakage current example of three-phase induction motor during the commercial power supply operation (Totally-enclosed fan-cooled type motor 400V60Hz)

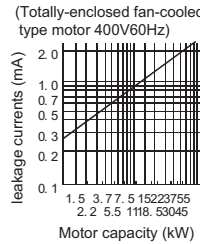

For "Δ" connection, the amount of leakage current is approx. 1/3 of the above value.

### Example

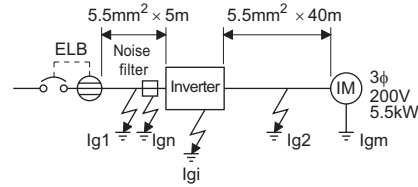

- Note: 1. Install the earth leakage current breaker (ELB) on the input side of the inverter.  
 2. In the Δ connection earthed-neutral system, the sensitivity current is purified against an earth (ground) fault in the inverter output side. Earthing (Grounding) must conform to the requirements of national and local safety regulations and electrical codes. (NEC section 250, IEC 536 class 1 and other applicable standards)

### ● Selection example (in the case of the above figure)

	Breaker Designed For Harmonic and Surge Suppression	Standard Breaker
Leakage current $I_{g1}$ (mA)	$33 \times \frac{5m}{1,000m} = 0.17$	
Leakage current $I_{gn}$ (mA)	0 (without noise filter)	
Leakage current $I_{gi}$ (mA)	1	
Leakage current $I_{g2}$ (mA)	$33 \times \frac{40m}{1,000m} = 1.32$	
Motor leakage current $I_{gm}$ (mA)	0.29	
Total leakage current (mA)	2.78	6.00
Rated sensitivity current (mA) ( $\geq I_g \times 10$ )	30	100

Features

Standard Specifications

Outline Dimension Drawings

Terminal Connection Diagram Terminal Specification Explanation

Parameter List

Protective Functions

Options

Instructions

Warranty

Inquiry



# Precautions for Operation/Selection

## Precautions for use of the inverter

### ⚠ Safety Precautions

- To operate the inverter correctly and safely, be sure to read the "instruction manual" before starting operation.
- This product has not been designed or manufactured for use with any equipment or system operated under life-threatening conditions.
- Please contact our sales office when you are considering using this product in special applications such as passenger mobile, medical, aerospace, nuclear, power or undersea relay equipment or system.
- Although this product is manufactured under strict quality control, safety devices should be installed when a serious accident or loss is expected by a failure of this product.
- The load used should be a three-phase induction motor only.

## Operation

- A magnetic contactor (MC) provided on the input side should not be used to make frequent starts and stops. It could cause the inverter to fail.
- At the inverter alarm occurrence, the protective function activates to stop output. However, at this time, the motor cannot be brought to a sudden stop. Hence, provide a mechanical stopping/holding mechanism for the machine/equipment which requires an emergency stop.
- It will take time for the capacitor to discharge after shutoff of the inverter power supply. When accessing the inverter for inspection, wait for at least 10 minutes after the power supply has been switched off, and check to make sure that there are no residual voltage using a tester or the like.

## Wiring

- Application of power to the output terminals (U, V, W) of the inverter will damage the inverter. Therefore, fully check the wiring and sequence to ensure that wiring is correct, etc. before powering on.
- Do not use P/+ and N/-. Do not short the frequency setting power supply terminal 10 and common terminal 5 or the terminal PC and terminal SD.

## Power supply

- This inverter has a built-in AC reactor (FR-HAL) and a circuit type specified in Harmonic suppression guideline in Japan is three-phase bridge (capacitor smoothed) and with reactor (AC side). (Refer to page 36)  
A DC reactor (FR-HEL) can not be connected to the inverter.

## Installation

- Avoid hostile environment where oil mist, fluff, dust particles, etc. are suspended in the air, and install the inverter in a clean place or put it in an ingress-protected "enclosed" enclosure. When placing the inverter in an enclosure, determine the cooling system and enclosure dimensions so that the ambient temperature of the inverter is within the permissible value. (refer to page 4 for the specified value)
- Do not install the inverter on wood or other combustible material as it will be hot locally.
- Install the inverter in the vertical orientation.

## Setting

- The inverter can be operated as fast as a maximum of 400Hz by parameter setting. Therefore, incorrect setting can cause a danger. Set the upper limit using the maximum frequency limit setting function.
- A setting higher than the initial value of DC injection brake operation voltage or operation time can cause motor overheat (electronic thermal relay trip).

## Real sensorless vector control

- Make sure to perform offline auto tuning before performing real sensorless vector control.
- The carrier frequencies are selectable from among 2k, 6k, 10k, 14kHz for real sensorless vector control.
- Torque control can not be performed in the low speed (approx. 10Hz or less) regeneration range and with light load at low speed (approx. 20% or less of rated torque at approx. 5Hz or less). Choose vector control.
- Performing pre-excitation (LX signal and X13 signal) under torque control may start the motor running at a low speed even when the start command (STF or STR) is not input. The motor may run also at a low speed when the speed limit value=0 with a start command input. Perform pre-excitation after making sure that there will be no problem in safety if the motor runs.
- Do not switch between the STF (forward rotation command) and STR (reverse rotation command) during operation under torque control. Overcurrent shut-off error (E.OC□) or opposite rotation deceleration error (E.11) occurs.
- When the inverter is likely to start during motor coasting under real sensorless vector control, set to make frequency search of automatic restart after instantaneous power failure valid (Pr: 57 ≠ "9999", Pr: 162 = "10").
- Enough torque may not be generated in the ultra-low speed range less than approx. 2Hz when performing real sensorless vector control.

The guideline of speed control range is as shown below.

Driving:	1:200 (2, 4, 6 poles)
	Can be used at 0.3Hz or more at rated 60Hz
	1:30 (8, 10 poles)
	Can be used at 2Hz or more at rated 60Hz
Regeneration:	1:12 (2 to 10 poles)
	Can be used at 5Hz or more at rated 60Hz

## Precautions for selection

### Inverter capacity selection

- When operating a special motor or more than one motor in parallel with a single inverter, select the inverter capacity so that 1.1 times the total rated motor current is less than the rated output current of the inverter.
- For the vector control dedicated motor (SF-V5RU(H)), the inverter one or two ranks higher than the motor in capacity needs to be selected depending on the motor capacity.  
Refer to the FR-A700 series catalog in which the motor specifications and outline dimension drawings.

### Starting torque of the motor

- The start and acceleration characteristics of the motor driven by the inverter are restricted by the overload current rating of that inverter. Generally the torque characteristic is less than when the motor is started by a commercial power supply. When torque boost adjustment, advanced magnetic flux vector, real sensorless vector or vector control cannot provide enough starting torque, select the inverter of one rank higher capacity or increase the capacities of both the motor and inverter.

### Acceleration/deceleration times

- The acceleration/deceleration time of the motor depends on the motor-generated torque, load torque and load inertia moment ( $GD^2$ ).
- When the torque limit function or stall prevention function is activated during acceleration/deceleration, increase the acceleration/deceleration time as the actual time may become longer.
- To decrease the acceleration/deceleration time, increase the torque boost value (setting of a too large value may activate the stall prevention function at a start, resulting in longer acceleration time), use the advanced magnetic flux vector control, real sensorless vector control or vector control, or increase the inverter and motor capacities.

### Power transfer mechanism (reduction gear, belt, chain, etc.)

- When an oil-lubricated gear box, speed change/reduction gear or similar device is used in the power transfer system, note that continuous operation at low speed only may deteriorate oil lubrication, causing seizure. When performing fast operation at higher than 60Hz, fully note that such operation will cause strength shortage due to the noise, life or centrifugal force of the power transfer mechanism.

### Instructions for overload operation

- When performing operation of frequent start/stop of the inverter, rise/fall in the temperature of the transistor element of the inverter will repeat due to a repeated flow of large current, shortening the life from thermal fatigue. Since thermal fatigue is related to the amount of current, the life can be increased by reducing current at locked condition, starting current, etc. Decreasing current may increase the life. However, decreasing current will result in insufficient torque and the inverter may not start. Therefore, choose the inverter which has enough allowance for current.

# Precautions for Peripheral Device Selection

## Installation and selection of moulded case circuit breaker

Install a moulded case circuit breaker (MCCB) on the power receiving side to protect the wiring of the inverter input side. For MCCB selection, refer to page 31 since it depends on the inverter power supply side power factor (which changes depending on the power supply voltage, output frequency and load). Especially for a completely electromagnetic MCCB, one of a slightly large capacity must be selected since its operation characteristic varies with harmonic currents. (Check it in the data of the corresponding breaker.) As an earth leakage current breaker, use the Mitsubishi earth leakage current breaker designed for harmonics and surge suppression. (Refer to page 32.)

When installing a moulded case circuit breaker on the output side of the inverter, contact each manufacturer for selection of the moulded case circuit breaker.

## Handling of primary side magnetic contactor

For operation via external terminal (terminal STF or STR used), provide an input side MC to prevent an accident caused by a natural restart at power recovery after a power failure, such as an instantaneous power failure, and to ensure safety for maintenance work. Do not use this magnetic contactor to make frequent starts and stops. (The switching life of the inverter input circuit is about 1,000,000 times.) For parameter unit operation, an automatic restart after power failure is not made and the MC cannot be used to make a start. Note that the primary side MC may be used to make a stop but the regenerative brake specific to the inverter does not operate and the motor is coasted to a stop.

## Handling of the secondary side magnetic contactor

Switch the magnetic contactor between the inverter and motor only when both the inverter and motor are at a stop. When the magnetic contactor is turned on while the inverter is operating, overcurrent protection of the inverter and such will activate. When an MC is provided to switch to a commercial power supply, for example, it is recommended to use bypass operation Pr.135 to Pr.139.

## Thermal relay installation

The inverter has an electronic thermal relay function to protect the motor from overheating. However, when running multiple motors with one inverter or operating a multi-pole motor, provide a thermal relay (OCR) between the inverter and motor. In this case, set the electronic thermal relay function of the inverter to 0A. And for the setting of the thermal relay, add the line-to-line leakage current (refer to page 36) to the current value on the motor rating plate. For low-speed operation where the cooling capability of the motor reduces, it is recommended to use a thermal protector or thermistor-incorporated motor.

## Measuring instrument on the output side

When the inverter-to-motor wiring length is large, especially in the 400V class, small-capacity models, the meters and CTs may generate heat due to line-to-line leakage current. Therefore, choose the equipment which has enough allowance for the current rating.

To measure and display the output voltage and output current of the inverter, it is recommended to use the terminal AM-5, FM-SD output function of the inverter.

## Disuse of power factor improving capacitor (power capacitor)

The power factor improving capacitor and surge suppressor on the inverter output side may be overheated or damaged by the harmonic components of the inverter output. Also, since an excessive current flows in the inverter to activate overcurrent protection, do not install a capacitor or surge suppressor.

## Wire thickness and wiring distance

When the wiring length between the inverter and motor is long, use thick wires so that the voltage drop of the main circuit cable is 2% or less especially at low frequency output. (A selection example for the wiring distance of 20m is shown on page 31)

Especially at a long wiring distance, the maximum wiring length should be within 500m since the overcurrent protection function may be misactivated by the influence of a charging current due to the stray capacitances of the wiring.

(The overall wiring length for connection of multiple motors should be within 500m.)

The wiring length should be 100m maximum for vector control. Use the recommended connection cable when installing the operation panel away from the inverter unit or when connecting the parameter unit.

For remote operation via analog signal, wire the control cable between the operation box or operation signal and inverter within 30m and away from the power circuits (main circuit and relay sequence circuit) to prevent induction from other devices.

When using the external potentiometer instead of the parameter unit to set the frequency, use a shielded or twisted cable, and do not earth (ground) the shield, but connect it to terminal 5 as shown below.

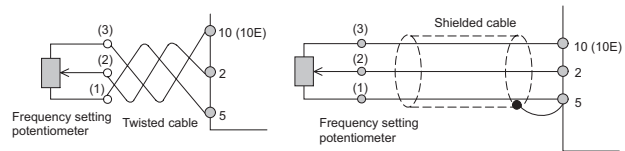

## Earth (Ground)

When the inverter is run in the low acoustic noise mode, more leakage currents occur than in the non-low acoustic noise mode due to high-speed switching operation. Be sure to use the inverter and motor after grounding (earthing) them. In addition, always use the earth (ground) terminal of the inverter to earth (ground) the inverter. (Do not use the case and chassis)

## Noise

When performing low-noise operation at higher carrier frequency, electromagnetic noise tends to increase. Therefore, refer to the following measure example and consider taking the measures. Depending on the installation condition, the inverter may be affected by noise in a non-low noise (initial) status.

- The noise level can be reduced by decreasing the carrier frequency (Pr.72).
- As measures against AM radio broadcasting noise and sensor malfunction, common mode filter produces an effect.
- As measures against induction noise from the power cable of the inverter, providing a distance of 30cm (at least 10cm) or more and using a twisted pair shielded cable as a signal cable produces an effect. Do not earth (ground) shield but connect it to signal common cable.

### Example of noise reduction techniques

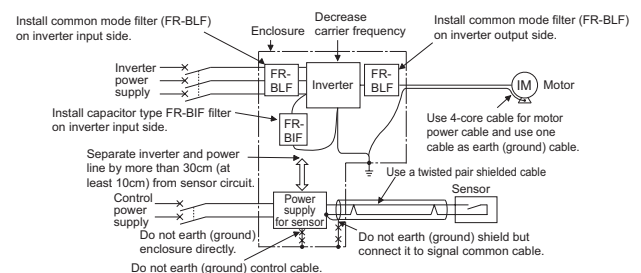

## Leakage currents

Capacitances exist between the inverter I/O cables, other cables and earth and in the motor, through which a leakage current flows. Since its value depends on the static capacitances, carrier frequency, etc., low acoustic noise operation at the increased carrier frequency of the inverter will increase the leakage current. Therefore, take the following measures. Select the earth leakage current breaker according to its rated sensitivity current, independently of the carrier frequency setting.

### To-earth (ground) leakage currents

Type	Influence and Measures
<b>Influence and measures</b>	<ul style="list-style-type: none"> <li>Leakage currents may flow not only into the inverter's own line but also into the other lines through the earth (ground) cable, etc. These leakage currents may operate earth (ground) leakage circuit breakers and earth leakage relays unnecessarily.</li> <li>Countermeasures</li> <li>If the carrier frequency setting is high, decrease the <i>Pr. 72 PWM frequency selection</i> setting. Note that motor noise increases. Select <i>Pr. 240 Soft-PWM operation selection</i> to make the sound inoffensive.</li> <li>By using earth leakage circuit breakers designed for harmonic and surge suppression in the inverter's own line and other line, operation can be performed with the carrier frequency kept high (with low noise).</li> </ul>
<b>Undesirable current path</b>	

### Line leakage current

Type	Influence and Measures
<b>Influence and measures</b>	<ul style="list-style-type: none"> <li>This leakage current flows via a static capacitance between the inverter output cables.</li> <li>The external thermal relay may be operated unnecessarily by the harmonics of the leakage current. When the wiring length is long (50m or more) for the 400V class small-capacity model (7.5kW or less), the external thermal relay is likely to operate unnecessarily because the ratio of the leakage current to the rated motor current increases.</li> <li>Countermeasures</li> <li>Use <i>Pr.9 Electronic thermal O/L relay</i>.</li> <li>If the carrier frequency setting is high, decrease the <i>Pr. 72 PWM frequency selection</i> setting. Note that motor noise increases. Select <i>Pr.240 Soft-PWM operation selection</i> to make the sound inoffensive. To ensure that the motor is protected against line-to-line leakage currents, it is recommended to use a temperature sensor to directly detect motor temperature.</li> </ul>
<b>Undesirable current path</b>	

### ● Harmonic suppression guideline in Japan

Harmonic currents flow from the inverter to a power receiving point via a power transformer. The harmonic suppression guideline was established to protect other consumers from these outgoing harmonic currents.

The three-phase 200V input specifications 3.7kW or less are previously covered by "Harmonic suppression guideline for household appliances and general-purpose products" and other models are covered by "Harmonic suppression guideline for consumers who receive high voltage or special high voltage". However, the general-purpose inverter has been excluded from the target products covered by "Harmonic suppression guideline for household appliances and general-purpose products" in January 2004. Later, this guideline was repealed on September 6, 2004. All capacities of all models are now target products of "Harmonic suppression guideline for consumers who receive high voltage or special high voltage".

- "Harmonic suppression guideline for consumers who receive high voltage or special high voltage"

This guideline sets forth the maximum values of harmonic currents outgoing from a high-voltage or especially high-voltage consumer who will install, add or renew harmonic generating equipment. If any of the maximum values is exceeded, this guideline requires that consumer to take certain suppression measures.

For compliance to the "Harmonic suppression guideline for consumers who receive high voltage or special high voltage"

Input Power Supply	Target Capacity	Measures
Three-phase 200V	All capacities	Make a judgment based on "Harmonic suppression guideline for consumers who receive high voltage or special high voltage" issued by the Japanese Ministry of Economy, Trade and Industry (formerly Ministry of International Trade and Industry) in September 1994 and take measures if necessary. For calculation method of power supply harmonics, refer to materials below. Reference materials · "Harmonic suppression measures of the inverter" Jan. 2004 JEMA :Japan Electrical Manufacturer's Association · "Calculation method of harmonic current of the general-purpose inverter used by specific consumers" JEM-TR201 (revised in Dec. 2003): Japan Electrical Manufacturer's Association
Three-phase 400V		

### ● Calculation of outgoing harmonic current

Outgoing harmonic current = fundamental wave current (value converted from received power voltage) × operation ratio × harmonic content

- Operation ratio: Operation ratio = actual load factor × operation time ratio during 30 minutes
- Harmonic content: found in Table 1.

Table 1: Harmonic content (values of the fundamental current is 100%)

Reactor	5th	7th	11th	13th	17th	19th	23rd	25th
Used (AC side)	38	14.5	7.4	3.4	3.2	1.9	1.7	1.3

\* The FR-A701 series has a built-in AC reactor corresponding to the FR-HAL.

Table 2: Rated capacities and outgoing harmonic currents of inverter-driven motors

Applicable Motor (kW)	Rated Current [A]		Fundamental Wave Current Converted from 6.6kV (mA)	Rated Capacity (kVA)	Outgoing Harmonic Current Converted from 6.6kV (mA)							
	200V	400V			(No reactor, 100% operation ratio)							
	5th	7th			11th	13th	17th	19th	23rd	25th		
5.5	19.1	9.55	579	6.77	220.0	83.96	42.85	19.69	18.53	11.00	9.843	7.527
7.5	25.6	12.8	776	9.07	294.9	112.5	57.42	26.38	24.83	14.74	13.19	10.09
11	36.9	18.5	1121	13.1	426.0	162.5	82.95	38.11	35.87	21.30	19.06	14.57
15	49.8	24.9	1509	17.6	573.4	218.8	111.7	51.31	48.29	28.67	25.65	19.62
18.5	61.4	30.7	1860	21.8	706.8	269.7	137.6	63.24	59.52	35.34	31.62	24.18
22	73.1	36.6	2220	25.9	843.6	321.9	164.3	75.48	71.04	42.18	37.74	28.86
30	98.0	49.0	2970	34.7	1129	430.7	219.8	101.0	95.04	56.43	50.49	38.61
37	121	60.4	3660	42.8	1391	530.7	270.8	124.4	117.1	69.54	62.22	47.58
45	147	73.5	4450	52.1	1691	645.3	329.3	151.3	142.4	84.55	75.65	57.85
55	180	89.9	5450	63.7	2071	790.3	403.3	185.3	174.4	103.6	92.65	70.85

Features  
Standard Specifications  
Outline Dimension Drawings  
Terminal Connection Diagram Terminal Specification Explanation  
Parameter List  
Protective Functions  
Options  
Instructions  
Warranty  
Inquiry

## Warranty

### 1. Gratis warranty period and coverage

#### [Gratis warranty period]

Note that an installation period of less than one year after installation in your company or your customer's premises or a period of less than 18 months (counted from the date of production) after shipment from our company, whichever is shorter, is selected.

#### [Coverage]

##### (1) Diagnosis of failure

As a general rule, diagnosis of failure is done on site by the customer.

However, Mitsubishi or Mitsubishi service network can perform this service for an agreed upon fee upon the customer's request.

There will be no charges if the cause of the breakdown is found to be the fault of Mitsubishi.

##### (2) Breakdown repairs

There will be a charge for breakdown repairs, exchange replacements and on site visits for the following four conditions, otherwise there will be a charge.

- 1) Breakdowns due to improper storage, handling, careless accident, software or hardware design by the customer.
- 2) Breakdowns due to modifications of the product without the consent of the manufacturer.
- 3) Breakdowns resulting from using the product outside the specified specifications of the product.
- 4) Breakdowns that are outside the terms of warranty.

Since the above services are limited to Japan, diagnosis of failures, etc. are not performed abroad.

If you desire the after service abroad, please register with Mitsubishi. For details, consult us in advance.

### 2. Exclusion of opportunity loss from warranty liability

Regardless of the gratis warranty term, compensation to opportunity losses incurred to your company or your customers by failures of Mitsubishi products and compensation for damages to products other than Mitsubishi products and other services are not covered under warranty.

### 3. Repair period after production is discontinued

Mitsubishi shall accept product repairs for seven years after production of the product is discontinued.

### 4. Terms of delivery

In regard to the standard product, Mitsubishi shall deliver the standard product without application settings or adjustments to the customer and Mitsubishi is not liable for on site adjustment or test run of the product.

## International FA Center

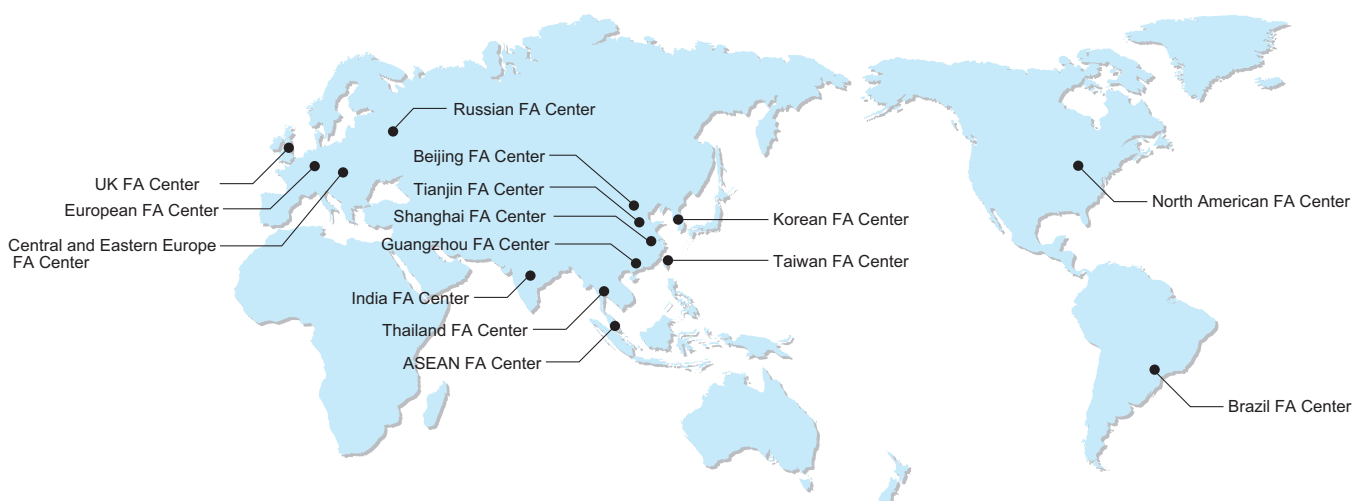

### ●North American FA Center

MITSUBISHI ELECTRIC AUTOMATION, INC.  
500 Corporate Woods Parkway, Vernon Hills, IL 60061 U.S.A  
TEL. +1-847-478-2100 FAX. +1-847-478-0327

### ●Korean FA Center

MITSUBISHI ELECTRIC AUTOMATION KOREA CO., LTD.  
B1F,2F, 1480-6, Gayang-Dong, Gangseo-Gu, Seoul, 157-200, Korea  
TEL. +82-2-3660-9607 FAX. +82-2-3664-0475

### ●Taiwan FA Center

SETSUYO ENTERPRISE CO., LTD.  
6F No.105, Wu Kung 3rd RD, Wu-Ku Hsiang Taipei Hsien, 248, Taiwan  
TEL. +886-2-2299-2499 FAX. +886-2-2299-2509

### ●Beijing FA Center

MITSUBISHI ELECTRIC AUTOMATION (CHINA) LTD. BEIJING OFFICE  
9F Office Tower 1, Henderson Center, 18 Jianguomennei Avenue, Dongcheng District, Beijing, China 100005  
TEL. +86-10-6518-8830 FAX. +86-10-6518-8030

### ●Russian FA Center

MITSUBISHI ELECTRIC EUROPE B.V.  
-Representative Office in St. Petersburg  
Sverdlovskaya Emb.,44, Bld Sch, BC "Benua";195027, St.Petersburg, Russia  
TEL. +7-812-633-3496 FAX. +7-812-633-3499

### ●Tianjin FA Center

MITSUBISHI ELECTRIC AUTOMATION (CHINA) LTD. TIANJIN OFFICE  
B-2 801/802, Youyi Building, No.50 Youyi Road, Hexi District, Tianjin, China 300061  
TEL +86-22-2813-1015 FAX. +86-22-2813-1017

### ●Shanghai FA Center

MITSUBISHI ELECTRIC AUTOMATION (CHINA) LTD.  
4/F Zhi Fu Plazz, No.80 Xin Chang Road, Shanghai, China 200003  
TEL. +86-21-6121-2460 FAX. +86-21-6121-2424

### ●Guangzhou FA Center

MITSUBISHI ELECTRIC AUTOMATION (CHINA) LTD. GUANGZHOU OFFICE  
Rm.1609, North Tower, The Hub Center, No.1068, Xing Gang East Road, Haizhu District, Guangzhou, China 510335  
TEL. +86-20-8923-6713 FAX. +86-20-8923-6715

### ●India FA Center

Mitsubishi Electric Asia Pvt. Ltd. Gurgaon Branch  
2nd Floor, DLF Building No.9B, DLF Cyber City Phase III, Gurgaon 122002, Haryana, India  
TEL. +91-124-4630300 FAX. +91-124-4630399

### ●Thailand FA Center

MITSUBISHI ELECTRIC AUTOMATION (THAILAND) CO., LTD.  
Bang-Chan Industrial Estate No.111, Soi Serithai 54, T.Kannayao, A.Kannayao, Bangkok 10230  
TEL. +66-2-906-3238 FAX. +66-2-906-3239

### ●ASEAN FA Center

MITSUBISHI ELECTRIC ASIA PTE, LTD.  
307 Alexandra Road #05-01/02, Mitsubishi Electric Building, Singapore 159943  
TEL. +65-6470-2480 FAX. +65-6476-7439

### ●European FA Center

MITSUBISHI ELECTRIC EUROPE B. V. GERMAN BRANCH  
Gothaer Strasse 8, D-40880 Ratingen, Germany  
TEL. +49-2102-486-0 FAX. +49-2102-486-1120

### ●UK FA Center

MITSUBISHI ELECTRIC EUROPE B. V. UK BRANCH  
Travellers Lane, Hatfield, Hertfordshire, AL10 8XB, U.K.  
TEL. +44-1707-276100 FAX. +44-1707-278695

### ●Central and Eastern Europe FA Center

MITSUBISHI ELECTRIC EUROPE B.V. CZECH BRANCH  
Avenir Business Park, Radlicka 714/113a, 158 00 Praha 5, Czech Republic  
TEL. +420-251-551-470 FAX. +420-251-551-471

### ●Brazil FA Center

MELCO-TEC Representacao Comercial e Assessoria Tecnica Ltda.  
Av. Paulista 1439, conj.74, Bela Vista CEP: 01311-200 Sao Paulo-SP-Brazil  
TEL. +55-11-3146-2202 FAX. +55-11-3146-2217

Features

Standard Specifications

Outline Dimension Drawings

Terminal Connection Diagram Terminal Specification Explanation

Parameter List

Protective Functions

Options

Instructions

Warranty

Inquiry

 **Safety Warning**

To ensure proper use of the products listed in this catalog, please be sure to read the instruction manual prior to use.

Mitsubishi Electric Corporation Nagoya Works is a factory certified for ISO 14001 (standards for environmental management systems).



for a greener tomorrow

Eco Changes is the Mitsubishi Electric Group's environmental statement, and expresses the Group's stance on environmental management. Through a wide range of businesses, we are helping contribute to the realization of a sustainable society.



**MITSUBISHI ELECTRIC CORPORATION**

HEAD OFFICE: TOKYO BLDG., 2-7-3, MARUNOUCHI, CHIYODA-KU, TOKYO 100-8310, JAPAN  
[www.MitsubishiElectric.co.jp/melfansweb](http://www.MitsubishiElectric.co.jp/melfansweb)