

## 2-2 EG Series - Low Profile Ball Type Linear Guideway

### 2-2-1 Features of the EG Series Linear Guideway

The design of the EG series offers a low profile, high load capacity, and high rigidity. It also features an equal load rating in all four directions and self-aligning capability to absorb installation-error, allowing for higher accuracies. Additionally, the lower assembly height and the shorter length make the EG series more suitable for high-speed, automation machines and applications where space is limited.

The retainer is designed to hold the balls in the block even when it is removed from the rail.

### 2-2-2 Construction of EG Series

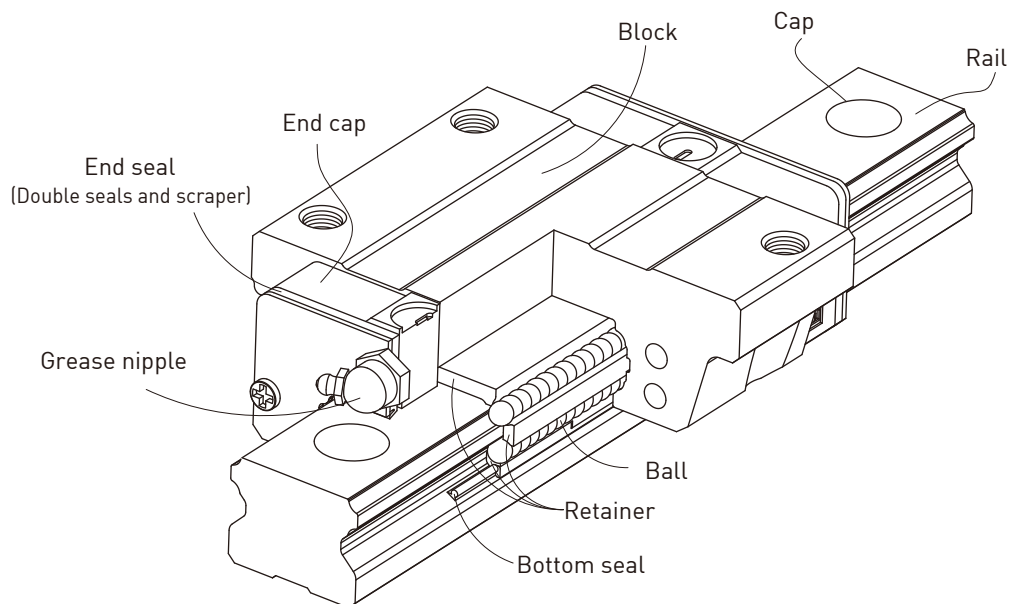

- Rolling circulation system: Block, rail, end cap and retainer
- Lubrication system: Grease nipple and piping Joint
- Dust protection system: End seal, bottom seal, cap and scraper

### 2-2-3 Model Number of EG Series

EG series linear guideways are classified into non-interchangeable and interchangeable types. The sizes of these two types are the same as one another. The main difference is that the interchangeable type of blocks and rails can be freely exchanged and they can maintain P-class accuracy. Because of strict dimensional control, the interchangeable type linear guideways are a wise choice for customers when rails do not need to be matched for an axis. The model number of the EG series identifies the size, type, accuracy class, preload class, etc.

# EG Series

## Low Profile Ball Type

### (1) Non-interchangeable type

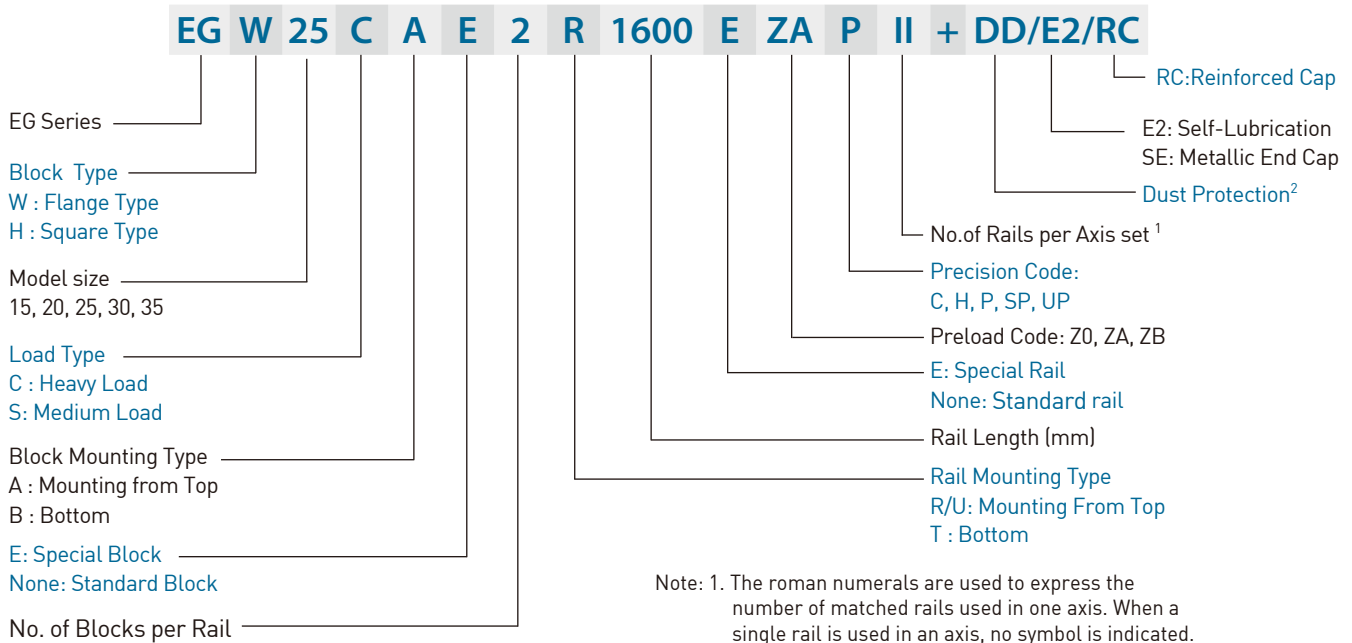

Note: 1. The roman numerals are used to express the number of matched rails used in one axis. When a single rail is used in an axis, no symbol is indicated.  
2. No symbol indicates standard protection (end seal and bottom seal).  
ZZ : End seal, bottom seal and scraper  
KK: Double seals, bottom seal and scraper.  
DD: Double seals and bottom seal

### (2) Interchangeable type

#### Model Number of EG Block

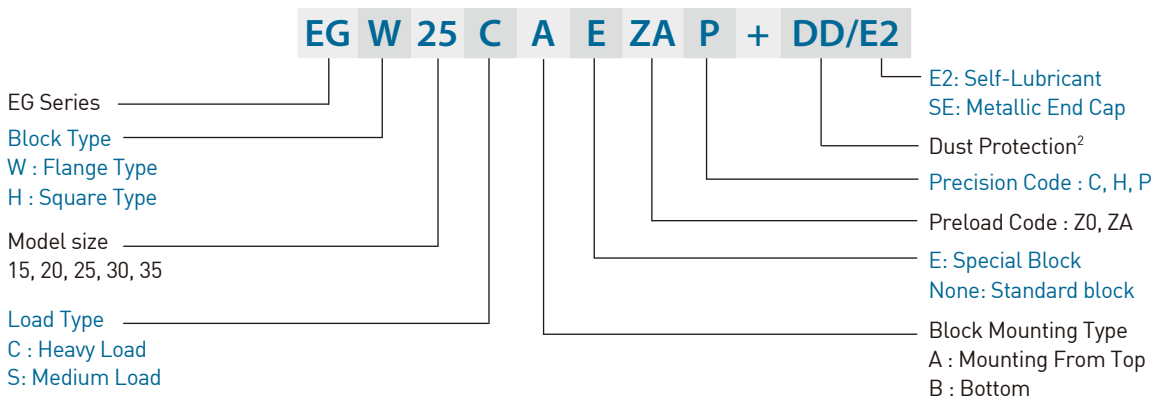

#### Model Number of EG Rail

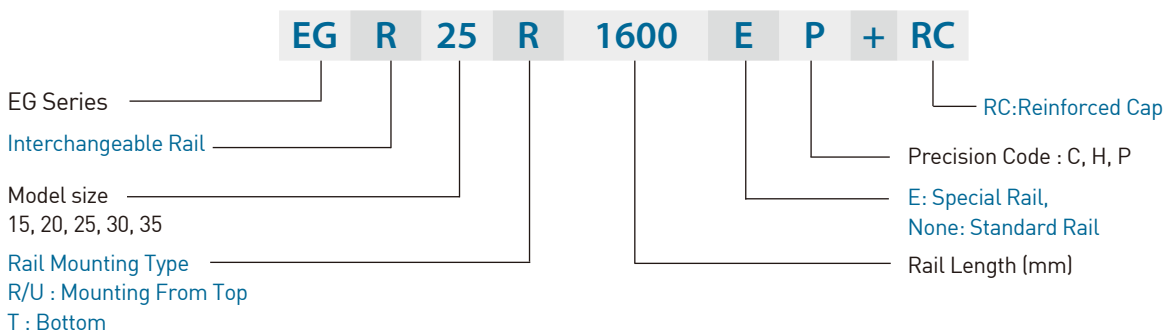

## 2-2-4 Types

### (1) Block types

HIWIN offers two types of linear guideways, flange and square types.

Table 2-2-1 Block Types

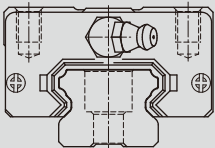
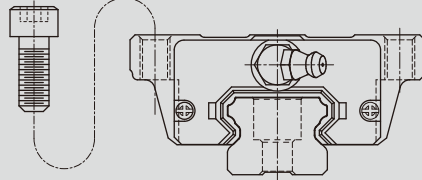
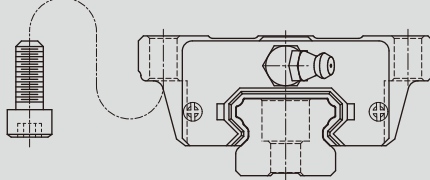
Type	Model	Shape	Height (mm)	Rail Length (mm)	Main Applications
Square	EGH-SA EGH-CA		24	100	<ul style="list-style-type: none"> <li>○ Automation devices</li> <li>○ High-speed transportation equipment</li> <li>○ Precision measuring equipment</li> <li>○ Semiconductor manufacturing equipment</li> </ul>
			↓	↓	
48	4000				
Flange	EGW-SA EGW-CA		24	100	
			↓	↓	
			48	4000	
			EGW-SB EGW-CB		24
↓	↓				
48	4000				

\*Please refer to the chapter 2-2-13 for the dimensional detail.

### (2) Rail types

Besides the standard top mounting type, HIWIN also offers bottom mounting type rails.

Table 2-2-2 Rail Types

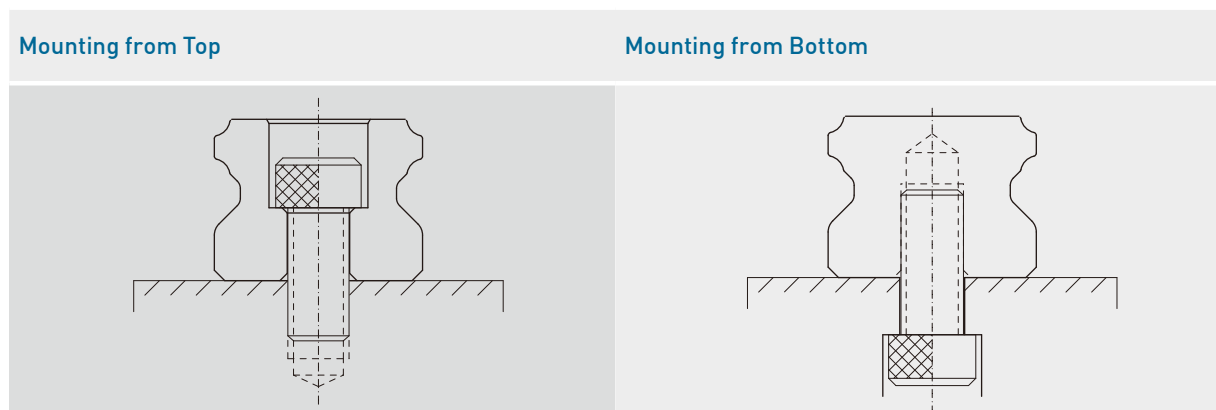

## EG Series

### Low Profile Ball Type

#### 2-2-5 Accuracy

The accuracy of the EG series can be classified into 5 classes: normal(C), high(H), precision(P), super precision(SP), and ultra precision(UP). Choose the class by referencing the accuracy of selected equipment.

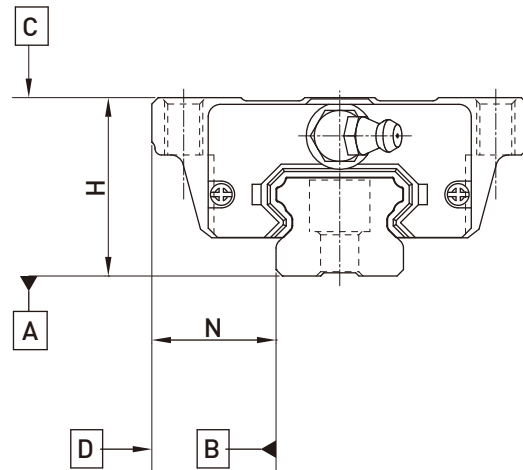

#### (1) Accuracy of non-interchangeable guideways

Table 2-2-3 Accuracy Standards

Unit: mm

Item	EG - 15, 20				
	Normal (C)	High (H)	Precision (P)	Super Precision (SP)	Ultra Precision (UP)
Dimensional tolerance of height H	± 0.1	± 0.03	0 - 0.03	0 - 0.015	0 - 0.008
Dimensional tolerance of width N	± 0.1	± 0.03	0 - 0.03	0 - 0.015	0 - 0.008
Variation of height H	0.02	0.01	0.006	0.004	0.003
Variation of width N	0.02	0.01	0.006	0.004	0.003
Running parallelism of block surface C to surface A	See Table 2-2-7				
Running parallelism of block surface D to surface B	See Table 2-2-7				

Table 2-2-4 Accuracy Standards

Unit: mm

Item	EG - 25, 30, 35				
	Normal (C)	High (H)	Precision (P)	Super Precision (SP)	Ultra Precision (UP)
Dimensional tolerance of height H	± 0.1	± 0.04	0 - 0.04	0 - 0.02	0 - 0.01
Dimensional tolerance of width N	± 0.1	± 0.04	0 - 0.04	0 - 0.02	0 - 0.01
Variation of height H	0.02	0.015	0.007	0.005	0.003
Variation of width N	0.03	0.015	0.007	0.005	0.003
Running parallelism of block surface C to surface A	See Table 2-2-7				
Running parallelism of block surface D to surface B	See Table 2-2-7				

## (2) Accuracy of interchangeable guideways

Table 2-2-5 Accuracy Standards

Unit: mm

Item	EG - 15, 20		
Accuracy Classes	Normal (C)	High (H)	Precision (P)
Dimensional tolerance of height H	± 0.1	± 0.03	± 0.015
Dimensional tolerance of width N	± 0.1	± 0.03	± 0.015
Variation of height H	0.02	0.01	0.006
Variation of width N	0.02	0.01	0.006
Running parallelism of block surface C to surface A	See Table 2-2-7		
Running parallelism of block surface D to surface B	See Table 2-2-7		

Table 2-2-6 Accuracy Standards

Unit: mm

Item	EG - 25, 30, 35		
Accuracy Classes	Normal (C)	High (H)	Precision (P)
Dimensional tolerance of height H	± 0.1	± 0.04	± 0.02
Dimensional tolerance of width N	± 0.1	± 0.04	± 0.02
Variation of height H	0.02	0.015	0.007
Variation of width N	0.03	0.015	0.007
Running parallelism of block surface C to surface A	See Table 2-2-7		
Running parallelism of block surface D to surface B	See Table 2-2-7		

## (3) Accuracy of running parallelism

Table 2-2-7 Accuracy of Running Parallelism

Rail Length (mm)	Accuracy (μm)				
	C	H	P	SP	UP
~ 100	12	7	3	2	2
100 ~ 200	14	9	4	2	2
200 ~ 300	15	10	5	3	2
300 ~ 500	17	12	6	3	2
500 ~ 700	20	13	7	4	2
700 ~ 900	22	15	8	5	3
900 ~ 1,100	24	16	9	6	3
1,100 ~ 1,500	26	18	11	7	4
1,500 ~ 1,900	28	20	13	8	4
1,900 ~ 2,500	31	22	15	10	5
2,500 ~ 3,100	33	25	18	11	6
3,100 ~ 3,600	36	27	20	14	7
3,600 ~ 4,000	37	28	21	15	7

# EG Series

## Low Profile Ball Type

### 2-2-6 Preload

#### (1) Definition

A preload can be applied to each guideway. Generally, a linear motion guideway has a negative clearance between the groove and balls in order to improve stiffness and maintain high precision. The figure shows that adding a preload can improve stiffness of the linear guideway. A preload no greater than ZA would be recommended for model sizes smaller than EG20. This will avoid an over-loaded condition that would affect guideway life.

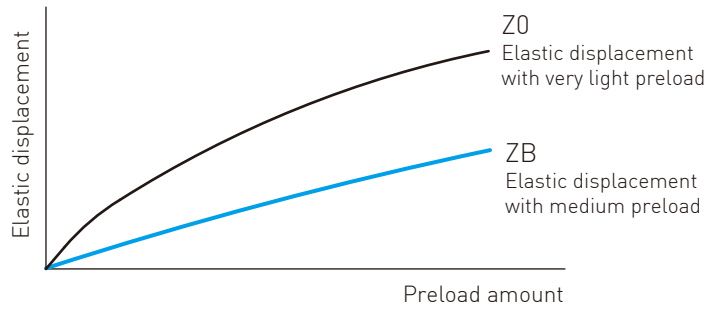

#### (2) Preload classes

HIWIN offers three standard preloads for various applications and conditions.

Table 2-2-8 Preload Classes

Class	Code	Preload	Condition
Very Light Preload	Z0	0~ 0.02C	Certain load direction, low impact, low precision required
Light Preload	ZA	0.03C~0.05C	low load and high precision required
Medium Preload	ZB	0.06C~ 0.08C	High rigidity required, with vibration and impact

Class	Interchangeable Guideway	Non-Interchangeable Guideway
Preload classes	Z0, ZA	Z0, ZA, ZB

Note: The "C" in the preload column denotes basic dynamic load rating.

#### (3) Stiffness performance

Stiffness depends on preload. The following table shows stiffness value of each size.

Table 2-2-9 Radial stiffness for EG Series

Load type	Series / Size	Stiffness (N/μm)		
		Z0	ZA	ZB
Medium load	EG 15S	87	186	246
	EG 20S	114	267	369
	EG 25S	138	307	415
	EG 30S	166	335	447
	EG 35S	189	369	492
Heavy load	EG 15C	141	323	429
	EG 20C	181	444	615
	EG 25C	219	510	668
	EG 30C	265	555	745
	EG 35C	307	615	816

## 2-2-7 Lubrication

### (1) Grease

#### ○ Grease nipple

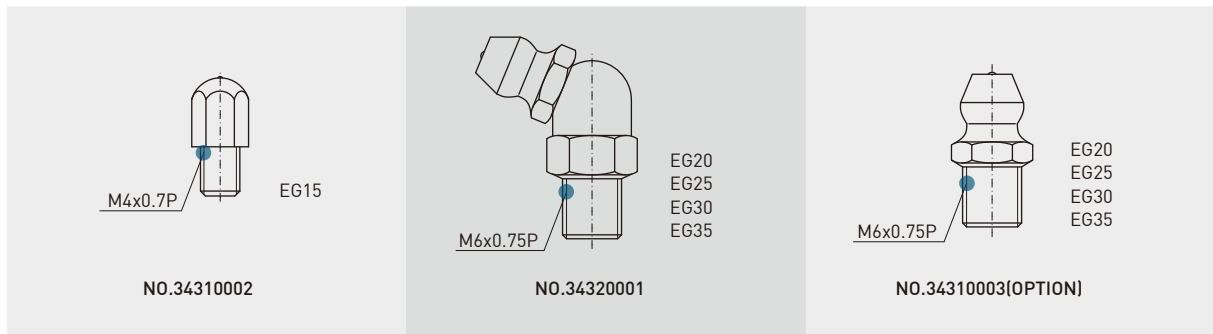

#### ○ Mounting location

The standard location of the grease fitting is at both ends of the block, the nipple may be mounted in the side or top of the block. For lateral installation, we recommend that the nipple be mounted to the non-reference side, otherwise please contact us. When lubricating from above, in the recess for the O-ring, a smaller, preformed recess can be found. Preheat the 0.8 mm diameter metal tip. Carefully open the small recess with the metal tip and pierce through it. Insert a round sealing ring into the recess. (The round sealing ring is not supplied with the block) Do not open the small recess with a drill bit this may introduce the danger of contamination. It is possible to carry out the lubrication by using the oil-piping joint.

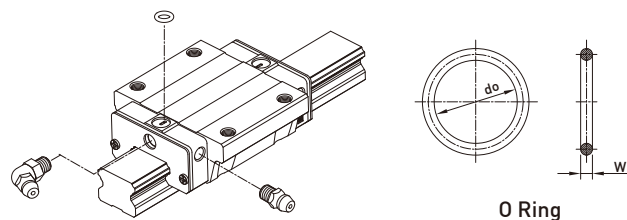
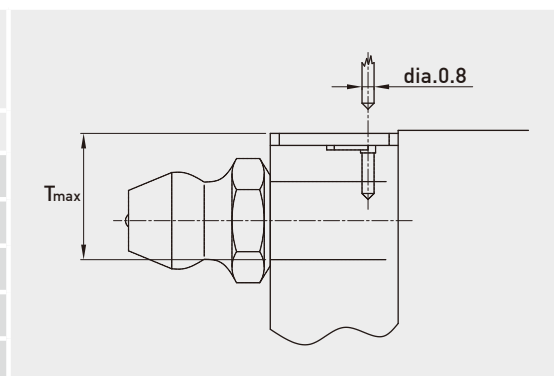

Table 2-2-10 O-Ring size and max. permissible depth for piercing

Size	O-Ring		Lube hole at top: max. permissible depth for piercing
	do(mm)	W (mm)	T <sub>max</sub> (mm)
EG15	2.5 ± 0.15	1.5 ± 0.15	6.9
EG20	4.5 ± 0.15	1.5 ± 0.15	8.4
EG25	4.5 ± 0.15	1.5 ± 0.15	10.4
EG30	4.5 ± 0.15	1.5 ± 0.15	10.4
EG35	4.5 ± 0.15	1.5 ± 0.15	10.8



## EG Series

### Low Profile Ball Type

○ The oil amount for a block filled with grease

Table 2-2-11 The oil amount for a block filled with grease

Size	Medium Load (cm <sup>3</sup> )	Heavy Load (cm <sup>3</sup> )
EG15	0.8	1.4
EG20	1.5	2.4
EG25	2.8	4.6
EG30	3.7	6.3
EG35	5.6	6.6

○ Frequency of replenishment

Check the grease every 100 km, or every 3-6 months.

(2) Oil

The recommended viscosity of oil is about 32~150cSt. If you need to use oil-type lubrication, please inform us.

○ Types of oil piping joint

<p>LF-64</p> <p>NO.97000EA1 EG15</p>	<p>LF-76</p> <p>NO.970002A1 EG20 EG25 EG30 EG35</p>	<p>LF-86</p> <p>NO.970004A1 EG20 EG25 EG30 EG35</p>
<p>SF-64</p> <p>NO.97001TA1 EG15</p>	<p>SF-76</p> <p>NO.970001A1 EG20 EG25 EG30 EG35</p>	<p>SF-86</p> <p>NO.970003A1 EG20 EG25 EG30 EG35</p>



○ Oil feeding rate

Table 2-2-12 oil feed rate

Size	feed rate (cm <sup>3</sup> /hr)	Size	feed rate (cm <sup>3</sup> /hr)
EG15	0.1	EG30	0.2
EG20	0.133	EG35	0.233
EG25	0.167		

## 2-2-8 Dust Protection Equipment

### (1) Codes of equipment

If the following equipment is needed, please indicate the code followed by the model number.

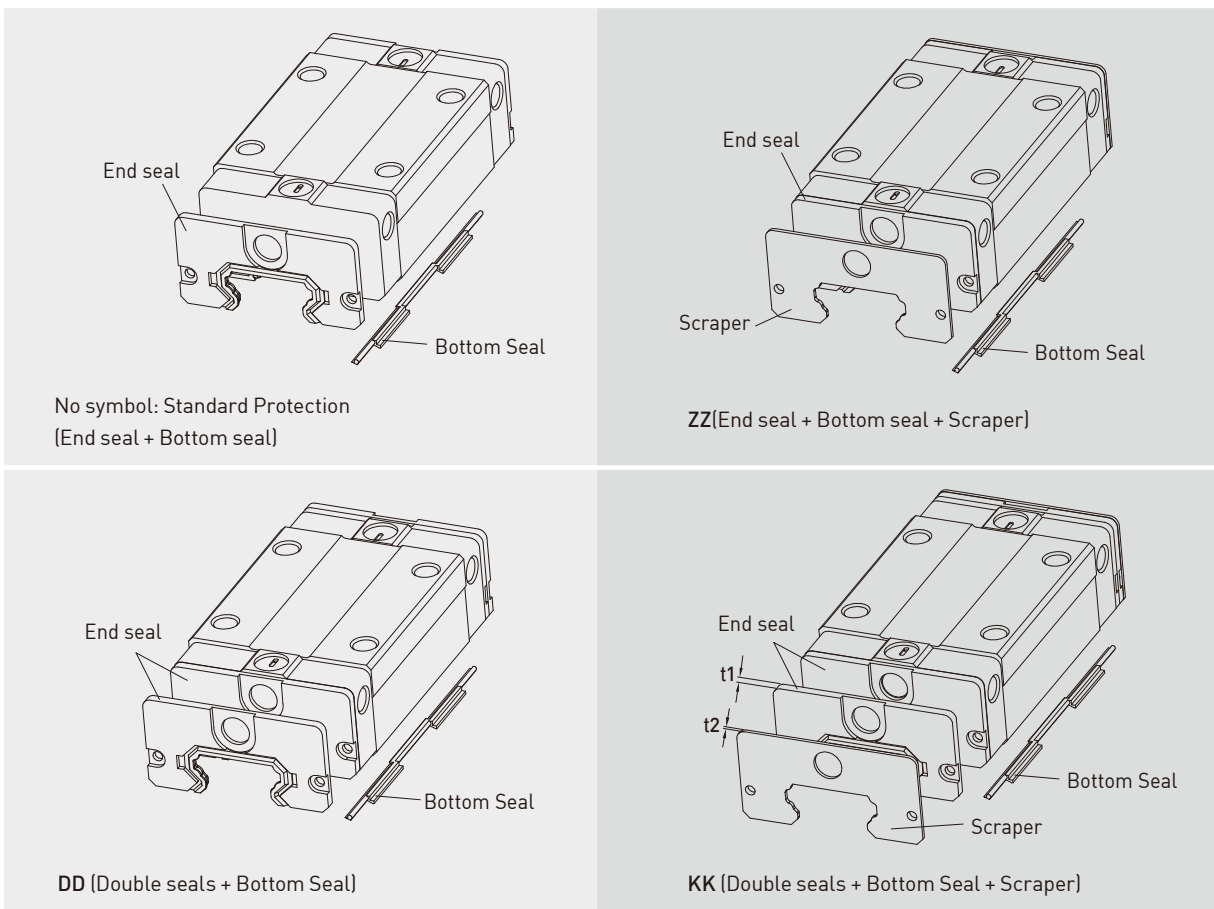

### (2) End seal and bottom seal

Protects against contaminants entering the block. Reduces potential for groove damage resulting in a reduction of life ratings.

### (3) Double seals

Removing foreign matters from the rail to prevent contaminants from entering the block.

Table 2-2-13 Dimensions of end seal

Size	Thickness (t1) (mm)	Size	Thickness (t1) (mm)
EG15 ES	2	EG30 ES	2
EG20 ES	2	EG35 ES	2
EG25 ES	2		

## EG Series

### Low Profile Ball Type

#### (4) Scraper

Clears larger contaminants, such as weld spatter and metal cuttings, from the rail. Metal scraper protects end seals from excessive damage.

Table 2-2-14 Dimensions of Scraper

Size	Thickness (t2) (mm)	Size	Thickness (t2) (mm)
EG15 SC	0.8	EG30 SC	1
EG20 SC	0.8	EG35 SC	1.5
EG25 SC	1		

#### (5) Bolt caps for rail mounting holes

Rail mounting hole caps prevent foreign matter from accumulating in the mounting holes. Caps are included with the rail package.

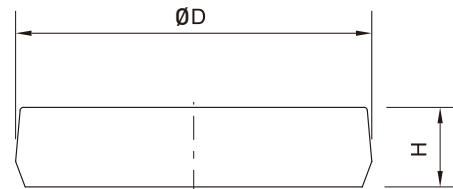

Table 2-2-15 Dimensions of Bolt Caps for Rail Mounting Holes

Rail size	Bolt size	Diameter(D) (mm)	Thickness(H) (mm)
EGR15R	M3	6.15	1.2
EGR20R	M5	9.65	2.5
EGR25R	M6	11.15	2.5
EGR30R	M6	11.15	2.5
EGR35R	M8	14.20	3.5
EGR15U	M4	7.65	1.1
EGR30U	M8	14.20	3.5

#### (6) Dimensions of block equipped with the dustproof parts

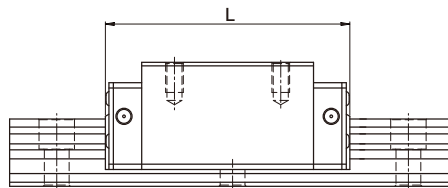

Table 2-2-16 Overall block length

unit: mm

Size	Overall block length (L)			
	SS	ZZ	DD	KK
EG15S	40.1 (42.5)	41.7 (46.1)	44.1 (46.5)	45.7 (50.1)
EG15C	56.8 (59.2)	58.4 (62.8)	60.8 (63.2)	62.4 (66.8)
EG20S	50.0 (54.0)	51.6 (57.6)	54.0 (58.0)	55.6 (61.6)
EG20C	69.1 (73.1)	70.7 (76.7)	73.1 (77.1)	74.7 (80.7)
EG25S	59.1 (63.1)	61.1 (67.1)	63.1 (67.1)	65.1 (71.1)
EG25C	82.6 (86.6)	84.6 (90.6)	86.6 (90.6)	88.6 (94.6)
EG30S	69.5 (73.5)	71.5 (77.5)	73.5 (77.5)	75.5 (81.5)
EG30C	98.1 (102.1)	100.1 (106.1)	102.1 (106.1)	104.1 (110.1)
EG35S	75.0 (79.0)	78.0 (84.0)	79.0 (83.0)	82.0 (88.0)
EG35C	108.0 (112.0)	111.0 (117.0)	112.0 (116.0)	115.0 (121.0)

Note : The marking of “( )” denotes the maximum block length with screws, lips of end seals, etc.

## 2-2-9 Friction

The maximum value of resistance per end seal are as shown in the table.

Table 2-2-17 Seal Resistance

Size	Resistance N (kgf)
EG15	0.98 (0.1)
EG20	0.98 (0.1)
EG25	0.98 (0.1)
EG30	1.47 (0.15)
EG35	1.96 (0.2)

Note: 1kgf=9.81N

## 2-2-10 Mounting Surface Accuracy Tolerance

Because of the circular-arc contact design, the EG linear guideway can withstand surface-error installation and deliver smooth linear motion. When the mounting surface meets the accuracy requirements of the installation, the high accuracy and rigidity of the guideway will be obtained without any difficulty. For faster installation and smoother movement, HIWIN offers a preload with normal clearance because of its ability to absorb higher deviations in mounting surface inaccuracies.

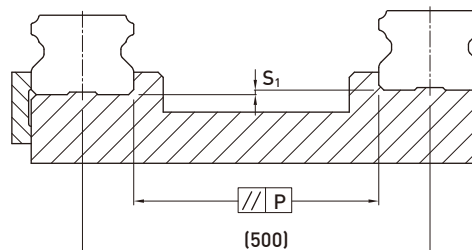

Table 2-2-18 Max. Parallelism Tolerance (P)

unit:  $\mu\text{m}$

Size	Preload classes		
	Z0	ZA	ZB
EG15	25	18	-
EG20	25	20	18
EG25	30	22	20
EG30	40	30	27
EG35	50	35	30

Table 2-2-19 Max. Tolerance of Reference Surface Height ( $S_1$ )

unit:  $\mu\text{m}$

Size	Preload classes		
	Z0	ZA	ZB
EG15	130	85	-
EG20	130	85	50
EG25	130	85	70
EG30	170	110	90
EG35	210	150	120

## EG Series

### Low Profile Ball Type

#### 2-2-11 Cautions for Installation

##### (1) Shoulder heights and chamfers

Improper shoulder heights and chamfers of mounting surfaces will cause deviations in accuracy and rail or block interference with the chamfered part.

When recommended shoulder heights and chamfers are used, problems with installation accuracy should be eliminated.

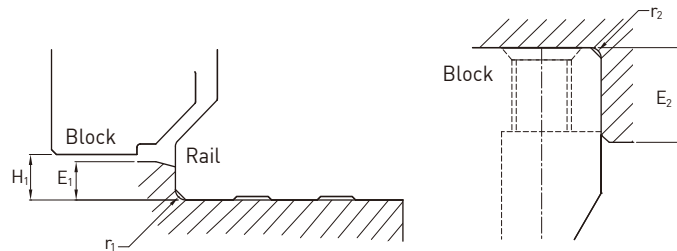

Table 2-2-20 Shoulder Heights and Chamfers

unit: mm

Size	Max. radius of fillets $r_1$ (mm)	Max. radius of fillets $r_2$ (mm)	Shoulder height of the rail $E_1$ (mm)	Shoulder height of the block $E_2$ (mm)	Clearance under block $H_1$ (mm)
EG15	0.5	0.5	2.7	5.0	4.5
EG20	0.5	0.5	5.0	7.0	6.0
EG25	1.0	1.0	5.0	7.5	7.0
EG30	1.0	1.0	7.0	7.0	10.0
EG35	1.0	1.0	7.5	9.5	11.0

##### (2) Tightening Torque of Bolts for Installation

Improperly tightened mounting bolts will seriously affect the accuracy of linear guide installations. The following tightening torques for different sizes of bolts are recommended.

Table 2-2-21 Tightening Torque

Size	Bolt size	Torque N-cm(kgf-cm)		
		Iron	Casting	Aluminum
EG 15	M3×0.5P×16L	186 (19)	127 (13)	98 (10)
EG 20	M5×0.8P×16L	883 (90)	588 (60)	441 (45)
EG 25	M6×1P×20L	1373 (140)	921 (94)	686 (70)
EG 30	M6×1P×25L	1373 (140)	921 (94)	686 (70)
EG 35	M8×1.25P×25L	3041 (310)	2010 (205)	1470 (150)

Note: 1 kgf = 9.81 N

## 2-2-12 Standard and Maximum Lengths of Rail

HIWIN offers a number of standard rail lengths. Standard rail lengths feature end mounting hole placements set to predetermined values [E]. For non-standard rail lengths, be sure to specify the E-value to be no greater than 1/2 the pitch (P) dimension. An E-value greater than this will result in unstable rail ends.

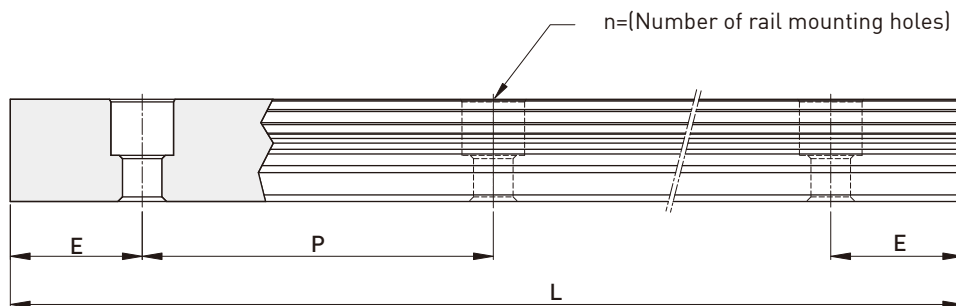

$$L = (n - 1) \times P + 2 \times E \quad \dots \dots \dots \text{Eq.2.2}$$

- L : Total length of rail (mm)
- n : Number of mounting holes
- P : Distance between any two holes (mm)
- E : Distance from the center of the last hole to the edge (mm)

Table 2-2-22 Rail Standard Length and Max. Length

unit: mm

Item	EGR15	EGR20	EGR25	EGR30	EGR35
Standard Length L(n)	160 (3)	220 (4)	220 (4)	280 (4)	280 (4)
	220 (4)	280 (5)	280 (5)	440 (6)	440 (6)
	280 (5)	340 (6)	340 (6)	600 (8)	600 (8)
	340 (6)	460 (8)	460 (8)	760 (10)	760 (10)
	460 (8)	640 (11)	640 (11)	1,000 (13)	1,000 (13)
	640 (11)	820 (14)	820 (14)	1,640 (21)	1,640 (21)
	820 (14)	1,000 (17)	1,000 (17)	2,040 (26)	2,040 (26)
		1,240 (21)	1,240 (21)	2,520 (32)	2,520 (32)
	1,600 (27)	1,600 (27)	3,000 (38)	3,000 (38)	
Pitch (P)	60	60	60	80	80
Distance to End (E <sub>s</sub> )	20	20	20	20	20
Max. Standard Length	4,000(67)	4,000 (67)	4,000 (67)	3,960 (50)	3,960 (50)
Max. Length	4,000	4,000	4,000	4,000	4,000

- Note :
1. Tolerance of E value for standard rail is 0.5--0.5 mm. Tolerance of E value for jointed rail is 0--0.3 mm.
  2. Maximum standard length means the max. rail length with standard E value on both sides.
  3. If different E value is needed, please contact HIWIN.

# EG Series

## Low Profile Ball Type

### 2-2-13 Dimensions for HIWIN EG Series

#### (1) EGH-SA / EGH-CA

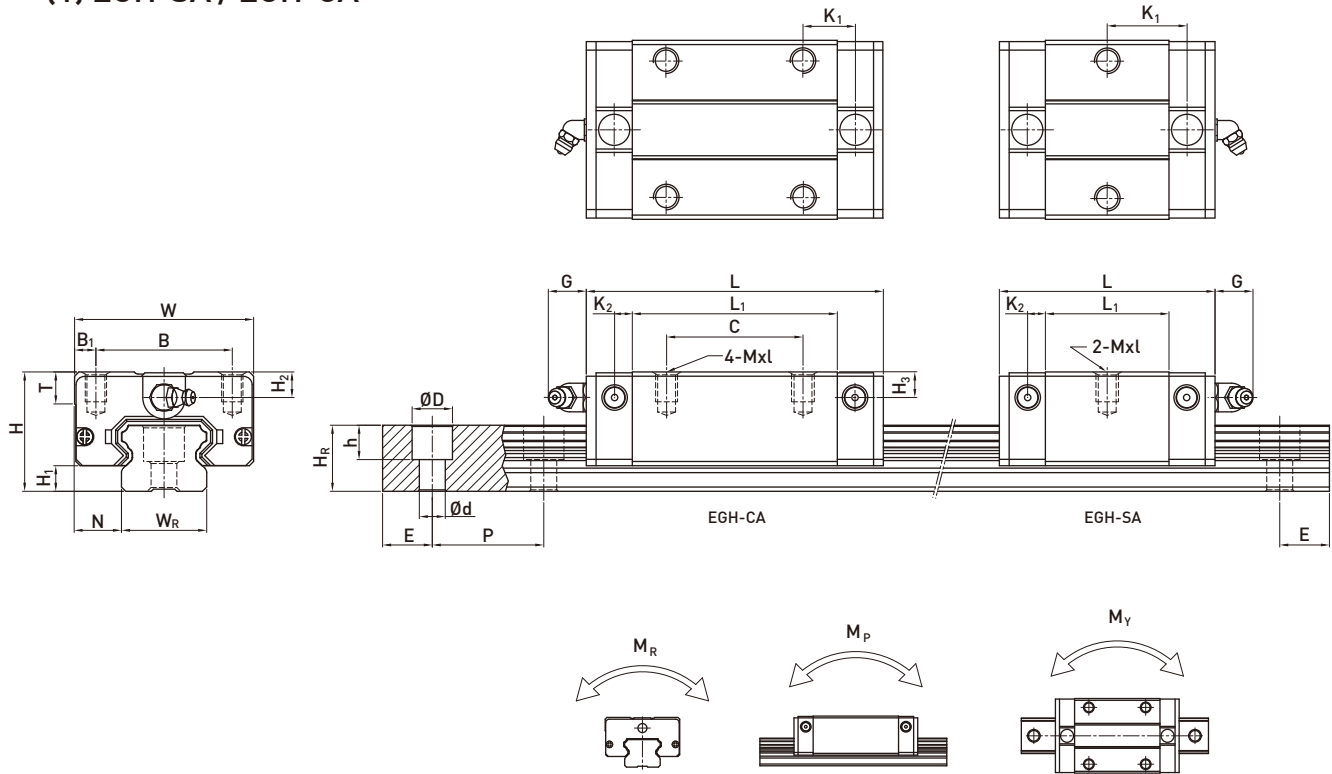

Model No.	Dimensions of Assembly (mm)			Dimensions of Block (mm)													Dimensions of Rail (mm)					Mounting Bolt for Rail (mm)	Basic Dynamic Load Rating C(kN)	Basic Static Load Rating C <sub>0</sub> (kN)	Static Rated Moment			Weight				
	H	H <sub>1</sub>	N	W	B	B <sub>1</sub>	C	L <sub>1</sub>	L	K <sub>1</sub>	K <sub>2</sub>	G	Mxl	T	H <sub>2</sub>	H <sub>3</sub>	W <sub>R</sub>	H <sub>R</sub>	D	h	d				P	E	M <sub>R</sub>	M <sub>P</sub>	M <sub>Y</sub>	Block	Rail	
	mm	mm	mm	mm	mm	mm	mm	mm	mm	mm	mm	mm	mm	mm	mm	mm	mm	mm	mm	mm	mm				mm	mm	mm	kN-m	kN-m	kN-m	kg	kg/m
EGH15SA	24	4.5	9.5	34	26	4	-	23.1	40.1	14.8	-	3.5	5.7	M4x6	6	5.5	6	15	12.5	6	4.5	3.5	60	20	M3x16	5.35	9.40	0.08	0.04	0.04	0.09	1.25
EGH15CA							26	39.8	56.8	10.15															7.83	16.19	0.13	0.10	0.10	0.15		
EGH20SA	28	6	11	42	32	5	-	29	50	18.75	-	4.15	12	M5x7	7.5	6	6	20	15.5	9.5	8.5	6	60	20	M5x16	7.23	12.74	0.13	0.06	0.06	0.15	2.08
EGH20CA							32	48.1	69.1	12.3																				10.31	21.13	
EGH25SA	33	7	12.5	48	35	6.5	-	35.5	59.1	21.9	-	4.55	12	M6x9	8	8	8	23	18	11	9	7	60	20	M6x20	11.40	19.50	0.23	0.12	0.12	0.25	2.67
EGH25CA							35	59	82.6	16.15																					16.27	
EGH30SA	42	10	16	60	40	10	-	41.5	69.5	26.75	-	6	12	M8x12	9	8	9	28	23	11	9	7	80	20	M6x25	16.42	28.10	0.40	0.21	0.21	0.45	4.35
EGH30CA							40	70.1	98.1	21.05																						
EGH35SA	48	11	18	70	50	10	-	45	75	28.5	-	7	12	M8x12	10	8.5	8.5	34	27.5	14	12	9	80	20	M8x25	22.66	37.38	0.56	0.31	0.31	0.74	6.14
EGH35CA							50	78	108	20																						

Note : 1 kgf = 9.81 N

(2) EGW-SA / EGW-CA

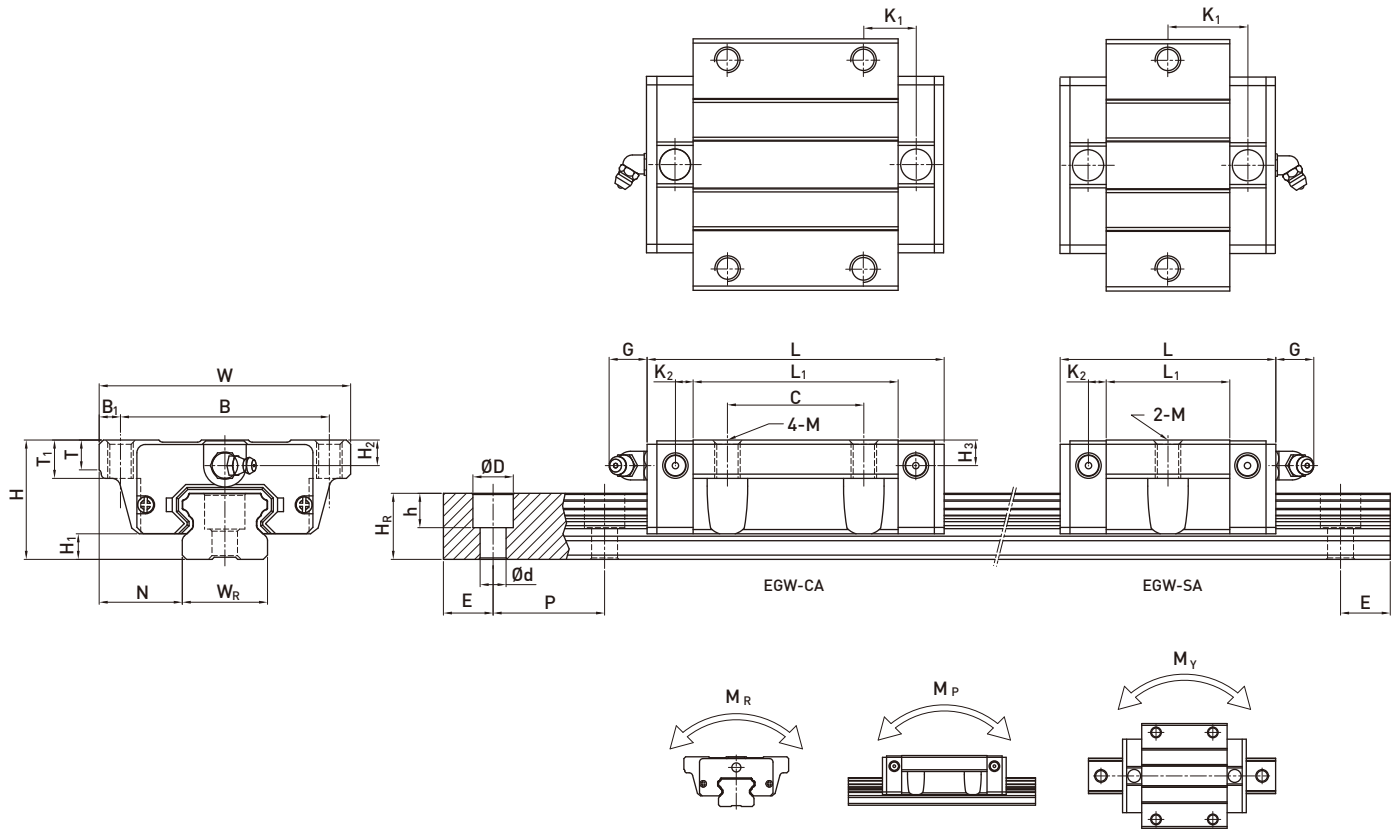

Model No.	Dimensions of Assembly (mm)		Dimensions of Block (mm)															Mounting Bolt for Rail (mm)	Basic Dynamic Load Rating C(kN)	Basic Static Load Rating C <sub>0</sub> (kN)	Static Rated Moment			Weight										
	H	H <sub>1</sub>	N	W	B	B <sub>1</sub>	C	L <sub>1</sub>	L	K <sub>1</sub>	K <sub>2</sub>	G	M	T	T <sub>1</sub>	H <sub>2</sub>	H <sub>3</sub>				W <sub>R</sub>	H <sub>R</sub>	D	h	d	P	E	C(kN)	C <sub>0</sub> (kN)	M <sub>R</sub>	M <sub>P</sub>	M <sub>V</sub>	Block	Rail
																														kN-m	kN-m	kN-m	kg	kg/m
EGW15SA	24	4.5	18.5	52	41	5.5	-	23.1	40.1	14.8	3.5	5.7	M5	5	7	5.5	6	15	12.5	6	4.5	3.5	60	20	M3x16	5.35	9.40	0.08	0.04	0.04	0.12	1.25		
EGW15CA							26	39.8	56.8	10.15																0.13	0.10	0.10	0.21					
EGW20SA	28	6	19.5	59	49	5	-	29	50	18.75	4.15	12	M6	7	9	6	6	20	15.5	9.5	8.5	6	60	20	M5x16	7.23	12.74	0.13	0.06	0.06	0.19	2.08		
EGW20CA							32	48.1	69.1	12.3																0.22	0.16	0.16	0.32					
EGW25SA	33	7	25	73	60	6.5	-	35.5	59.1	21.9	4.55	12	M8	7.5	10	8	8	23	18	11	9	7	60	20	M6x20	11.40	19.50	0.23	0.12	0.12	0.35	2.67		
EGW25CA							35	59	82.6	16.15																0.38	0.32	0.32	0.59					
EGW30SA	42	10	31	90	72	9	-	41.5	69.5	26.75	6	12	M10	7	10	8	9	28	23	11	9	7	80	20	M6x25	16.42	28.10	0.40	0.21	0.21	0.62	4.35		
EGW30CA							40	70.1	98.1	21.05																0.68	0.55	0.55	1.04					
EGW35SA	48	11	33	100	82	9	-	45	75	28.5	7	12	M10	10	13	8.5	8.5	34	27.5	14	12	9	80	20	M8x25	22.66	37.38	0.56	0.31	0.31	0.84	6.14		
EGW35CA							50	78	108	20																0.98	0.69	0.69	1.45					

Note : 1 kgf = 9.81 N

# EG Series

## Low Profile Ball Type

### (3) EGW-SB / EGW-CB

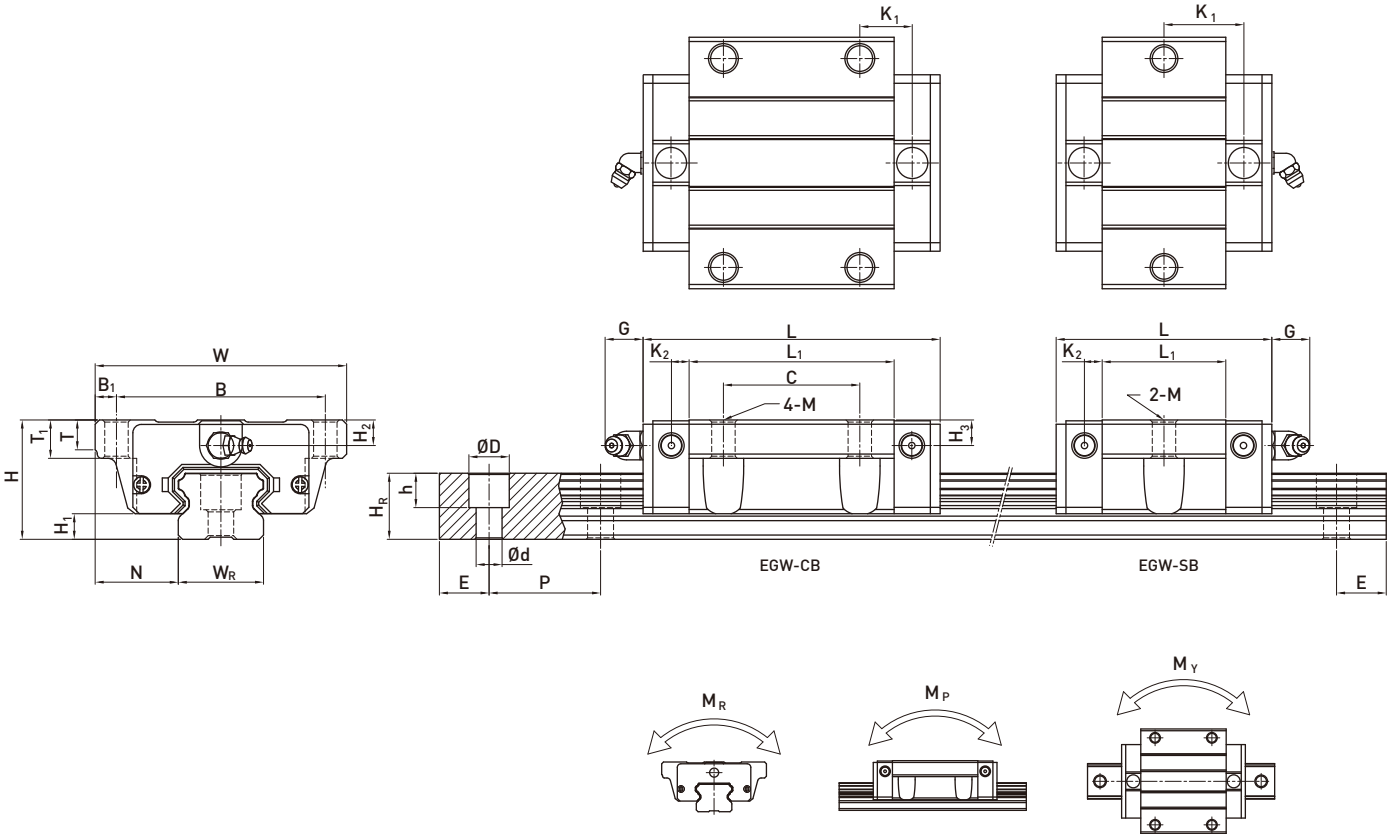

Model No.	Dimensions of Assembly (mm)		Dimensions of Block (mm)											Dimensions of Rail (mm)				Mounting Bolt for Rail (mm)	Basic Dynamic Load Rating C (kN)	Basic Static Load Rating Co (kN)	Static Rated Moment			Weight										
	H	H1	N	W	B	B1	C	L1	L	K1	K2	G	M	T	T1	H2	H3				WR	HR	D	h	d	P	E	C (kN)	Co (kN)	MR	MP	MY	Block	Rail
																														kN-m	kN-m	kN-m	kg	kg/m
EGW15SB	24	4.5	18.5	52	41	5.5	-	23.1	40.1	14.8	3.5	5.7	Ø4.5	5	7	5.5	6	15	12.5	6	4.5	3.5	60	20	M3x16	5.35	9.40	0.08	0.04	0.04	0.12	1.25		
EGW15CB							26	39.8	56.8	10.15																								
EGW20SB	28	6	19.5	59	49	5	-	29	50	18.75	4.15	12	Ø5.5	7	9	6	6	20	15.5	9.5	8.5	6	60	20	M5x16	7.23	12.74	0.13	0.06	0.06	0.19	2.08		
EGW20CB							32	48.1	69.1	12.3																								
EGW25SB	33	7	25	73	60	6.5	-	35.5	59.1	21.9	4.55	12	Ø7	7.5	10	8	8	23	18	11	9	7	60	20	M6x20	11.40	19.50	0.23	0.12	0.12	0.35	2.67		
EGW25CB							35	59	82.6	16.15																								
EGW30SB	42	10	31	90	72	9	-	41.5	69.5	26.75	6	12	Ø9	7	10	8	9	28	23	11	9	7	80	20	M6x25	16.42	28.10	0.40	0.21	0.21	0.62	4.35		
EGW30CB							40	70.1	98.1	21.05																								
EGW35SB	48	11	33	100	82	9	-	45	75	28.5	7	12	Ø9	10	13	8.5	8.5	34	27.5	14	12	9	80	20	M8x25	22.66	37.38	0.56	0.31	0.31	0.84	6.14		
EGW35CB							50	78	108	20																								

Note : 1 kgf = 9.81 N



(4) Dimensions for EGR-U (large mounting hole, rail mounting from top)

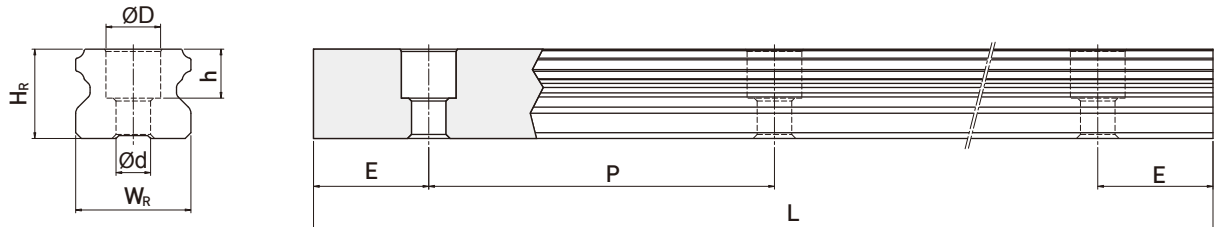

Model No.	Mounting Bolt for Rail(mm)	Dimensions of Rail (mm)							Weight (kg/m)
		$\text{W}_R$	$\text{H}_R$	$\text{D}$	$\text{h}$	$\text{d}$	$\text{P}$	$\text{E}$	
EGR15U	M4x16	15	12.5	7.5	5.3	4.5	60	20	1.23
EGR30U	M8x25	28	23	14	12	9	80	20	4.23

(5) Dimensions for EGR-T (rail mounting from bottom)

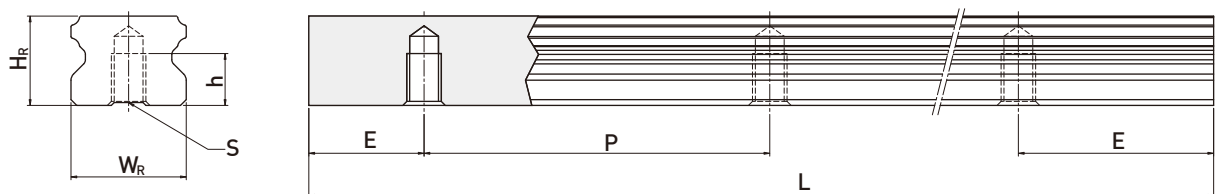

Model No.	Dimensions of Rail (mm)						Weight (kg/m)
	$\text{W}_R$	$\text{H}_R$	$\text{S}$	$\text{h}$	$\text{P}$	$\text{E}$	
EGR15T	15	12.5	M5 x 0.8P	7	60	20	1.26
EGR20T	20	15.5	M6 x 1P	9	60	20	2.15
EGR25T	23	18	M6 x 1P	10	60	20	2.79
EGR30T	28	23	M8 x 1.25P	14	80	20	4.42
EGR35T	34	27.5	M8 x 1.25P	17	80	20	6.34