

## 2-8 CG Series - Superior Rolling Moment with Cover Strip Linear Guideway

CG series linear guideways are a four-row arc-tooth contact type, featuring high rigidity, high load, and high torsional resistance. It also has four-way load characteristics. This specification can be matched with the latest slide dustproof accessories.

### 2-8-1 Features of CG Series

#### (1) High rolling moment resistance

CG rail designed with DB type (also known as o arrangement) has longer range of moment compared to DF type (also known as x arrangement). It is suitable for applications that have larger rolling moment.

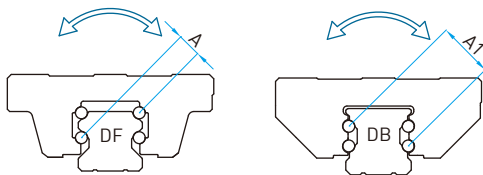

#### Rigidity Test

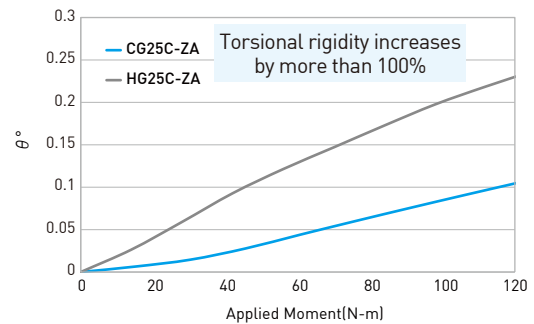

#### (2) Optimal recirculation path

Better smoothness due to integrated component.

#### (3) Better protection

The CG series uses a metal scraper as a standard accessory for protection against high temperature chips and particles.

#### (4) Latest dustproof accessory for rail

The CG series offers a special stainless cover strip for better dust protection than standard bolt caps.

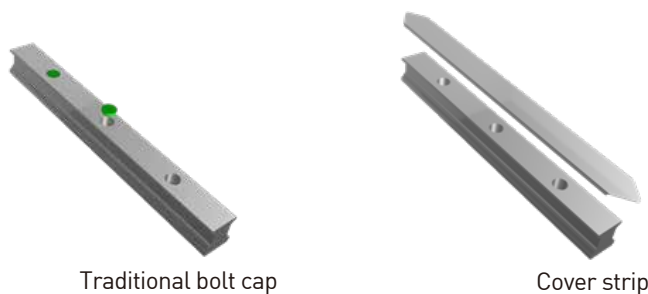

#### (5) Full lubrication

Specially designed for short stroke motion.

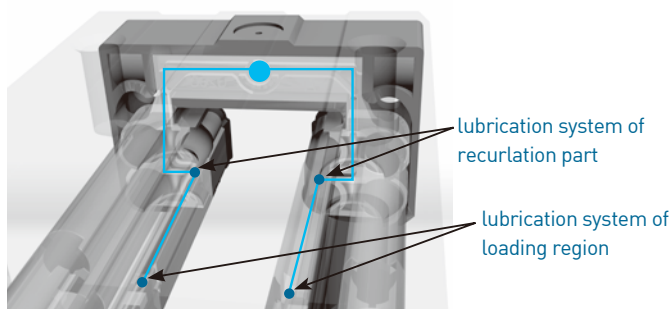

## CG Series

### Superior Rolling Moment with Cover Strip

#### 2-8-2 Construction of CG Series

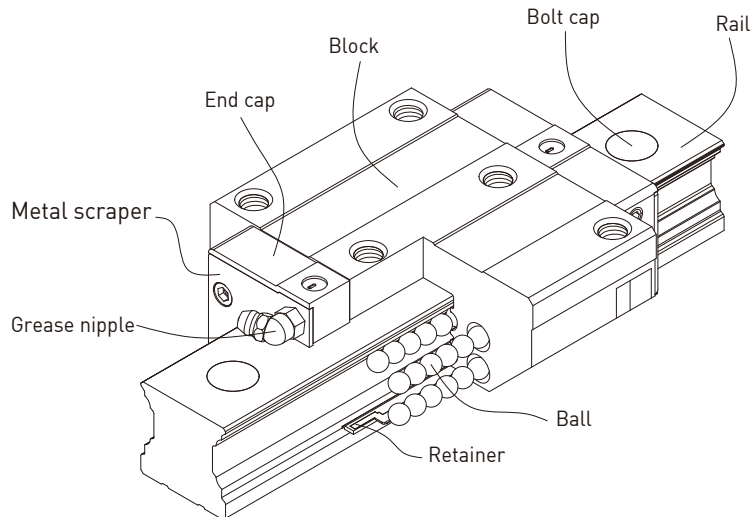

- Rolling circulation system: Block, Rail, End Cap and Retainer
- Lubrication system: Grease Nipple and Piping Joint
- Dust protection system: End seal, Bottom Seal, Bolt Cap, Metal scraper

#### 2-8-3 Model Number of CG Series

CG series guideways can be classified into non-interchangeable and interchangeable types. The sizes are identical. The only difference between the two types is that the interchangeable type of blocks and rails can be freely exchanged, and their accuracy can reach up to P class. The model number of CG series contains the size, type, accuracy class, preload class, etc..

(1) Non-interchangeable type

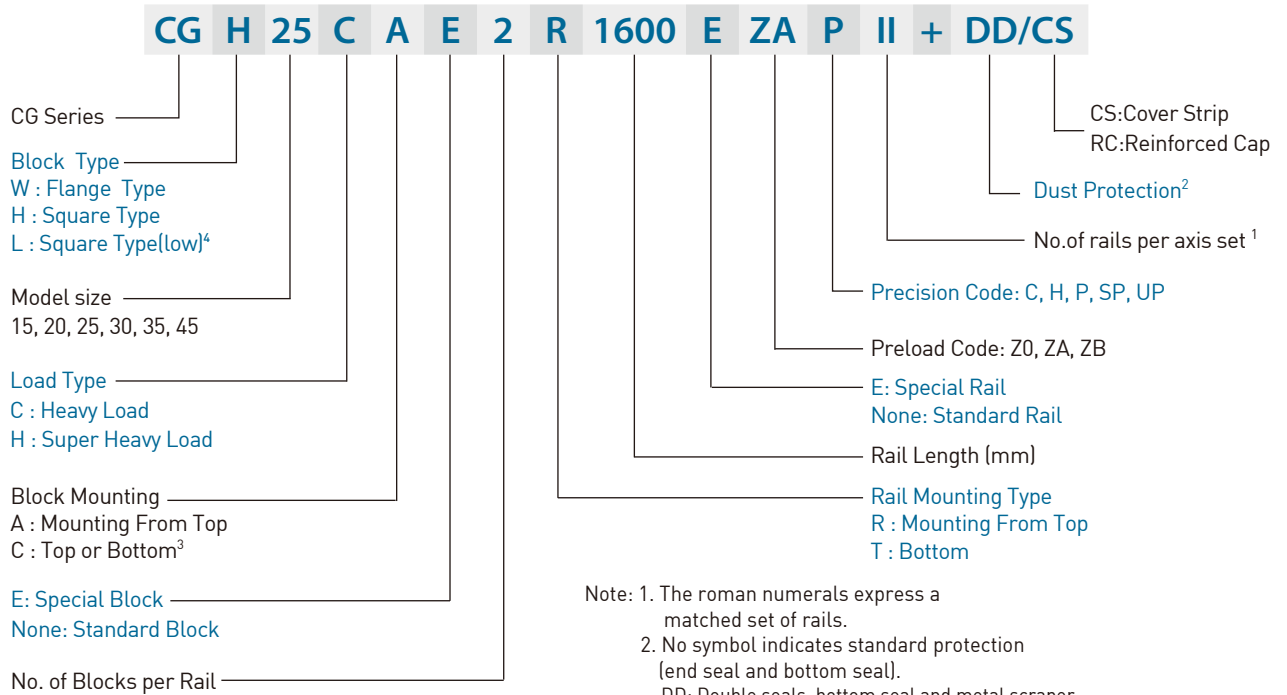

- Note: 1. The roman numerals express a matched set of rails.  
 2. No symbol indicates standard protection (end seal and bottom seal).  
 DD: Double seals, bottom seal and metal scraper  
 3. For mounting type A ,The amount of block mounting holes is four. For mounting type C ,The amount of block mounting holes is six. Both types can be mounting from top or bottom.  
 4. Block type CGL is the low profile design of CGH (square type), the assembled height is same as CGW (flange type) in same size.

(2) Interchangeable type

○ Model Number of CG Block

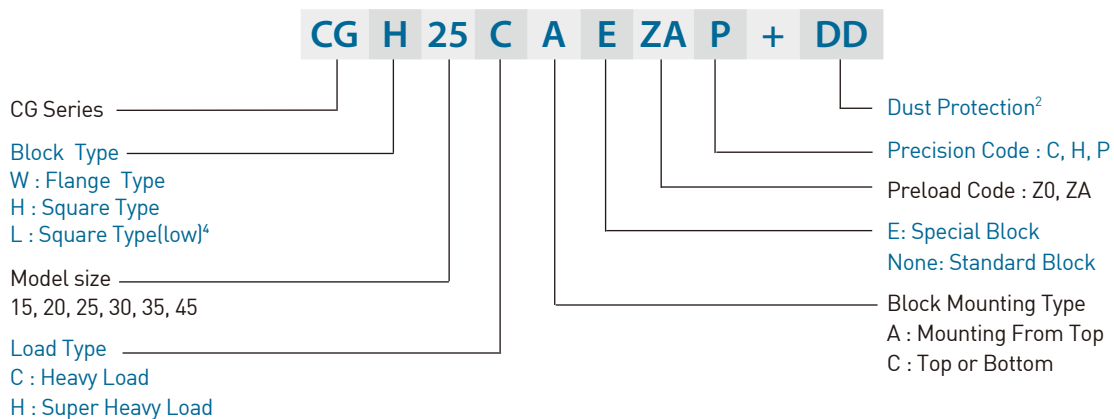

○ Model Number of CG Rail

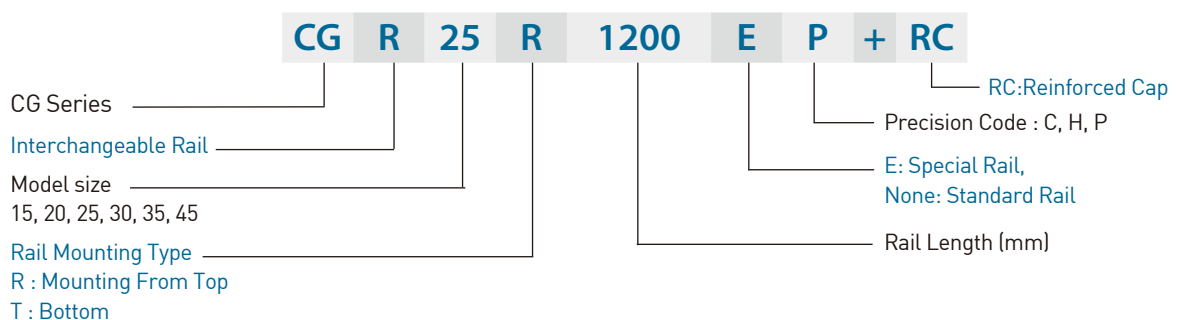

## CG Series

### Superior Rolling Moment with Cover Strip

#### 2-8-4 Types

##### (1) Block types

There are two types of blocks: flange and square.

Table 2-8-1 Block Types

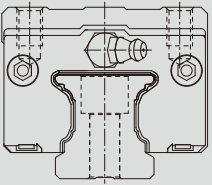
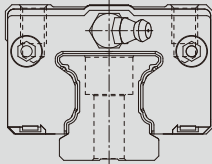
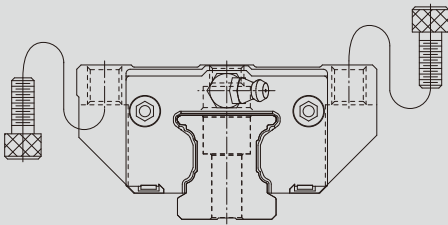
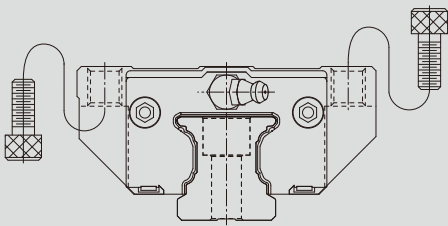
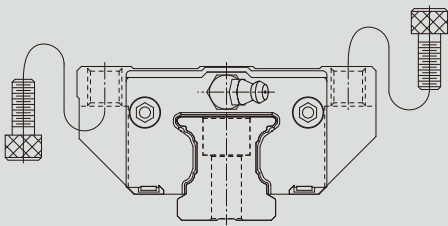
Type	Model	Shape	Height (mm)	Rail Length (mm)	Main Application
Square	CGH-CA CGH-HA		28	100	<ul style="list-style-type: none"> <li>○ Machine Centers</li> <li>○ NC Lathes</li> <li>○ Grinding Machines</li> <li>○ Precision Machining Machines</li> <li>○ Heavy Cutting Machines</li> <li>○ Automation Devices</li> <li>○ Transportation Equipment</li> <li>○ Measuring Equipment</li> <li>○ Devices Requiring High Positional Accuracy</li> </ul>
			↓	↓	
Square	CGL-CA CGL-HA		24	100	
			↓	↓	
Flange	CGW-CC CGW-HC		60	4000	
			↓	↓	
Flange	CGW-CA CGW-HA		24	100	
			↓	↓	
Flange	CGW-CA CGW-HA		60	4000	
			↓	↓	

##### (2) Rail types

Besides the standard top mounting type, the bottom mounting type is also available.

Table 2-8-2 Rail Types

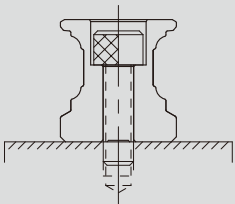
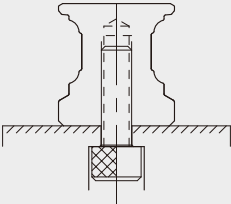
Mounting from Top	Mounting from bottom
	

## 2-8-5 Accuracy Classes

The accuracy of CG series can be classified into five classes: normal (C), high (H), precision (P), super precision (SP), ultra precision (UP). Please choose the class by referring the accuracy of applied equipment.

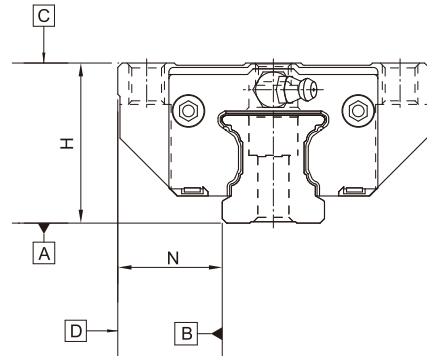

### (1) Accuracy of non-interchangeable guideways

Table 2-8-3 Accuracy Standards

Unit: mm

Item	CG - 15, 20				
	Normal (C)	High (H)	Precision (P)	Super Precision (SP)	Ultra Precision (UP)
Dimensional tolerance of height H	± 0.1	± 0.03	0 - 0.03	0 - 0.015	0 - 0.008
Dimensional tolerance of width N	± 0.1	± 0.03	0 - 0.03	0 - 0.015	0 - 0.008
Variation of height H	0.02	0.01	0.006	0.004	0.003
Variation of width N	0.02	0.01	0.006	0.004	0.003
Running parallelism of block surface C to surface A	See Table 2-8-9				
Running parallelism of block surface D to surface B	See Table 2-8-9				

Table 2-8-4 Accuracy Standards

Unit: mm

Item	CG - 25, 30, 35				
	Normal (C)	High (H)	Precision (P)	Super Precision (SP)	Ultra Precision (UP)
Dimensional tolerance of height H	± 0.1	± 0.04	0 - 0.04	0 - 0.02	0 - 0.01
Dimensional tolerance of width N	± 0.1	± 0.04	0 - 0.04	0 - 0.02	0 - 0.01
Variation of height H	0.02	0.015	0.007	0.005	0.003
Variation of width N	0.03	0.015	0.007	0.005	0.003
Running parallelism of block surface C to surface A	See Table 2-8-9				
Running parallelism of block surface D to surface B	See Table 2-8-9				

Table 2-8-5 Accuracy Standards

Unit: mm

Item	CG - 45				
	Normal (C)	High (H)	Precision (P)	Super Precision (SP)	Ultra Precision (UP)
Dimensional tolerance of height H	± 0.1	± 0.05	0 - 0.05	0 - 0.03	0 - 0.02
Dimensional tolerance of width N	± 0.1	± 0.05	0 - 0.05	0 - 0.03	0 - 0.02
Variation of height H	0.03	0.015	0.007	0.005	0.003
Variation of width N	0.03	0.02	0.01	0.007	0.005
Running parallelism of block surface C to surface A	See Table 2-8-9				
Running parallelism of block surface D to surface B	See Table 2-8-9				

## CG Series

### Superior Rolling Moment with Cover Strip

#### (2) Accuracy of interchangeable guideways

Table 2-8-6 Accuracy Standards

Unit: mm

Item	CG - 15, 20		
Accuracy Classes	Normal (C)	High (H)	Precision (P)
Dimensional tolerance of height H	± 0.1	± 0.03	± 0.015
Dimensional tolerance of width N	± 0.1	± 0.03	± 0.015
Variation of height H	0.02	0.01	0.006
Variation of width N	0.02	0.01	0.006
Running parallelism of block surface C to surface A	See Table 2-8-9		
Running parallelism of block surface D to surface B	See Table 2-8-9		

Table 2-8-7 Accuracy Standards

Unit: mm

Item	CG - 25, 30, 35		
Accuracy Classes	Normal (C)	High (H)	Precision (P)
Dimensional tolerance of height H	± 0.1	± 0.04	± 0.02
Dimensional tolerance of width N	± 0.1	± 0.04	± 0.02
Variation of height H	0.02	0.015	0.007
Variation of width N	0.03	0.015	0.007
Running parallelism of block surface C to surface A	See Table 2-8-9		
Running parallelism of block surface D to surface B	See Table 2-8-9		

Table 2-8-8 Accuracy Standards

Unit: mm

Item	CG - 45		
Accuracy Classes	Normal (C)	High (H)	Precision (P)
Dimensional tolerance of height H	± 0.1	± 0.05	± 0.025
Dimensional tolerance of width N	± 0.1	± 0.05	± 0.025
Variation of height H	0.03	0.015	0.007
Variation of width N	0.03	0.02	0.01
Running parallelism of block surface C to surface A	See Table 2-8-9		
Running parallelism of block surface D to surface B	See Table 2-8-9		

### (3) Accuracy of running parallelism

Table 2-8-9 Accuracy of Running Parallelism

Rail Length (mm)	Accuracy (μm)					
	C	H	P	SP	H	UP
~ 100	12	7	3	2		2
100 ~ 200	14	9	4	2		2
200 ~ 300	15	10	5	3		2
300 ~ 500	17	12	6	3		2
500 ~ 700	20	13	7	4		2
700 ~ 900	22	15	8	5		3
900 ~ 1,100	24	16	9	6		3
1,100 ~ 1,500	26	18	11	7		4
1,500 ~ 1,900	28	20	13	8		4
1,900 ~ 2,500	31	22	15	10		5
2,500 ~ 3,100	33	25	18	11		6
3,100 ~ 3,600	36	27	20	14		7
3,600 ~ 4,000	37	28	21	15		7

## 2-8-6 Preload

### (1) Definition

A preload can be applied to each guideway. Oversized balls are used. Generally, a linear motion guideway has a negative clearance between groove and balls in order to improve stiffness and maintain high precision. The figure shows the load is multiplied by the preload, the rigidity is doubled and the deflection is reduced by one half. The preload no larger than ZA would be recommended for the model size under HG20 to avoid an over-preload affecting the guideway's life.

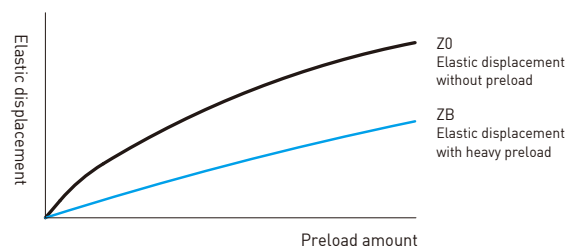

### (2) Preload classes

HIWIN offers three classes of standard preload for various applications and conditions.

Table 2-8-10 Preload Classes

Class	Code	Preload	Condition	Examples of Application
Light Preload	Z0	0~ 0.02C	Certain load direction, low impact, low precision required	Transportation devices, auto-packing machines, X-Y axis for general industrial machines, welding machines, welders
Medium Preload	ZA	0.05C~0.07C	High precision required	Machining centers, Z axis for general industrial machines, EDM, NC lathes, Precision X-Y tables, measuring equipment
Heavy Preload	ZB	0.10C~ 0.12C	High rigidity required, with vibration and impact	Machining centers, grinding machines, NC lathes, horizontal and vertical milling machines, Z axis of machine tools, Heavy cutting machines
<b>Class</b>	<b>Interchangeable Guideway</b>			<b>Non-Interchangeable Guideway</b>
Preload classes	Z0, ZA			Z0, ZA, ZB

Note: The "C" in the preload column denotes basic dynamic load rating.

## CG Series

### Superior Rolling Moment with Cover Strip

#### (3) Stiffness performance

Stiffness depends on preload. The following table shows stiffness value of each size.

Table 2-8-11 Radial stiffness for CG Series

Load type	Series / Size	Stiffness (N/ $\mu$ m)		
		Z0	ZA	ZB
Heavy load	CG 15C	180	341	482
	CG 20C	258	540	701
	CG 25C	290	581	786
	CG 30C	342	595	907
	CG 35C	378	606	950
	CG 45C	443	634	999
Super heavy load	CG 20H	331	716	918
	CG 25H	351	720	969
	CG 30H	449	802	1208
	CG 35H	497	813	1269
	CG 45H	587	842	1291

## 2-8-7 Lubrication

### (1) Grease

#### ○ Grease nipple

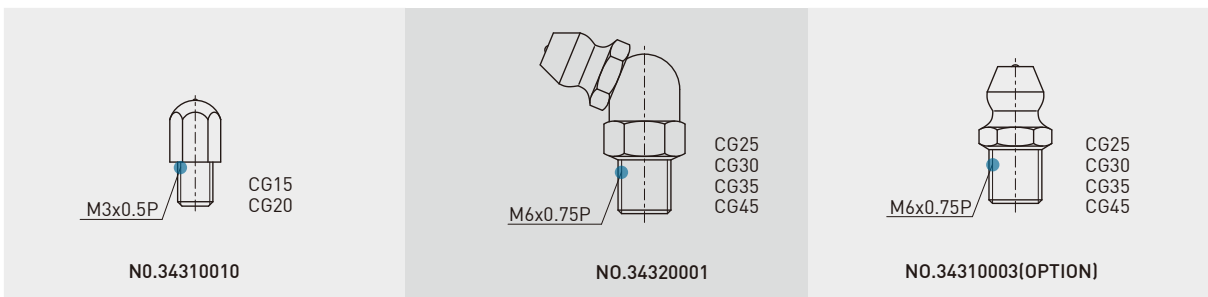

#### ○ Mounting location

The standard location of the grease fitting is at both ends of the block, but the nipple can be mounted at each side of block. For lateral installation, we recommend that the nipple can be mounted at the non-reference side, otherwise please contact us. It is possible to perform lubrication by using the oil-piping joint.

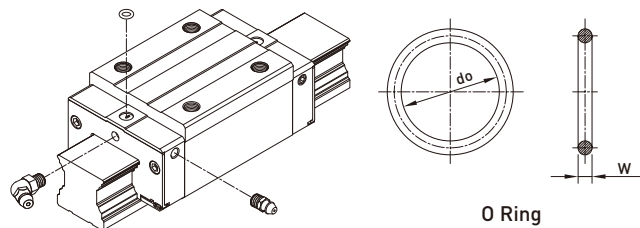
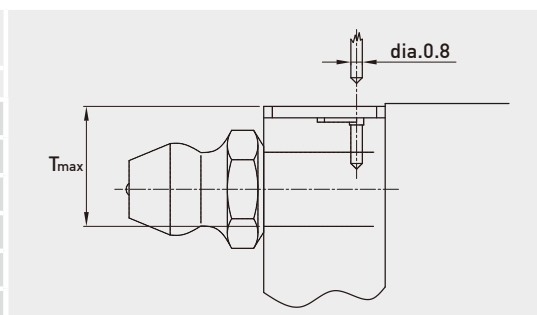

Table 2-8-12 O-Ring size and max. permissible depth for piercing

Size	O-Ring		Lube hole at top: max. permissible depth for piercing
	do (mm)	W (mm)	T <sub>max</sub> (mm)
CG15	2.5±0.15	1.5±0.15	3.75
CG20	4.5±0.15	1.5±0.15	5.7
CG25	4.5±0.15	1.5±0.15	5.8
CG30	4.5±0.15	1.5±0.15	6.3
CG35	4.5±0.15	1.5±0.15	8.8
CG45	4.5±0.15	1.5±0.15	8.2





○ The lubricant amount for a block filled with grease

Table 2-8-13 The lubricant Amount for a Block Filled with Grease

Size	Heavy load (cm <sup>3</sup> )	Super Heavy load (cm <sup>3</sup> )	Size	Heavy load (cm <sup>3</sup> )	Super Heavy load (cm <sup>3</sup> )
CG15	1	-	CG30	3.5	5
CG20	2	3	CG35	7	9
CG25	2.5	4	CG45	8.5	-

Note : If other size is needed, please contact HIWIN.

○ Frequency of replenishment

Table 2-8-14 Frequency of replenishment for one block

Recommended lubrication interval [km]					
Size	P/C < 0,1	0,1 < P/C < 0,3	Size	P/C < 0,1	0,1 < P/C < 0,3
CG15	3000	(C/P)*100	CG30	3000	(C/P)*100
CG20	3000	(C/P)*100	CG35	3000	(C/P)*100
CG25	3000	(C/P)*100	CG45	3000	(C/P)*100

C : Dynamic rating P : Loading

(2) Oil

The recommended viscosity of oil is about 30~150cSt. If customers need to use oil-type lubrication, please inform us.

○ Types of oil piping joint

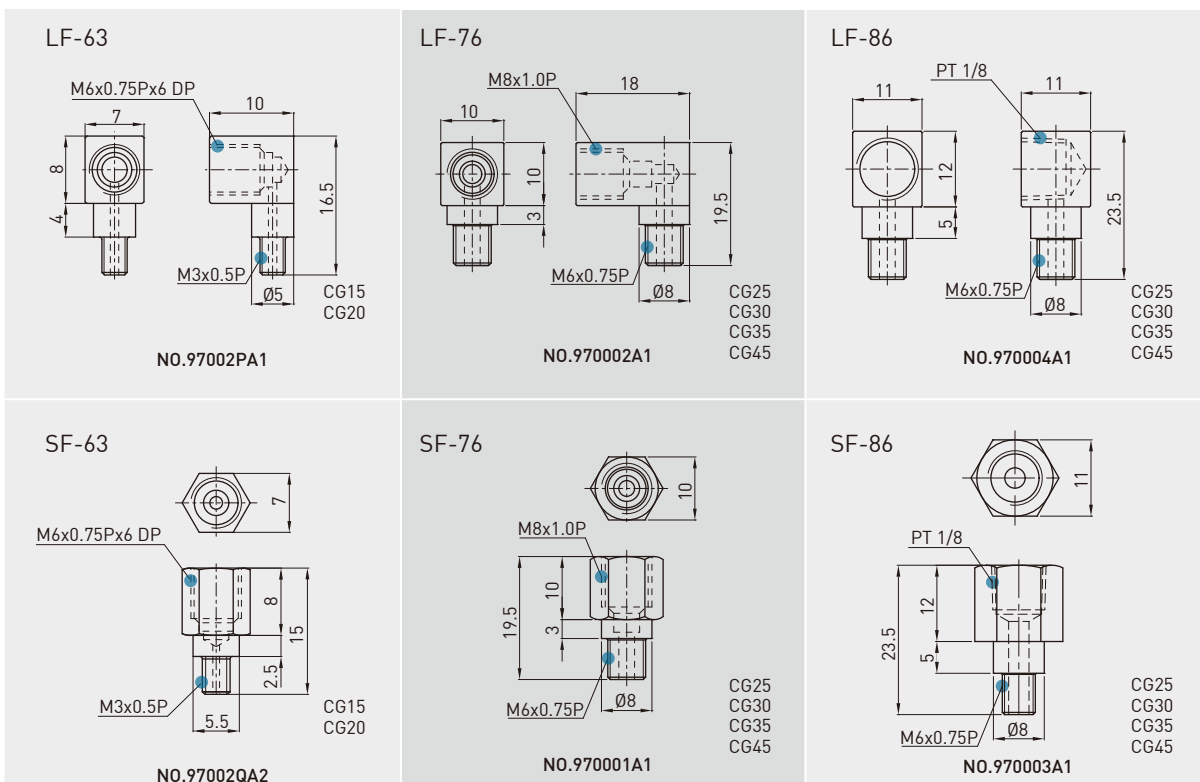

○ Oil refilling rate

Table 2-8-15

Size	Refilling rate (cm <sup>3</sup> /hr)	Size	Refilling rate (cm <sup>3</sup> /hr)
CG 15	0.2	CG 30	0.3
CG 20	0.2	CG 35	0.3
CG 25	0.3	CG 45	0.4

## CG Series

### Superior Rolling Moment with Cover Strip

#### 2-8-8 Dust Proof Accessories

##### (1) Codes of standard dust proof accessories

If the following accessories are needed, please add the code followed by the model number.

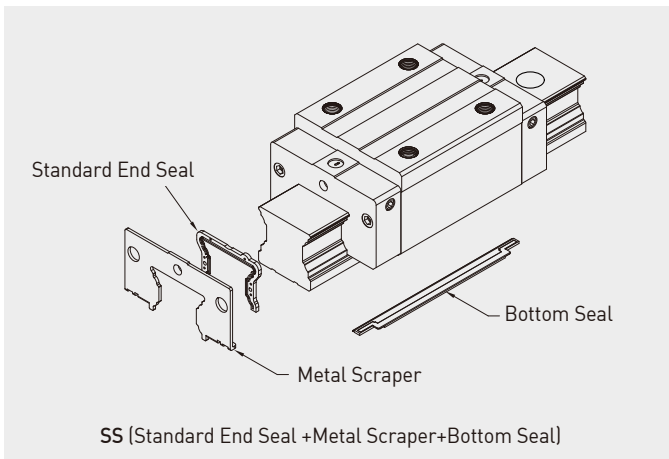

##### (2) Codes of high-dust proof accessories

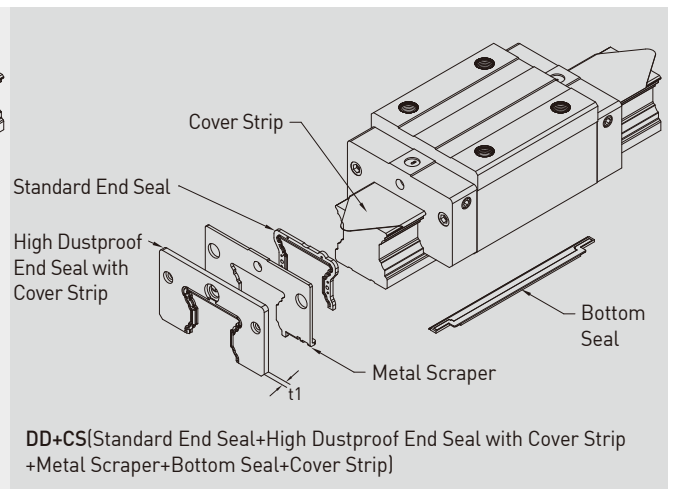
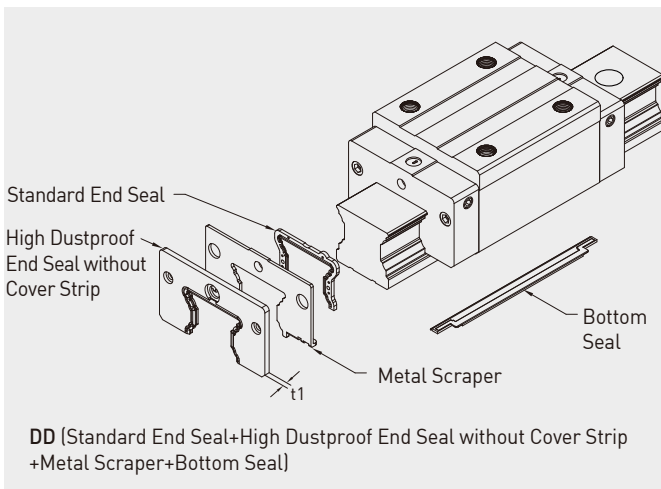

##### (3) Function of dust proof accessories

###### ○ End seal and bottom seal

To prevent life reduction caused by iron chips or dust entering the block.

###### ○ Double seals

Enhances the wiping effect, foreign matter can be completely wiped off.

Table 2-8-16 Dimensions of end seal

Size	Thickness (t1) (mm)	Size	Thickness (t1) (mm)
CG15	2.8	CG30	2.8
CG20	2.8	CG35	2.8
CG25	2.5	CG45	2.7

○ Cover Strip

The cover strip offers better dust proof protection than rail bolt caps and is easier to install. The strip is held in place by a plastic retainer at each end. For high temperature environments a metal retainer is available.

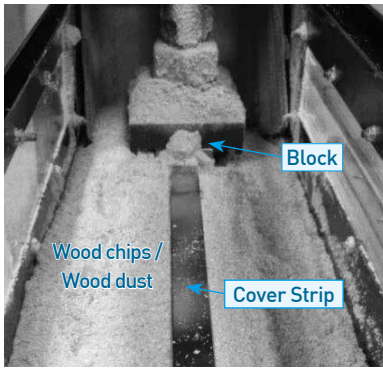

Spec.	CGH25CA1R700Z0C+DD/CS	 <p><b>Test result</b> No dust get into ball tracks</p>
Max.velocity/ acceleration	1m/s,1G	
Loading	Fixture weight	
Distance	1500km	
Dust type	Wood chips / Wood dust	
Diameter	100~500µm	

○ Bolt caps for rail mounting holes

Caps are used to cover the mounting holes to prevent chips or other foreign objects from collecting in the holes. The caps will be enclosed in each rail package.

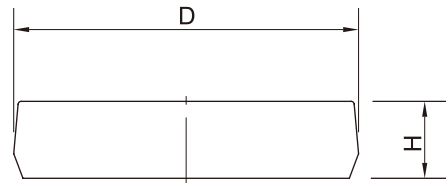

Table 2-8-17 Dimensions of Bolt Caps for Rail Mounting Holes

Rail size	Bolt size	Diameter(D) (mm)	Thickness(H) (mm)	Rail size	Bolt size	Diameter(D) (mm)	Thickness(H) (mm)
CGR15	M4	7.65	1.1	CGR30	M8	14.20	3.5
CGR20	M5	9.65	2.5	CGR35	M8	14.20	3.5
CGR25	M6	11.15	2.5	CGR45	M12	20.25	4.5

(4) Dimensions of block equipped with the parts

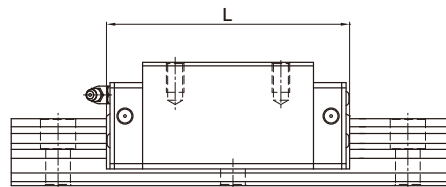

Table 2-8-18 Overall block length

unit: mm

Size	Overall block length (L)			Size	Overall block length (L)		
	SS	DD	DD+CS		SS	DD	DD+CS
CG15C	58.2	63.8	63.8	-	-	-	-
CG20C	74.9	80.5	80.5	CG20H	90.9	96.5	96.5
CG25C	84	89	89	CG25H	101.4	106.4	106.4
CG30C	97.4	103.8	103	CG30H	119.9	126.3	125.5
CG35C	111.4	117.8	117	CG35H	135.8	142.2	141.4
CG45C	137.6	145.6	145.6	CG45H	174	182	182

## CG Series

### Superior Rolling Moment with Cover Strip

#### 2-8-9 Friction

The maximum value of resistance per end seal are as shown in the table.

Table 2-8-19 Seal Resistance

Size	Resistance N (kgf)	Size	Resistance N (kgf)
CG15	0.98 (0.1)	CG30	3.43 (0.35)
CG20	1.96 (0.2)	CG35	3.92 (0.4)
CG25	3.43 (0.35)	CG45	4.9 (0.5)

Note : 1 kgf = 9.81N

Other specifications please contact HIWIN

#### 2-8-10 The Accuracy Tolerance of Mounting Surface

CG rail designed with DB type (also known as o arrangement) which has better moment load capacity. Moreover, The CG series can compensate for some surface-error on installation and still maintain smooth linear motion due to circular-arc contact design.

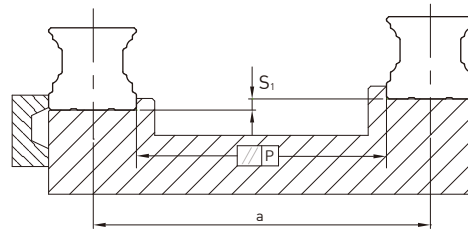

Table 2-8-20 Max. Parallelism Tolerance (P)

unit: μm

Size	Preload classes		
	Z0	ZA	ZB
CG15	9	5	4
CG20	11	7	5
CG25	12	8	6
CG30	14	9	7
CG35	15	11	8
CG45	19	12	10

- The accuracy tolerance of reference surface height (S<sub>1</sub>)

$$S_1 = K \cdot 10^{[-4]} \cdot a - T_H$$

S<sub>1</sub> : Max. tolerance of height

a : Distance between paired rails

K : Coefficient of tolerance of height

T<sub>H</sub> : dimensional tolerance of height, please refer to accuracy class

Table 2-8-21 Coefficient of tolerance of height

Size	Preload classes		
	Light Preload (Z0)	Medium Preload (ZA)	Heavy Preload (ZB)
K [μm/mm]	2.8	1.7	1.2

## 2-8-11 Cautions for Installation

### (1) Shoulder heights and fillets

Improper shoulder heights and fillets of mounting surfaces will cause a deviation in accuracy and the interference with the chamfered part of the rail or block. As long as the recommended shoulder heights and fillets are followed, installation inaccuracies should be eliminated.

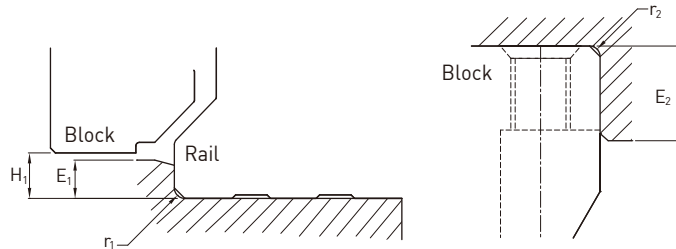

Table 2-8-22 Shoulder Heights and Fillets

Size	Max. radius of fillets $r_1$ (mm)	Max. radius of fillets $r_2$ (mm)	Shoulder height of the rail $E_1$ (mm)	Shoulder height of the block $E_2$ (mm)	Clearance under block $H_1$ (mm)
CG 15	0.5	0.5	3.0	4.0	4.3
CG 20	0.5	0.5	3.5	5.0	4.6
CG 25	1.0	1.0	5.0	5.0	5.5
CG 30	1.0	1.0	5.0	5.0	6.0
CG 35	1.0	1.0	6.0	6.0	7.5
CG 45	1.0	1.0	8.0	8.0	9.5

### (2) Tightening Torque of Bolts for Installation

Improper tightening of bolts will seriously influence the accuracy of Linear Guideway installation. The following tightening torques for different sizes of bolts are recommended.

Table 2-8-23 Mounting Torque

Size	Bolt size	Torque N-cm (kgf-cm)		
		Iron	Casting	Aluminum
CG 15	M4×0.7P×16L	392(40)	274(28)	206(21)
CG 20	M5×0.8P×16L	883(90)	588(60)	441(45)
CG 25	M6×1P×20L	1373(140)	921(94)	686(70)
CG 30	M8×1.25P×25L	3041(310)	2010(205)	1470(150)
CG 35	M8×1.25P×25L	3041(310)	2010(205)	1470(150)
CG 45	M12×1.75P×35L	11772(1200)	7840(800)	5880(600)

Note : 1 kgf = 9.81N

## CG Series

### Superior Rolling Moment with Cover Strip

#### 2-8-12 Standard and Maximum Lengths of Rail

HIWIN offers standard rail lengths for customer needs. For non-standard E-values, the recommended dimension should not be greater than 1/2 of the pitch (P) dimension. This will prevent an unstable rail end.

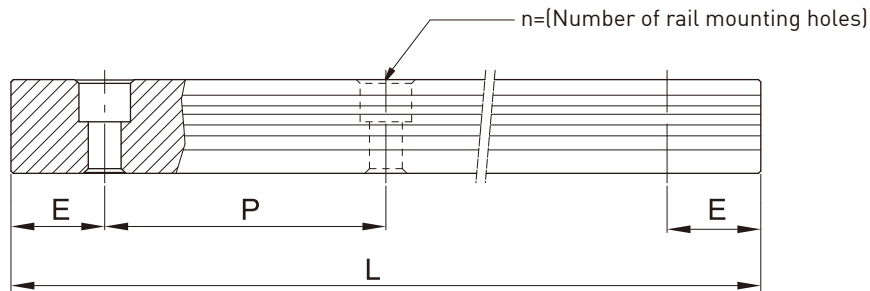

$$L = (n - 1) \times P + 2 \times E \quad \text{Eq.2.1}$$

L : Total length of rail (mm)

n : Number of mounting holes

P : Distance between any two holes (mm)

E : Distance from the center of the last hole to the edge (mm)

Table 2-8-24 Rail Standard Length and Max. Length

unit: mm

Item	CG15	CG20	CG25	CG30	CG35	CG45
Standard Length L(n)	160(3)	220(4)	220(4)	280(4)	280(4)	570(6)
	220(4)	280(5)	280(5)	440(6)	440(6)	885(9)
	280(5)	340(6)	340(6)	600(8)	600(8)	1,200(12)
	340(6)	460(8)	460(8)	760(10)	760(10)	1,620(16)
	460(8)	640(11)	640(11)	1,000(13)	1,000(13)	2,040(20)
	640(11)	820(14)	820(14)	1,640(21)	1,640(21)	2,460(24)
	820(14)	1,000(17)	1,000(17)	2,040(26)	2,040(26)	2,985(29)
		1,240(21)	1,240(21)	2,520(32)	2,520(32)	
		1,600(27)	3,000(38)	3,000(38)		
Pitch (P)	60	60	60	80	80	105
Distance to End (E <sub>s</sub> )	20	20	20	20	20	22.5
Max. Standard Length	4,000(67)	4,000(67)	4,000(67)	3,960(50)	3,960(50)	3,930(38)
Max. Length	4,000	4,000	4,000	4,000	4,000	4,000

- Note :
1. Tolerance of E value for standard rail is 0.5~-0.5 mm. Tolerance of E value for jointed rail is 0~-0.3 mm.
  2. Maximum standard length means the max. rail length with standard E value on both sides.
  3. If different E value is needed, please contact HIWIN.

## 2-8-13 Dimensions for HIWIN CG Series

### (1) CGH-CA / CGH-HA

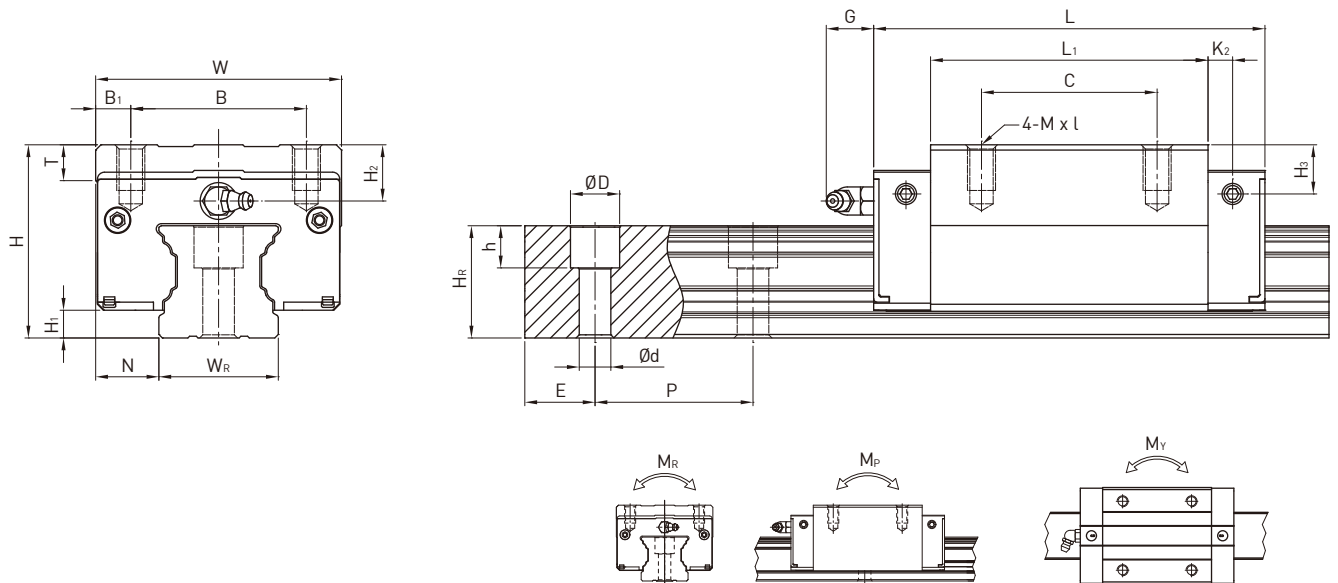

Model No.	Dimensions of Assembly (mm)			Dimensions of Block (mm)											Dimensions of Rail (mm)						Mounting Bolt for Rail (mm)	Basic Dynamic Load Rating C (kN)	Basic Static Load Rating C <sub>0</sub> (kN)	Static Rated Moment			Weight			
	H	H <sub>1</sub>	N	W	B	B <sub>1</sub>	C	L <sub>1</sub>	L	G	K <sub>2</sub>	T	H <sub>2</sub>	H <sub>3</sub>	M x l	W <sub>R</sub>	H <sub>R</sub>	D	h	d				P	E	M <sub>R</sub> kN-m	M <sub>p</sub> kN-m	M <sub>y</sub> kN-m	Block kg	Rail kg/m
CGH15CA	28	4.1	9.5	34	26	4	26	39.6	58.2	6	4.25	6	7.8	7.8	M4 x 6	15	16.2	7.5	5.9	4.5	60	20	M4x17	14.7	19.52	0.19	0.14	0.14	0.15	1.58
CGH20CA	30	4.65	12	44	32	6	36	52.5	74.9	6	5.5	8	3.7	3.5	M5 x 6	20	20.55	9.5	8.5	6	60	20	M5x19	23.7	30.51	0.37	0.28	0.28	0.25	2.48
CGH20HA	30	4.65	12	44	32	6	50	68.5	90.9	6	5.5	8	3.7	3.5	M5 x 6	20	20.55	9.5	8.5	6	60	20		28.6	39.9	0.48	0.48	0.48	0.33	2.48
CGH25CA	40	6.1	12.5	48	35	6.5	35	61	84	13	5	8	10	9.5	M6 x 8	23	24.25	11	9	7	60	20	M6x22	34.96	43.94	0.6	0.49	0.49	0.46	3.38
CGH25HA	40	6.1	12.5	48	35	6.5	50	78.4	101.4	13	5	8	10	9.5	M6 x 8	23	24.25	11	9	7	60	20		40.5	54.08	0.74	0.73	0.73	0.59	3.38
CGH30CA	45	7	16	60	40	10	40	69	97.4	13	8.7	9.5	9.7	10	M8 x 10	28	28.35	14	12	9	80	20	M8x25	46	55.19	0.95	0.7	0.7	0.71	5.1
CGH30HA	45	7	16	60	40	10	60	91.5	119.9	13	8.7	9.5	9.7	10	M8 x 10	28	28.35	14	12	9	80	20		58.59	78.18	1.35	1.23	1.23	0.94	5.1
CGH35CA	55	7.6	18	70	50	10	50	79	111.4	13	7	10.2	16	14	M8 x 13	34	31.85	14	12	9	80	20	M8x28	61.17	79.3	1.73	1.09	1.09	1.24	7.14
CGH35HA	55	7.6	18	70	50	10	72	103.4	135.8	13	7	10.2	16	14	M8 x 13	34	31.85	14	12	9	80	20		77.9	112.34	2.46	2.02	2.02	1.62	7.14
CGH45CA	70	9.7	20.5	86	60	13	60	97.2	137.6	13	8.7	16	18.5	18.2	M10 x 17	45	39.85	20	17	14	105	22.5	M12x37	98.43	112.66	3.56	2.35	2.35	2.38	11.51
CGH45HA	70	9.7	20.5	86	60	13	80	133.6	174	13	8.7	16	18.5	18.2	M10 x 17	45	39.85	20	17	14	105	22.5		125.58	159.6	5.05	4.45	4.45	3.01	11.51

Note : 1 kgf = 9.81 N

# CG Series

## Superior Rolling Moment with Cover Strip

### (2) CGL-CA / CGL-HA

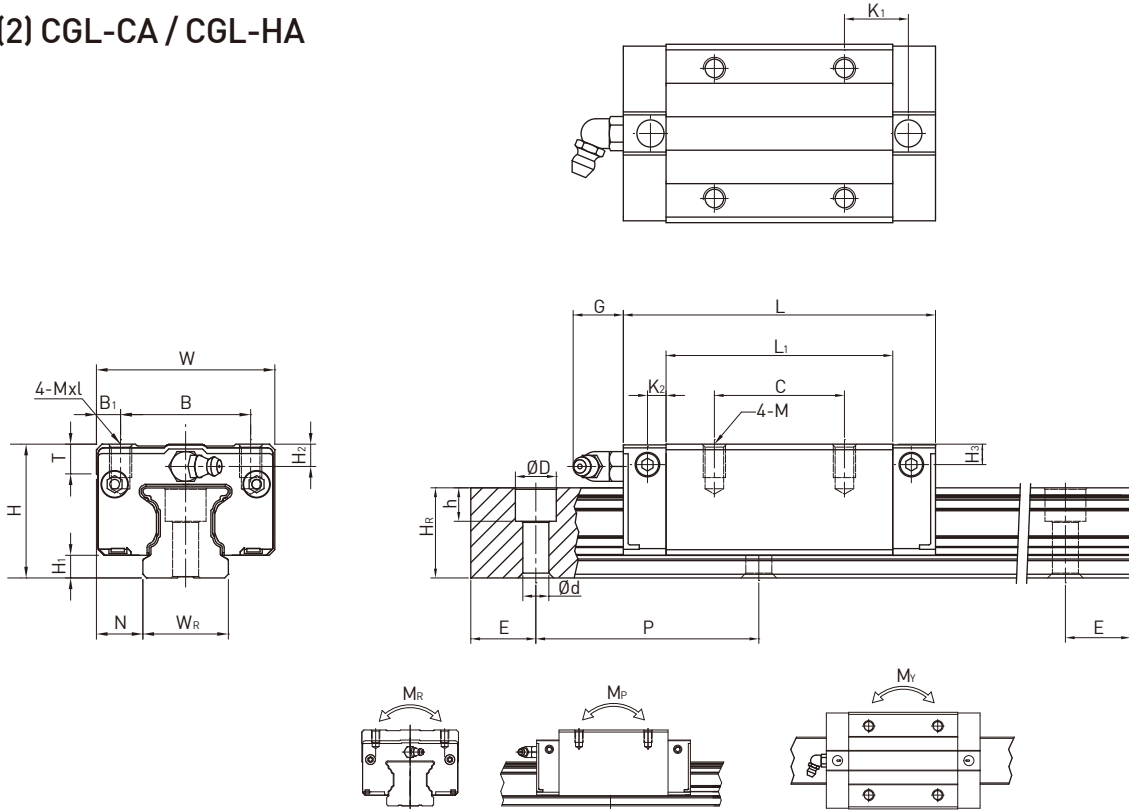

Model No.	Dimensions of Assembly (mm)			Dimensions of Block (mm)											Dimensions of Rail (mm)						Mounting Bolt for Rail (mm)	Basic Dynamic Load Rating C (kN)	Basic Static Load Rating Co (kN)	Static Rated Moment			Weight				
	H	H1	N	W	B	B1	C	L1	L	G	K1	K2	T	H2	H3	Mxl	WR	Hr	D	h				d	P	E	MR	MP	MY	Block kg	Rail kg/m
CGL15CA	24	4.1	9.5	34	26	4	26	39.6	58.2	6	6.8	4.3	6	3.8	3.8	M4x6	15	16.2	7.5	5.9	4.5	60	20	M4x17	14.7	19.52	0.19	0.14	0.14	0.11	1.58
CGL25CA	36	6.1	12.5	48	35	6.5	35	61	84	13	13	5	8	6	5.5	M6x8	23	24.25	11	9	7	60	20	M6x22	34.96	43.94	0.6	0.49	0.49	0.37	3.38
CGL25HA	36	6.1	12.5	48	35	6.5	50	78.4	101.4	13	14.2	5	8	6	5.5	M6x8	23	24.25	11	9	7	60	20		40.5	54.08	0.74	0.73	0.73	0.47	3.38
CGL30CA	42	7	16	60	40	10	40	69	97.4	13	14.5	8.7	9.5	6.7	7	M8x10	28	28	14	12	9	80	20	M8x25	46	55.19	0.95	0.7	0.7	0.61	5.1
CGL30HA	42	7	16	60	40	10	60	91.5	119.9	13	15.75	8.7	9.5	6.7	7	M8x10	28	28	14	12	9	80	20		58.59	78.18	1.35	1.23	1.23	0.82	5.1
CGL35CA	48	7.6	18	70	50	10	50	79	111.4	13	14.5	7	10.2	9	7	M8x13	34	31.85	14	12	9	80	20	M8x28	61.17	79.3	1.73	1.09	1.09	0.93	7.14
CGL35HA	48	7.6	18	70	50	10	72	103.4	135.8	13	15.7	7	10.2	9	7	M8x13	34	31.85	14	12	9	80	20		77.9	112.34	2.46	2.02	2.02	1.22	7.14
CGL45CA	60	9.7	20.5	86	60	13	60	97.2	137.6	13	18.6	8.7	16	8.5	8.2	M10x17	45	39.85	20	17	14	105	22.5	M12x37	98.43	112.66	3.56	2.35	2.35	1.72	11.51
CGL45HA	60	9.7	20.5	86	60	13	80	133.6	174	13	26.8	8.7	16	8.5	8.2	M10x17	45	39.85	20	17	14	105	22.5		125.58	159.6	5.05	4.45	4.45	2.39	11.51

Note : 1 kgf = 9.81 N



(3) CGW-CA / CGW-HA

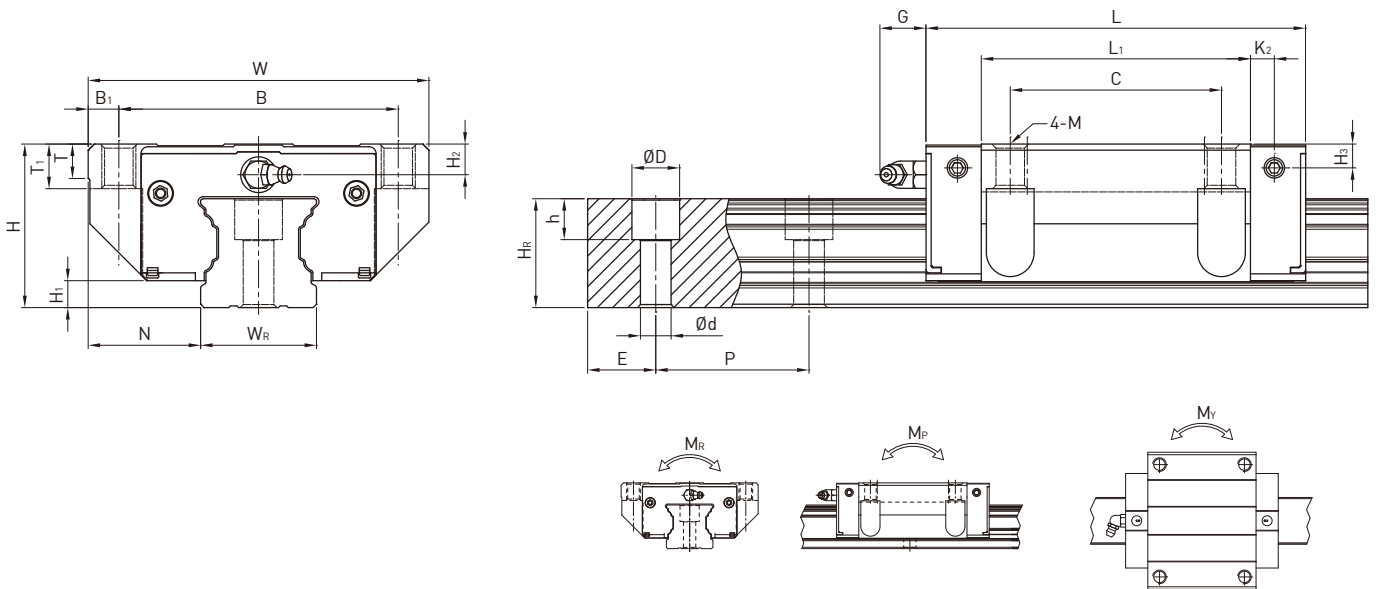

Model No.	Dimensions of Assembly (mm)			Dimensions of Block (mm)													Dimensions of Rail (mm)						Mounting Bolt for Rail (mm)	Basic Dynamic Load Rating C (kN)	Basic Static Load Rating C <sub>0</sub> (kN)	Static Rated Moment			Weight		
	H	H <sub>1</sub>	N	W	B	B <sub>1</sub>	C	L <sub>1</sub>	L	G	K <sub>2</sub>	T	T <sub>1</sub>	H <sub>2</sub>	H <sub>3</sub>	M	W <sub>R</sub>	H <sub>R</sub>	D	h	d	P				E	M <sub>R</sub> (kN-m)	M <sub>P</sub> (kN-m)	M <sub>Y</sub> (kN-m)	Block (kg)	Rail (kg/m)
	CGW15CA	24	4.1	16	47	38	4.5	30	39.6	58.2	6	4.25	5	6.5	3.8	3.8	M5	15	16.2	7.5	5.9	4.5				60	20	M4x17	14.7	19.52	0.19
CGW20CA	30	4.65	21.5	63	53	5	40	52.5	74.9	6	5.5	6.5	7.7	3.7	3.5	M6	20	20.55	9.5	8.5	6	60	20	M5x19	23.7	30.51	0.37	0.28	0.28	0.36	2.48
CGW20HA	30	4.65	21.5	63	53	5	40	68.5	90.9	6	5.5	6.5	7.7	3.7	3.5	M6	20	20.55	9.5	8.5	6	60	20		28.6	39.9	0.48	0.48	0.48	0.47	2.48
CGW25CA	36	6.1	23.5	70	57	6.5	45	61	84	13	5	7	9.3	6	5.5	M8	23	24.25	11	9	7	60	20	M6x22	34.96	43.94	0.6	0.49	0.49	0.53	3.38
CGW25HA	36	6.1	23.5	70	57	6.5	45	78.4	101.4	13	5	7	9.3	6	5.5	M8	23	24.25	11	9	7	60	20		40.5	54.08	0.74	0.73	0.73	0.68	3.38
CGW30CA	42	7	31	90	72	9	52	69	97.4	13	8.7	10.5	12	6.7	7	M10	28	28.35	14	12	9	80	20	M8x25	46	55.19	0.95	0.7	0.7	0.9	5.1
CGW30HA	42	7	31	90	72	9	52	91.5	119.9	13	8.7	10.5	12	6.7	7	M10	28	28.35	14	12	9	80	20		58.59	78.18	1.35	1.23	1.23	1.19	5.1
CGW35CA	48	7.6	33	100	82	9	62	79	111.4	13	7	10.1	13.1	9	7	M10	34	31.85	14	12	9	80	20	M8x28	61.17	79.3	1.73	1.09	1.09	1.37	7.14
CGW35HA	48	7.6	33	100	82	9	62	103.4	135.8	13	7	10.1	13.1	9	7	M10	34	31.85	14	12	9	80	20		77.9	112.34	2.46	2.02	2.02	1.79	7.14
CGW45CA	60	9.7	37.5	120	100	10	80	97.2	137.6	13	8.7	13.5	15	8.5	8.1	M12	45	39.85	20	17	14	105	22.5	M12x37	98.43	112.66	3.56	2.35	2.35	2.45	11.51
CGW45HA	60	9.7	37.5	120	100	10	80	133.6	174	13	8.7	13.5	15	8.5	8.1	M12	45	39.85	20	17	14	105	22.5		125.58	159.6	5.05	4.45	4.45	3	11.51

Note : 1 kgf = 9.81 N

# CG Series

Superior Rolling Moment with Cover Strip

## (4) CGW-CC / CGW-HC

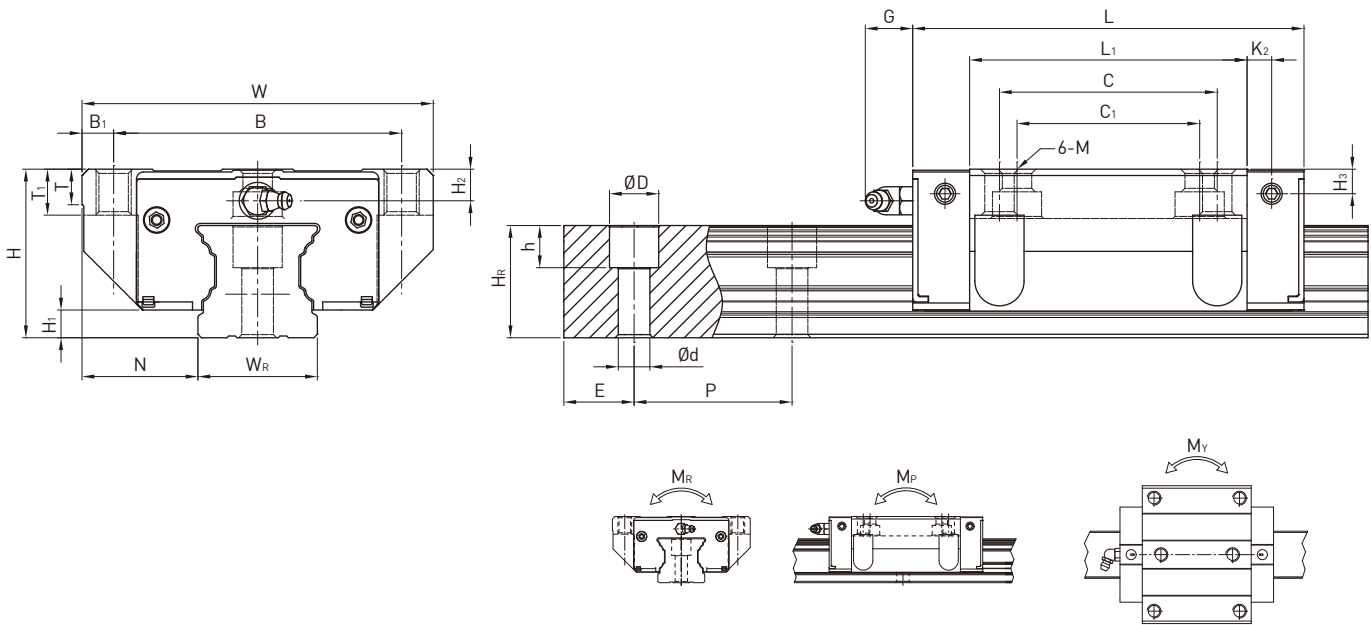

Model No.	Dimensions of Assembly (mm)			Dimensions of Block (mm)													Dimensions of Rail (mm)						Mounting Bolt for Rail (mm)	Basic Dynamic Load Rating C (kN)	Basic Static Load Rating C <sub>0</sub> (kN)	Static Rated Moment			Weight			
	H	H <sub>1</sub>	N	W	B	B <sub>1</sub>	C	C <sub>1</sub>	L <sub>1</sub>	L	G	K <sub>2</sub>	T	T <sub>1</sub>	H <sub>2</sub>	H <sub>3</sub>	M	W <sub>R</sub>	H <sub>R</sub>	D	h	d				P	E	M <sub>R</sub>	M <sub>P</sub>	M <sub>Y</sub>	Block kg	Rail kg/m
CGW15CC	24	4.1	16	47	38	4.5	30	26	39.6	58.2	6	4.25	5	6.5	3.8	3.8	M5	15	16.2	7.5	5.9	4.5	60	20	M4x17	14.7	19.52	0.19	0.14	0.14	0.14	1.58
CGW20CC	30	4.65	21.5	63	53	5	40	35	52.5	74.9	6	5.5	6.5	7.7	3.7	3.5	M6	20	20.55	9.5	8.5	6	60	20	M5x19	23.7	30.51	0.37	0.28	0.28	0.36	2.48
CGW20HC	30	4.65	21.5	63	53	5	40	35	68.5	90.9	6	5.5	6.5	7.7	3.7	3.5	M6	20	20.55	9.5	8.5	6	60	20		28.6	39.9	0.48	0.48	0.48	0.47	2.48
CGW25CC	36	6.1	23.5	70	57	6.5	45	40	61	84	13	5	7	9.3	6	5.5	M8	23	24.25	11	9	7	60	20	M6x22	34.96	43.94	0.6	0.49	0.49	0.53	3.38
CGW25HC	36	6.1	23.5	70	57	6.5	45	40	78.4	101.4	13	5	7	9.3	6	5.5	M8	23	24.25	11	9	7	60	20		40.5	54.08	0.74	0.73	0.73	0.68	3.38
CGW30CC	42	7	31	90	72	9	52	44	69	97.4	13	8.7	10.5	12	6.7	7	M10	28	28.35	14	12	9	80	20	M8x25	46	55.19	0.95	0.7	0.7	0.9	5.1
CGW30HC	42	7	31	90	72	9	52	44	91.5	119.9	13	8.7	10.5	12	6.7	7	M10	28	28.35	14	12	9	80	20		58.59	78.18	1.35	1.23	1.23	1.19	5.1
CGW35CC	48	7.6	33	100	82	9	62	52	79	111.4	13	7	10.1	13.1	9	7	M10	34	31.85	14	12	9	80	20	M8x28	61.17	79.3	1.73	1.09	1.09	1.37	7.14
CGW35HC	48	7.6	33	100	82	9	62	52	103.4	135.8	13	7	10.1	13.1	9	7	M10	34	31.85	14	12	9	80	20		77.9	112.34	2.46	2.02	2.02	1.79	7.14
CGW45CC	60	9.7	37.5	120	100	10	80	60	97.2	137.6	13	8.7	13.5	15	8.5	8.1	M12	45	39.85	20	17	14	105	22.5	M12x37	98.43	112.66	3.56	2.35	2.35	2.45	11.51
CGW45HC	60	9.7	37.5	120	100	10	80	60	133.6	174	13	8.7	13.5	15	8.5	8.1	M12	45	39.85	20	17	14	105	22.5		125.58	159.6	5.05	4.45	4.45	3	11.51

Note : 1 kgf = 9.81 N

### (5) Dimensions for CGR-T (Rail Mounting from Bottom)

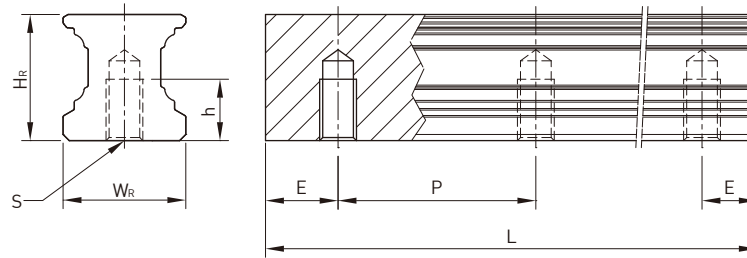

Size	Dimensions of Rail (mm)					
	WR	HR	S	h	P	E
CGR15T	15	16.2	M5X0.8P	8	60	20
CGR20T	20	20.55	M6X1P	10	60	20
CGR25T	23	24.25	M6X1P	12	60	20
CGR30T	28	28.35	M8X1.25P	15	80	20
CGR35T	34	31.85	M8X1.25P	17	80	20
CGR45T	45	39.85	M12X1.75P	24	105	22.5

### (6) Dimension of cover strip and plastic end jig

- plastic end jig (standard)

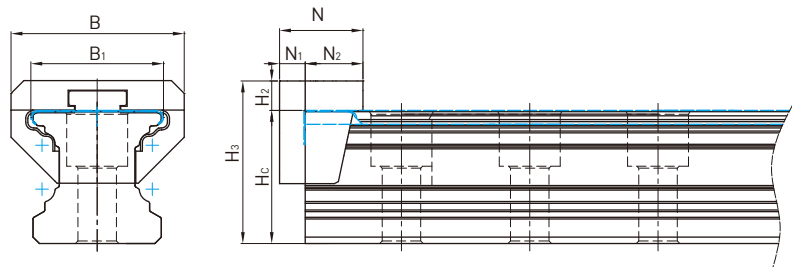

Size	H <sub>3</sub>	H <sub>c</sub> <sup>1</sup>	H <sub>2</sub>	N	N <sub>1</sub>	N <sub>2</sub>	B	B <sub>1</sub>
CG 15	20.8	16.4	4.4	13.0	3.7	9.3	20.0	15.8
CG 20	25.65	20.75	4.9	13.0	4.0	9.0	27.0	20.7
CG 25	29.55	24.45	5.1	15.0	4.2	10.8	31.5	23.9
CG 30	35.45	28.55	6.9	21.0	6.0	15.0	40.0	28.9
CG 35	40.75	32.05	8.7	21.5	6.2	15.3	46.0	34.8
CG 45	48.3	40.05	8.25	22.0	6.2	15.8	51.6	45.6

Note : 1. Dimension H<sub>c</sub> with cover strip

- Metal end jig (optional)

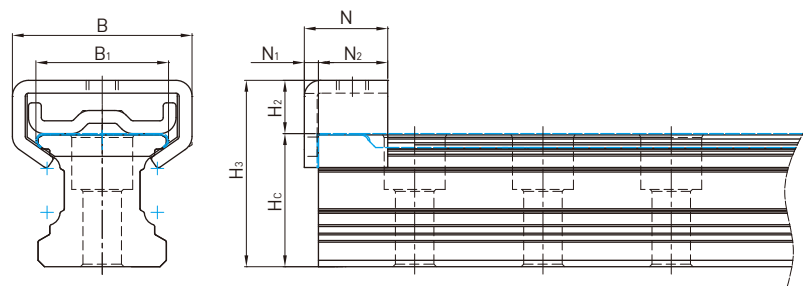

Size	H <sub>3</sub>	H <sub>c</sub> <sup>1</sup>	H <sub>2</sub>	N	N <sub>1</sub>	N <sub>2</sub>	B	B <sub>1</sub>
CG 15	20.09	16.4	3.69	15.0	2.2	12.8	21.0	15.8
CG 20	29.05	20.75	8.3	13.0	2.2	10.8	28.0	20.7
CG 25	34.42	24.45	9.97	15.0	2.2	12.8	30.6	23.9
CG 30	37.80	28.55	9.25	12.0	2.2	9.8	34.0	28.9
CG 35	43.2	32.05	11.15	18.0	2.2	15.8	35.4	34.8
CG 45	52.66	40.05	12.61	18.0	2.2	15.8	53.6	45.6

Note : 1. Dimension H<sub>c</sub> with cover strip